

REV.	DESCRIPTION	DATE	APPROVED
------	-------------	------	----------

NOTES:

1. DEBUR ALL SHARP EDGES
2. ADDITIONAL MATERIAL MAY BE LEFT FOR POST WELDING MACHINING.

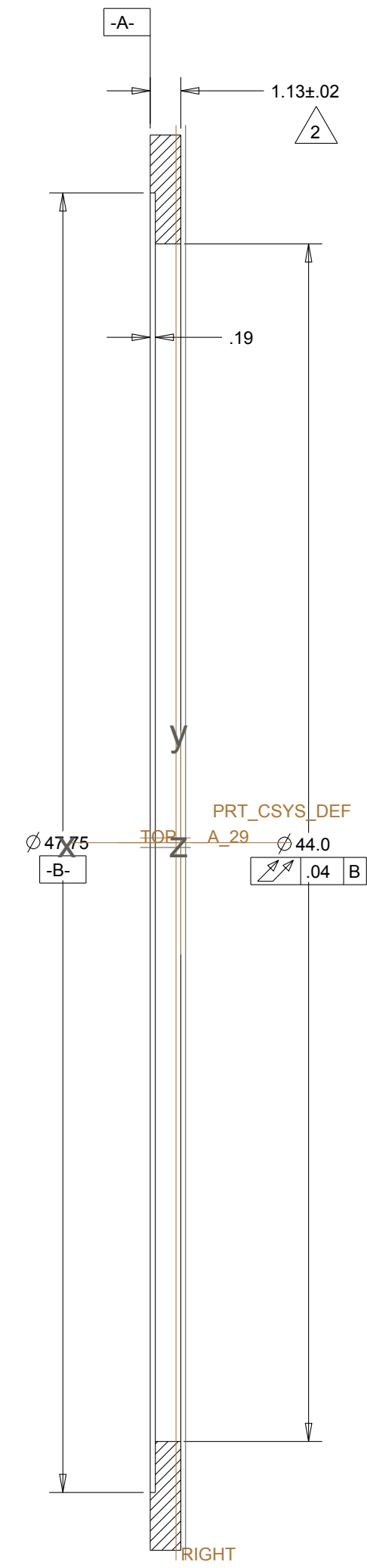
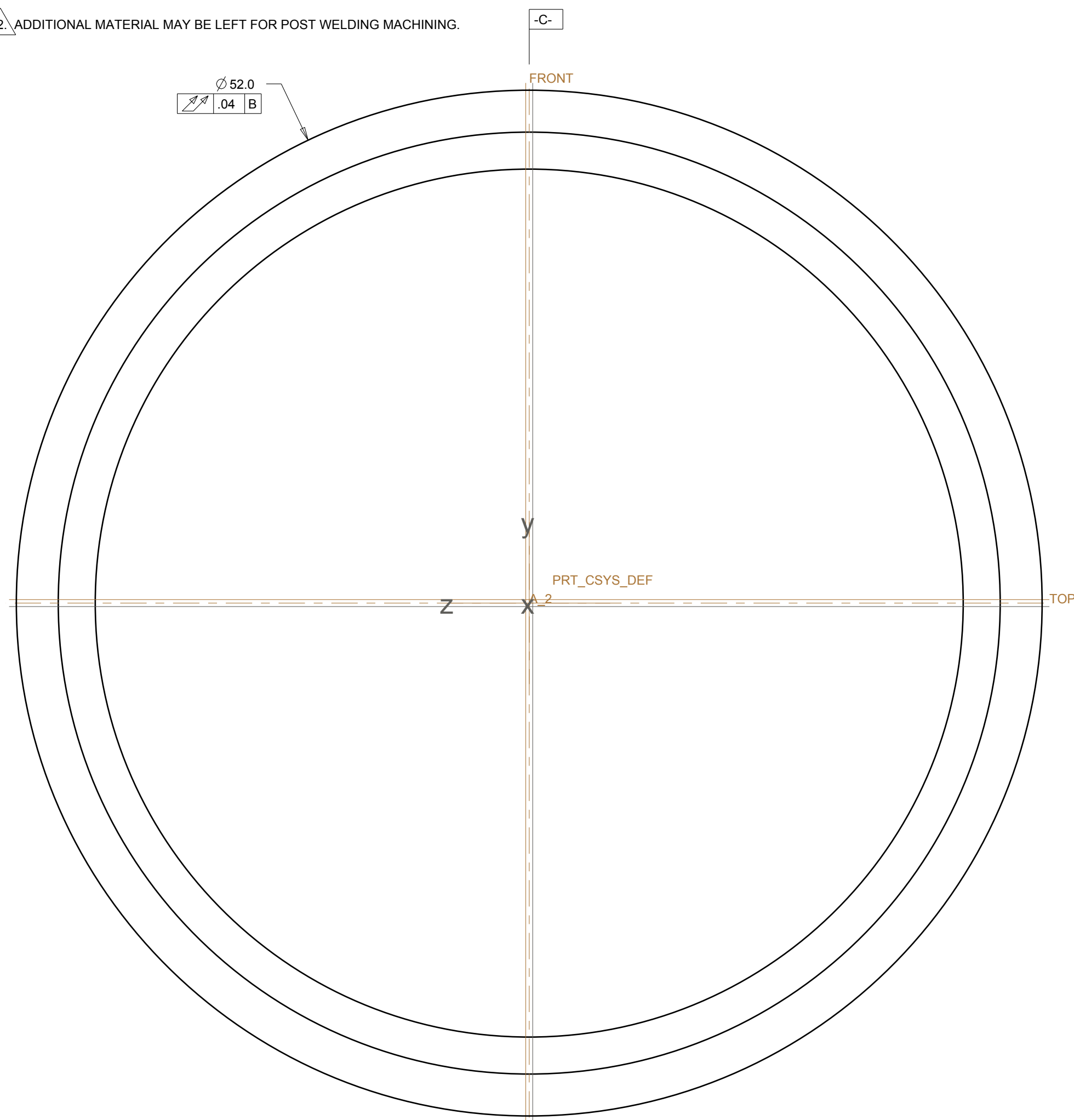

SECTION A-A

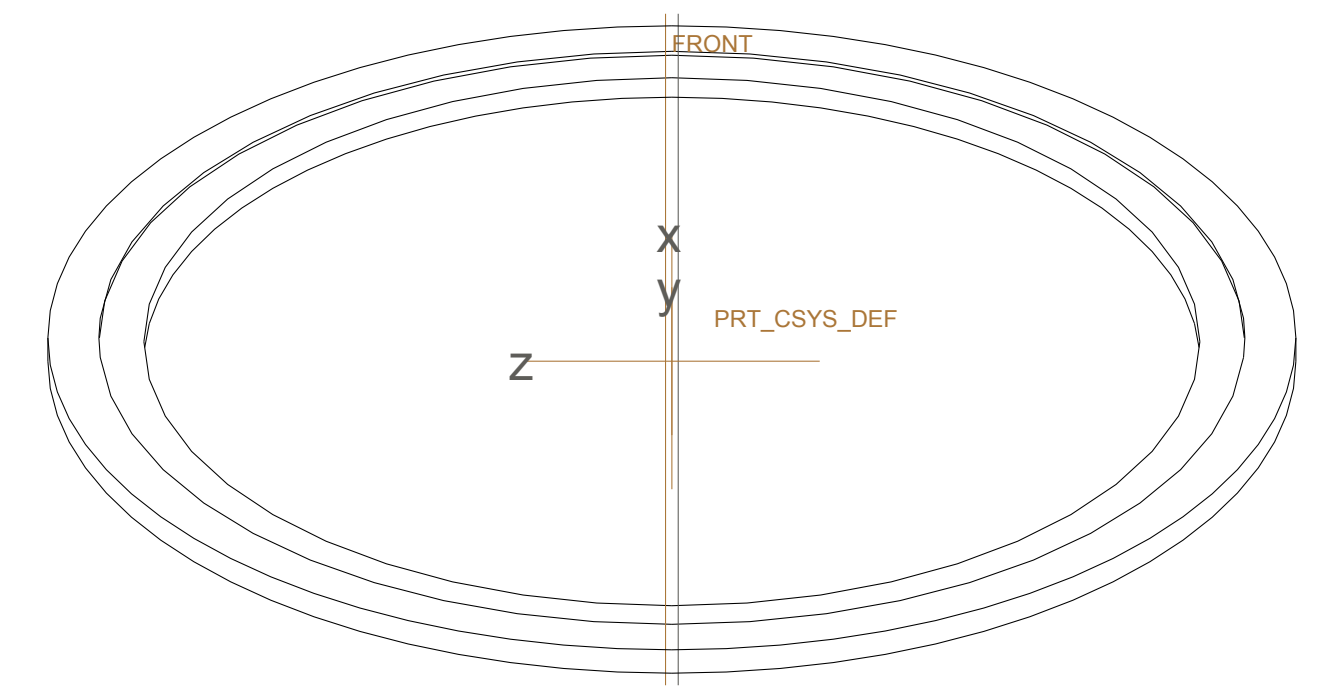

SCALE 1/8

		4-STAR			
		A. HARDING	01/05/07	Front Cone Flange	
		S. SMEE	C	4-STAR-F-0001	-
6061-T651			3/16		1 OF 1