

REV.	DESCRIPTION	DATE	APPROVED
------	-------------	------	----------

NOTES:

- 1. DEBUR ALL SHARP EDGES
- 2. ROLL & SEAM WELD
- 3. FIT TO 4-STAR-F-0001
- 4. FIT TO 4-STAR-F-0003

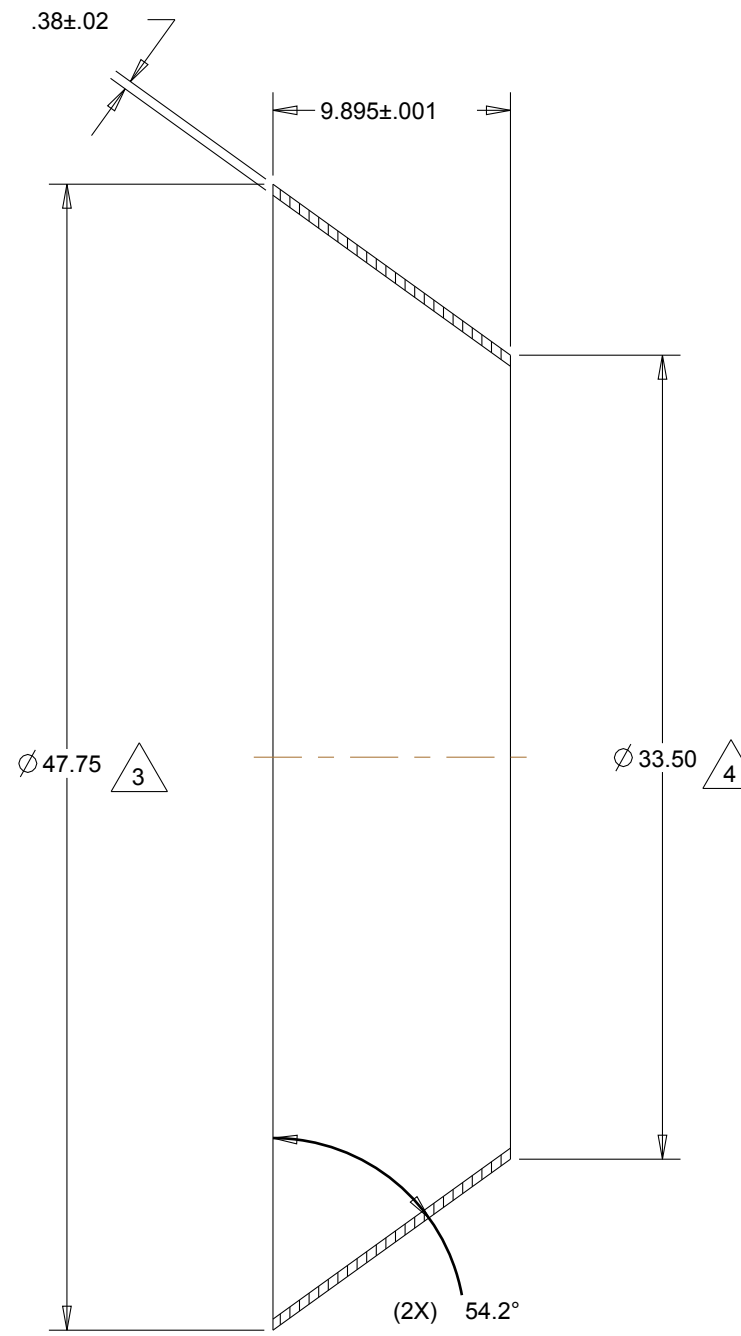
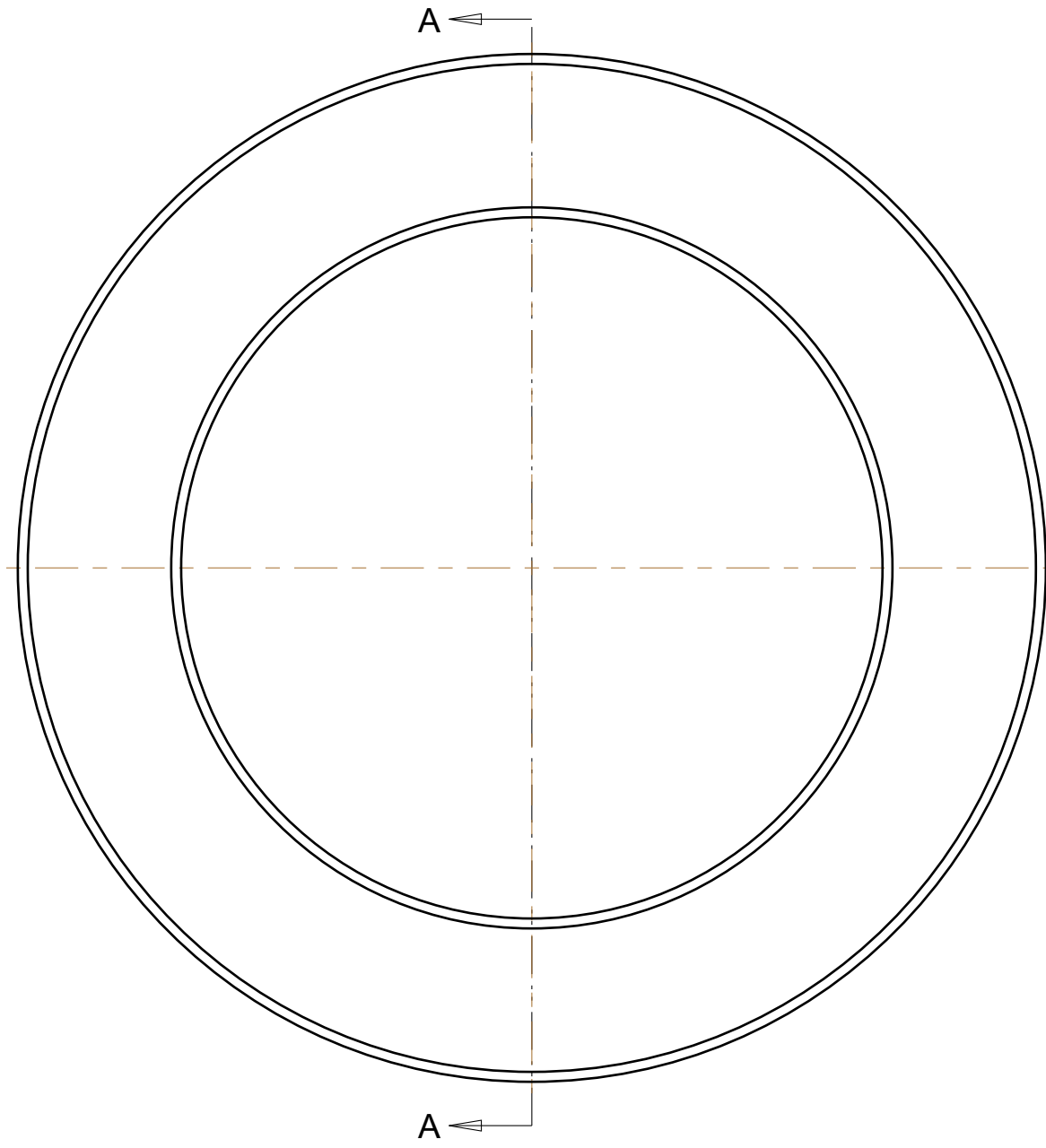

SECTION A-A

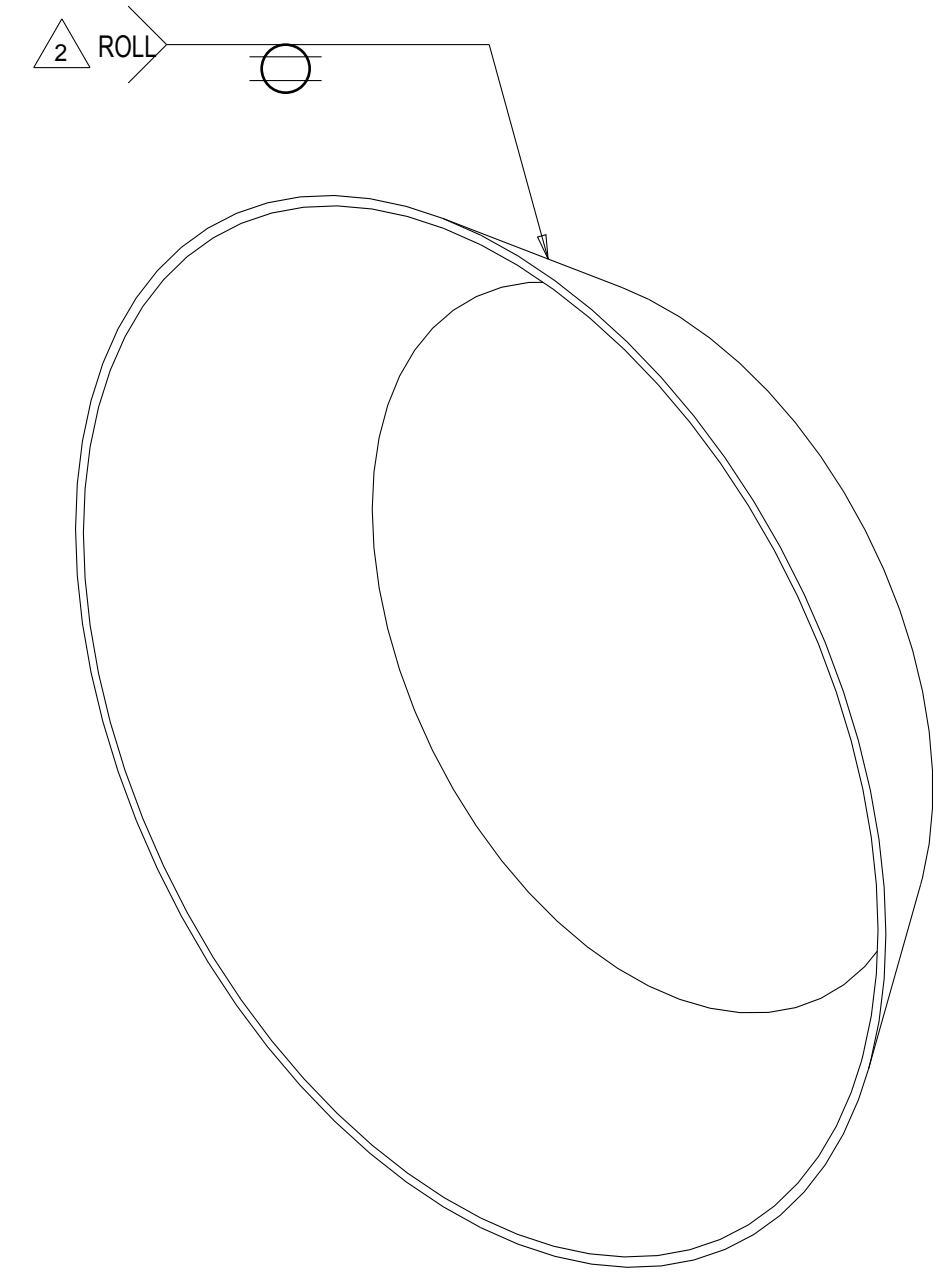

	4-STAR			
	A. HARDING	01/05/07	Cone	
6061-T651	S. SMEE	C	4-STAR-F-0002	-
		1/8	1 OF 1	