

REV.	DESCRIPTION	DATE	APPROVAL
------	-------------	------	----------

NOTES:

1. DEBUR ALL SHARP EDGES
2. MODIFY COMMERCIAL BI-BRAZE TRANSITION AS SHOWN

3 WELD PREP

4 MACHINE FOR SLIP FIT TO 4-STAR-F-0102. ADJUST NOMINAL DIAMETER BASED ON TUBING OD.

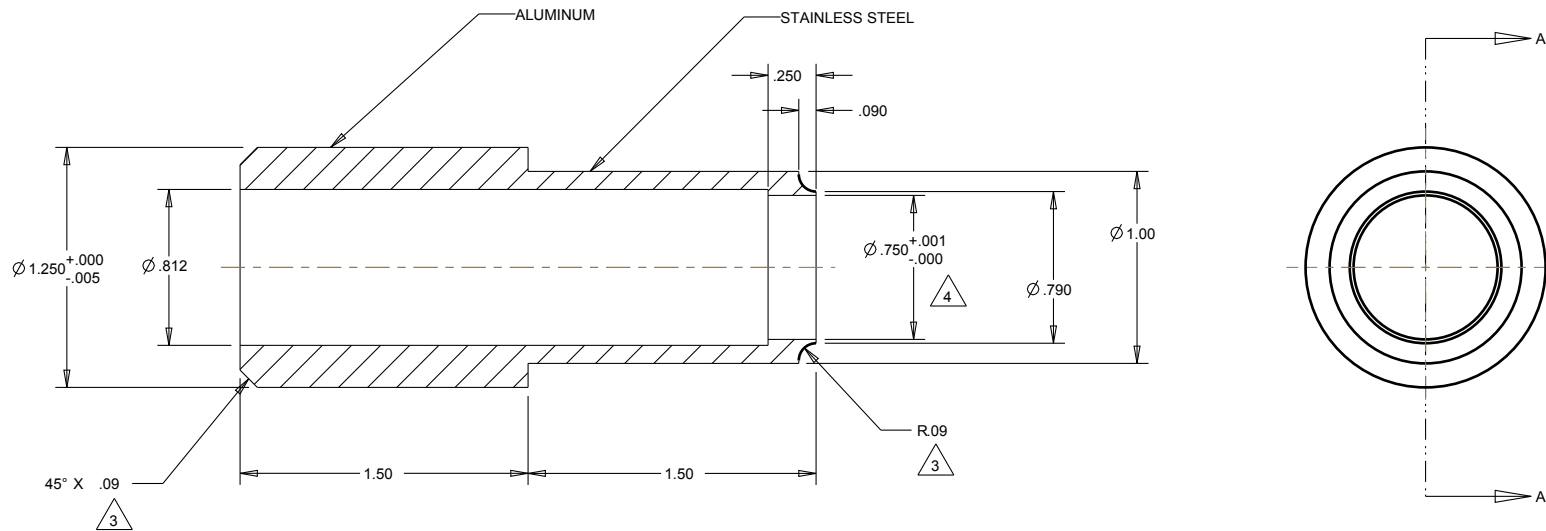

SECTION A-A

	<b>4-STAR</b>			
	SCHARFSTEIN	04/21/08	Bi-Braze SS-Al Transition	
ALUMINUM & STAINLESS STEEL	S. SMEE		A	4-STAR-F-0088
	NONE		1/1	1 OF 1