

NOTES:

1. DEBUR ALL SHARP EDGES.
2. CHEMICAL FILM AS PER MIL-C-5541C CLASS3 GOLD.
3. ANODIZE AS PER MIL-A-8625 TYPE II CLASS 2 BLACK WITH PTFE. MASK PAINTED SURFACES.
4. APPLY AEROGLAZE 9929 EPOXY PRIMER FOLLOWED BY AEROGLAZE Z306 PAINT TO INDICATED SUFACES. THE TOTAL BUILDUP IS NOT TO EXCEED .0015". MASK ALL THROUGH HOLES AND THREADED HOLES.
5. DIMENSIONS DO NOT INCLUDE PLATING BUILD UP OF .0002"-.0003" DIMENSIONAL CHANGE RESULTING FROM PAINT BUILDUP IS PERMISSIBLE.
6. SOURCE FOR PART PLATING/PAINTING:

Alexandria Metal Finishers
 9418 Gunston Cove Road
 Lorton, Virginia 22079
 Ph - (703) 643-1636
 Fax - (703) 690-6731

REV.	DESCRIPTION	DATE	APPROVED
A	MODIFIED ANODIZE SPEC., (2X) ADDED R.015, SEE DETAIL "B"	2/07/08	S. SMEE
B	(2X) ADDED #8-32 TAPPED THRU HOLES $\varnothing 16.485$ WAS $\varnothing 16.498$ (ZONE B-3)	6/2/08	S. SMEE
C	MODIFIED PAINT SURFACE FINISH ON FRONT FACE, ZONE C-3	6/23/08	S. SMEE

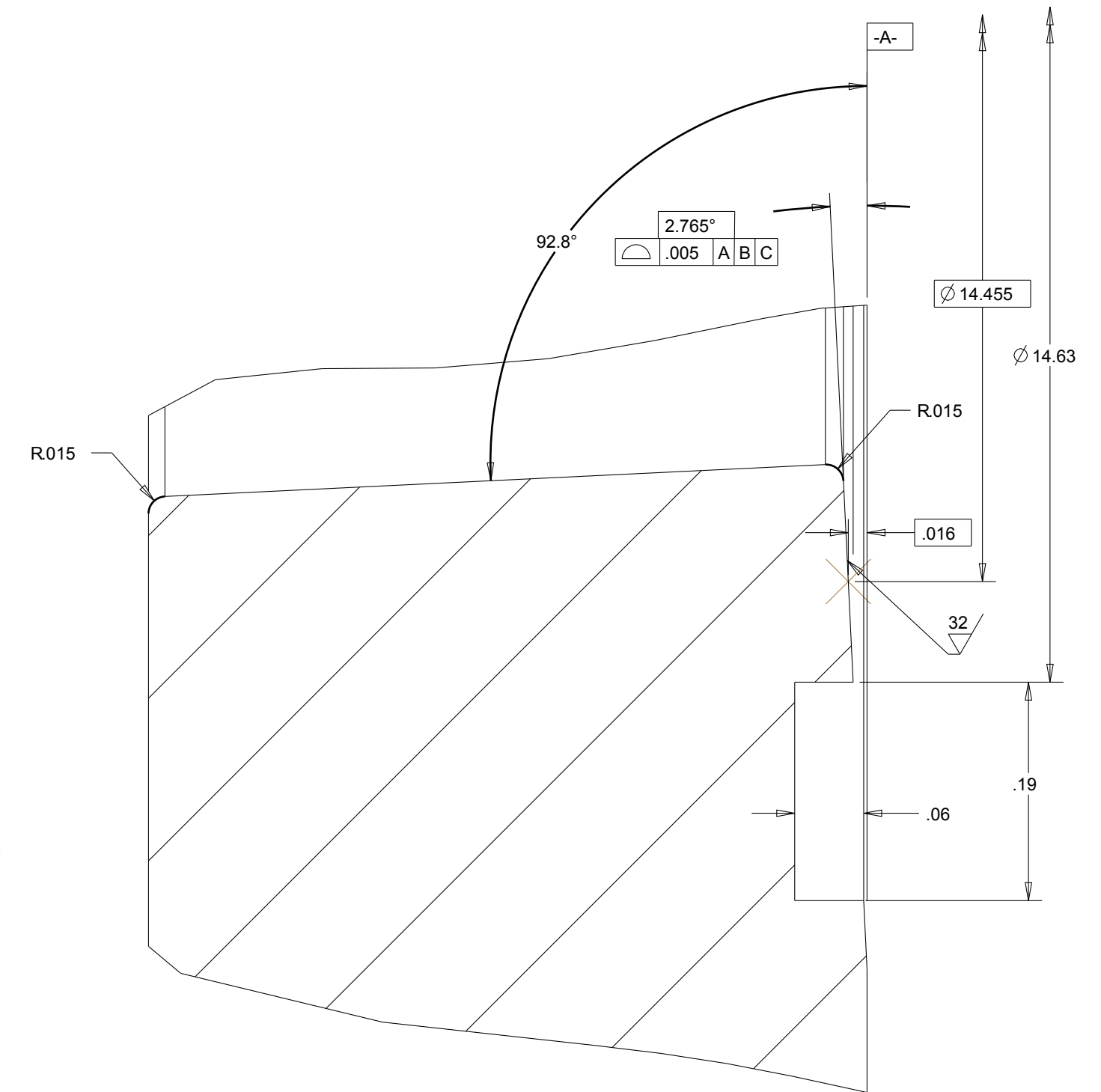
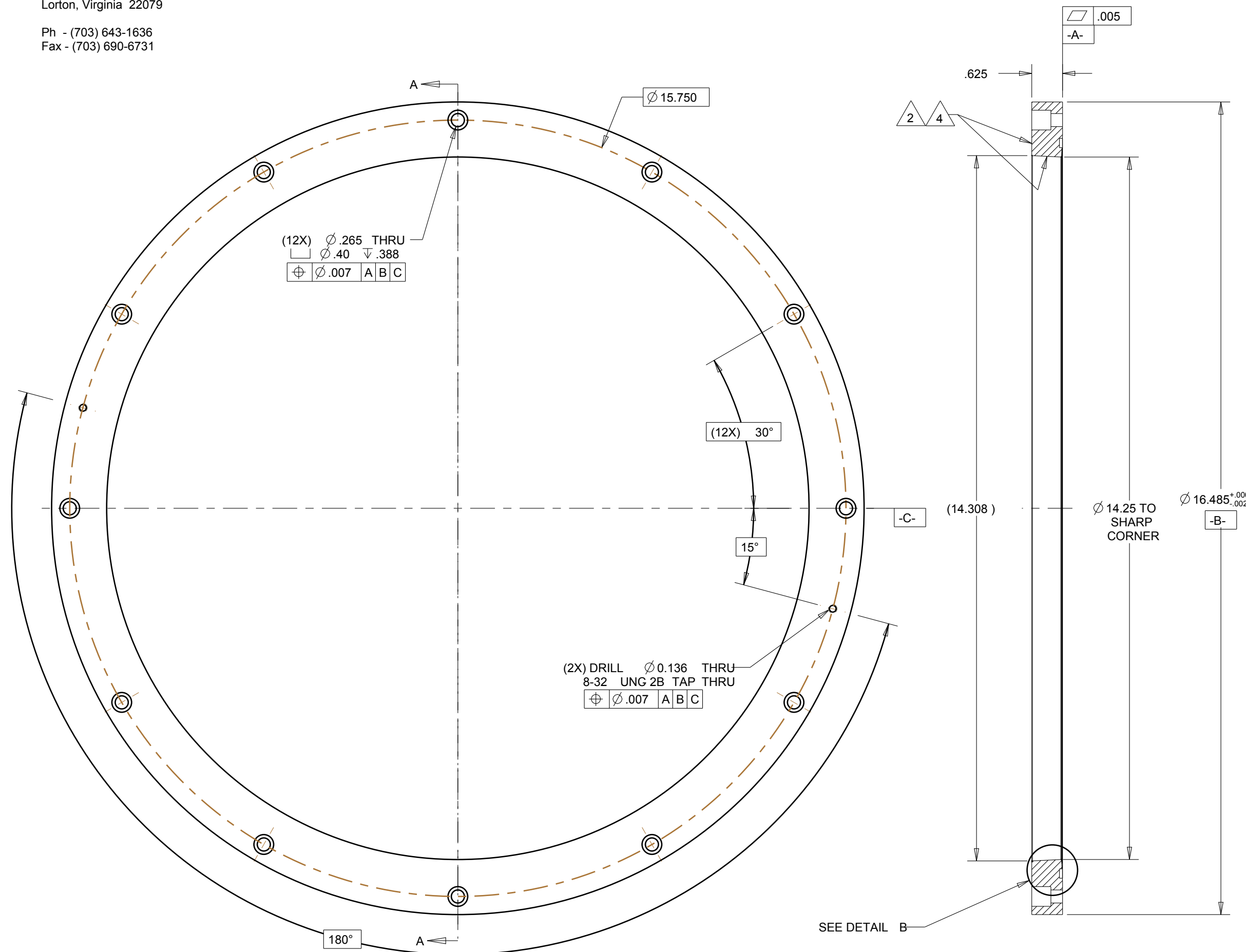

		4-STAR			
		SCHARFSTEIN	11/14/07	L1 RETAINER	
		S. SMEE	C	4-STAR-F-0164	C
6061-T6	SEE NOTES	1/2		1 OF 1	