

NOTES:

1. DEBUR ALL SHARP EDGES.
2. NOMINAL DIMENSIONS MAY VARY BY ± .001. TOLERANCE DEFINES CONSISTANCY FROM FEATURE TO FEATURE.
3. ANODIZE INDICATED SURFACES AS PER MIL-A-8625 TYPE II CLASS 2 BLACK WITH PTFE. ALL THREADED HOLES ARE TO BE MASKED.
4. MASK THESE FEATURES AND/OR SURFACES FROM PLATING.
5. DIMENSIONS DO NOT INCLUDE PLATING BUILD UP OF .0002"-.0003"
6. SOURCE FOR PART PLATING:

Alexandria Metal Finishers
 9418 Gunston Cove Road
 Lorton, Virginia 22079
 Ph - (703) 643-1636
 Fax - (703) 690-6731

REV	DESCRIPTION	DATE	APPROVED
A	ELIMINATED ELECTROPOLISH SPEC, MODIFIED ANODIZE SPEC.	1/17/08	S. SMEE
B	ADDED SLOT, ZONE D-3	6/23/08	S. SMEE

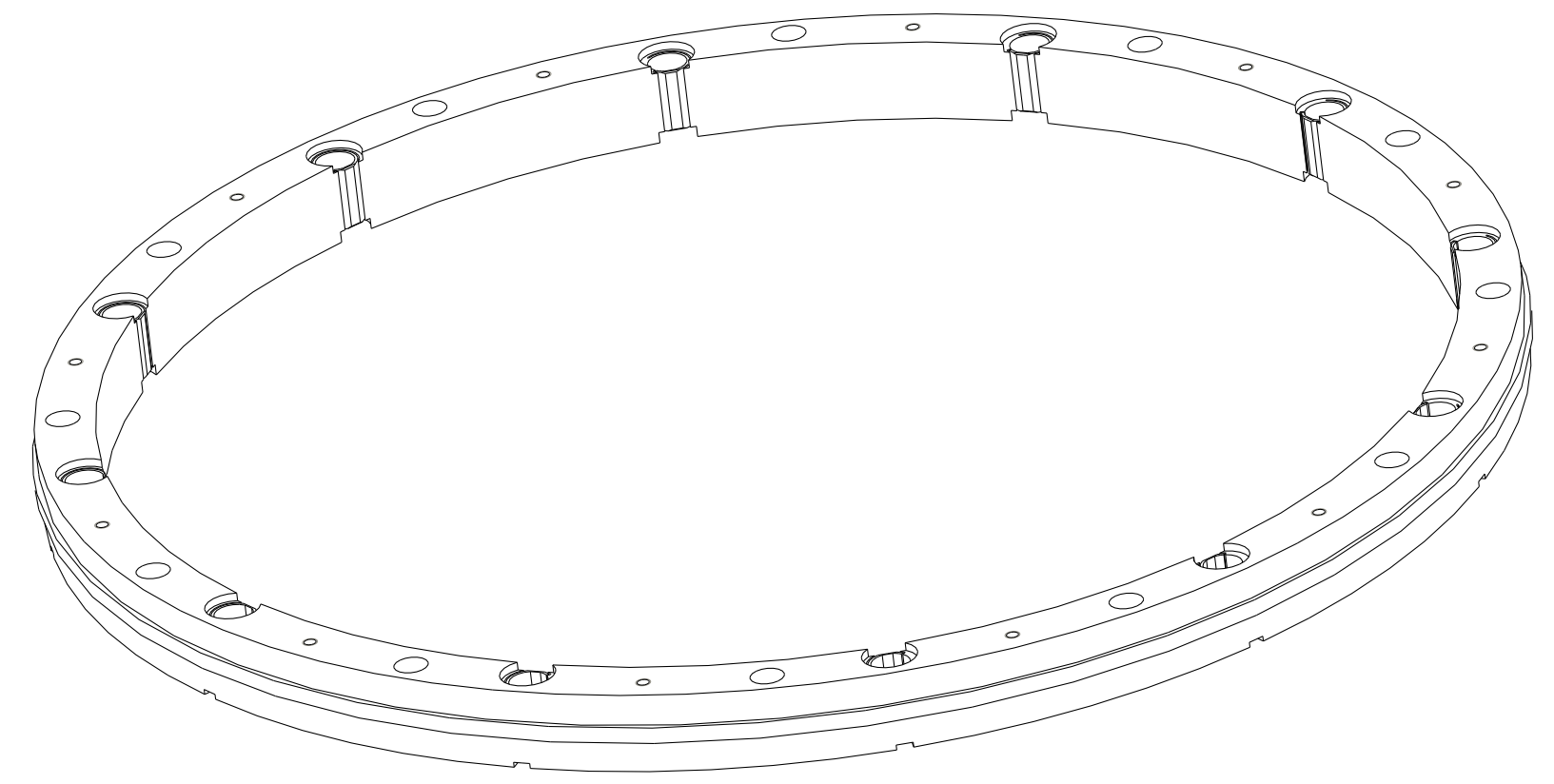
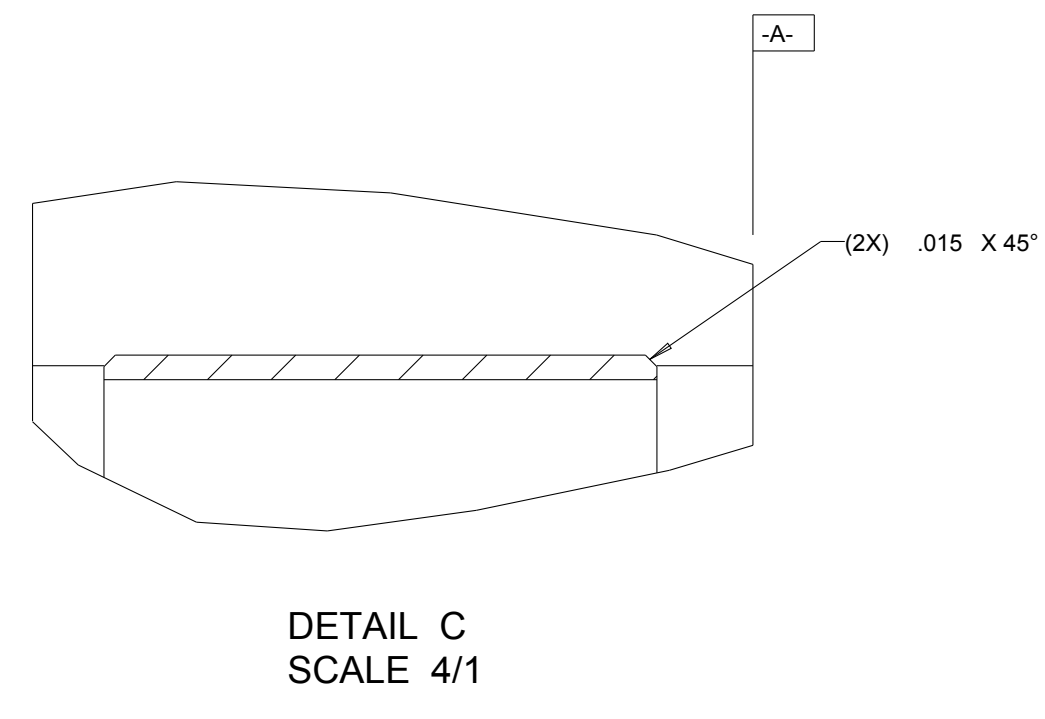
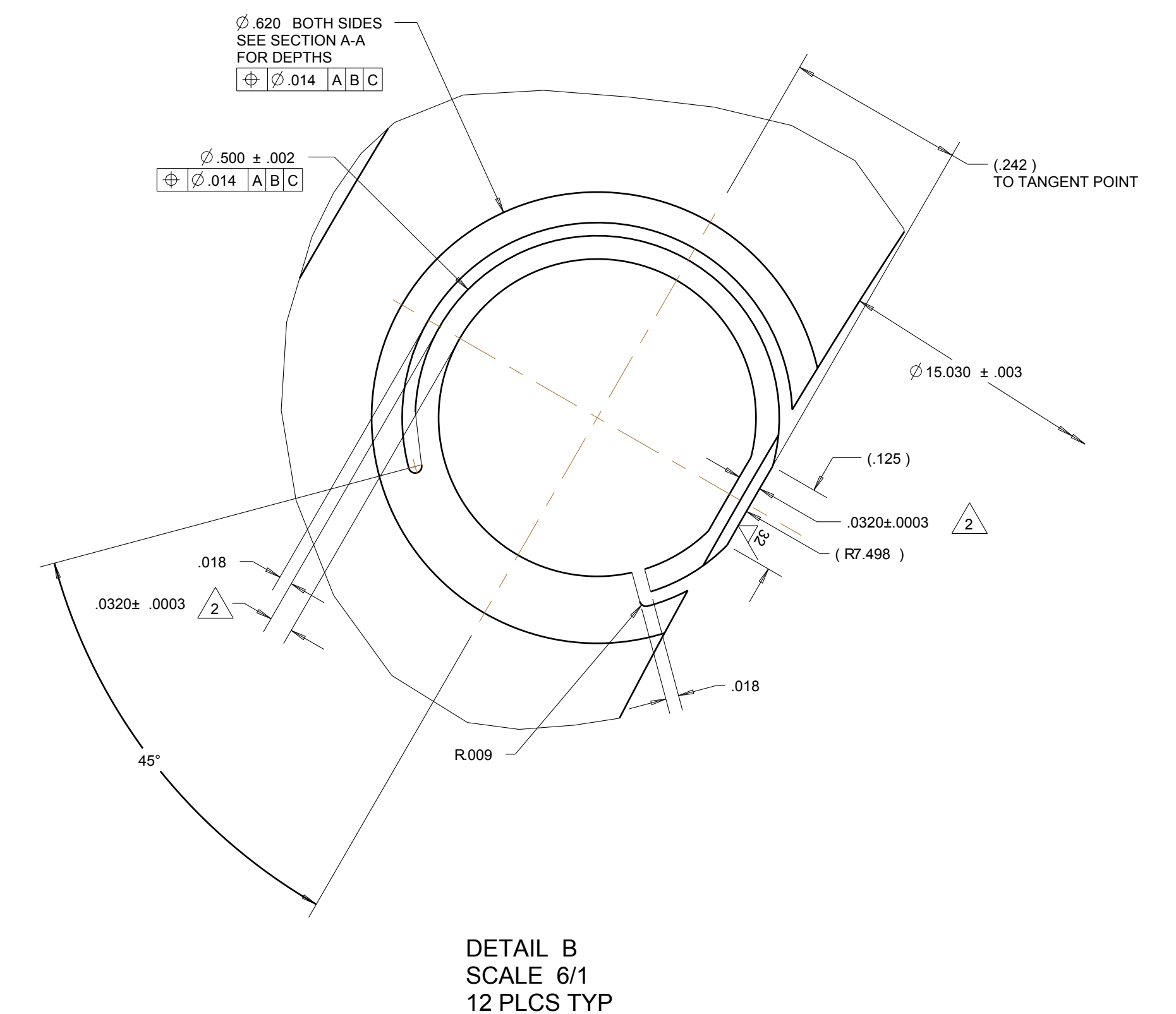
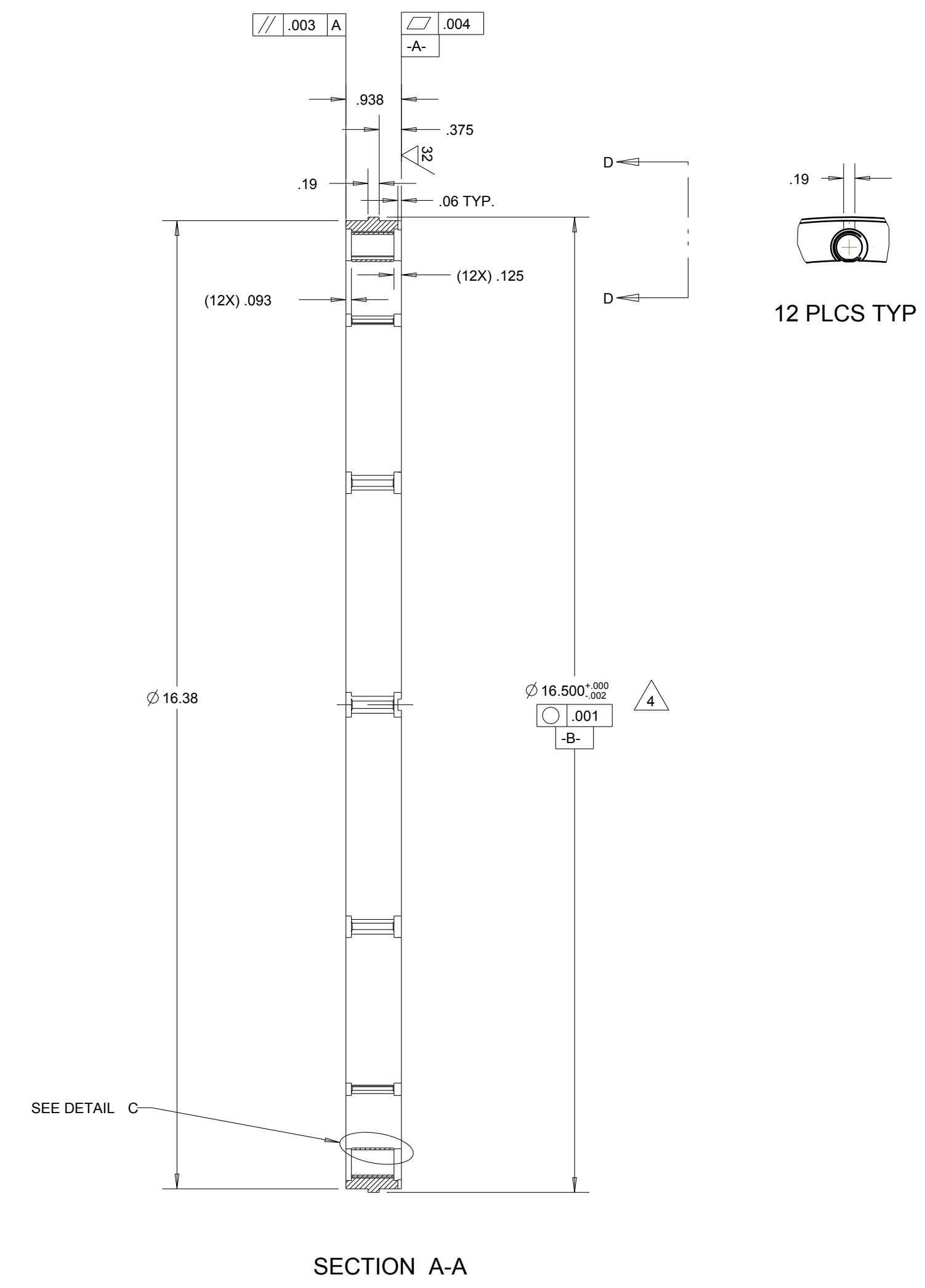
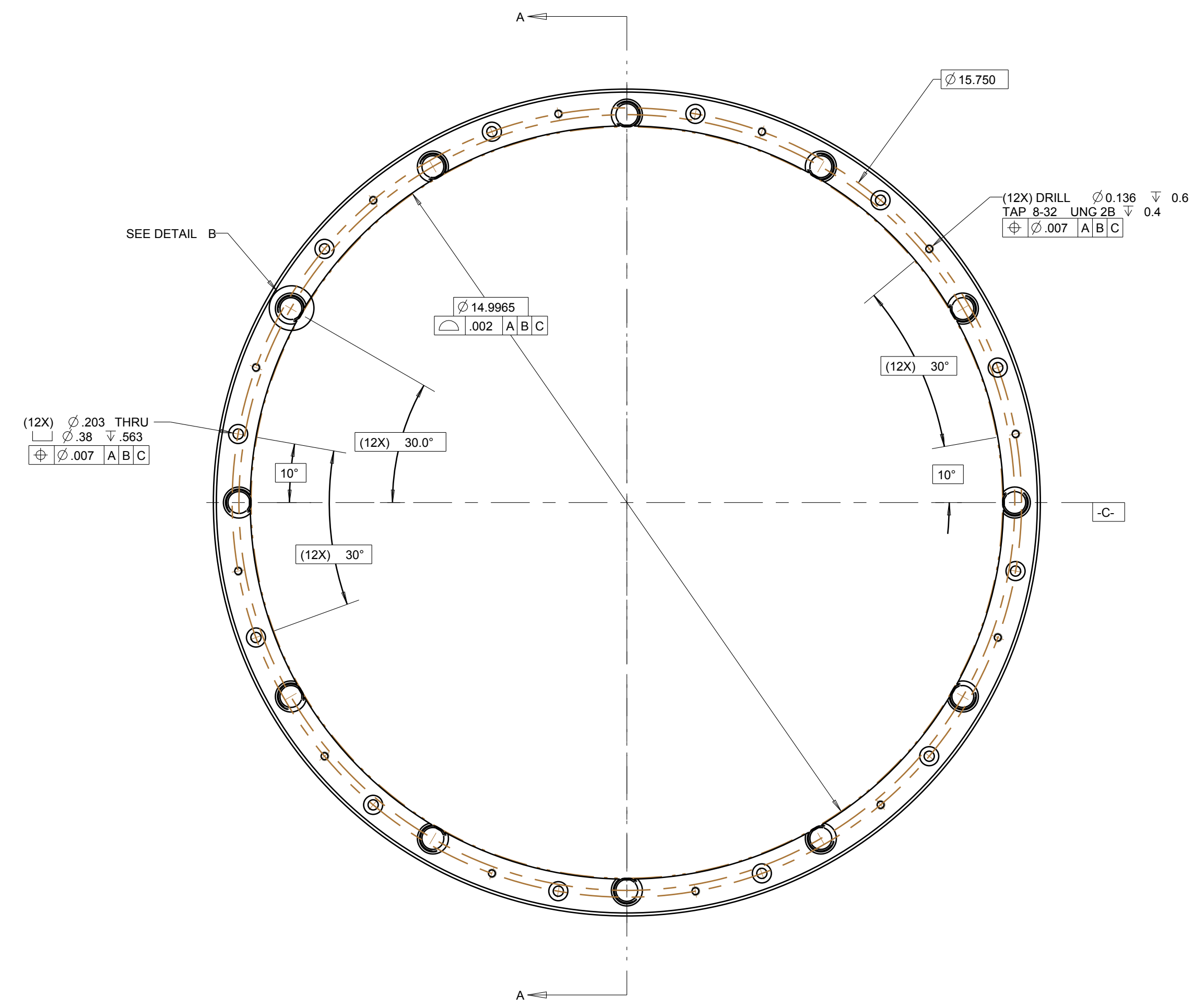

		4-STAR			
		SCHARFSTEIN	11/14/07	L2 Cell	
		S. SMEE	D	4-STAR-F-0165	B
7075-T6	SEE NOTES	1/2		1 OF 1	