

NOTES:

1. DEBUR ALL SHARP EDGES.
2. CHEMICAL FILM AS PER MIL-C-5541C CLASS3 GOLD.
3. ANODIZE AS PER MIL-A-8625E TYPE II CLASS 2 BLACK WITH PTFE. MASK PAINTED SURFACES.
4. APPLY AEROGLAZE 9929 EPOXY PRIMER FOLLOWED BY AEROGLAZE Z306 PAINT TO INDICATED SUFACES. THE TOTAL BUILDUP IS NOT TO EXCEED .0015". MASK ALL THROUGH HOLES AND THREADED HOLES.
5. DIMENSIONS DO NOT INCLUDE PLATING BUILD UP OF .0002"-.0003". DIMENSIONAL CHANGE RESULTING FROM PAINT BUILDUP IS PERMISSIBLE.
6. SOURCE FOR PART PLATING/PAINTING:

Alexandria Metal Finishers
 9418 Gunston Cove Road
 Lorton, Virginia 22079
 Ph - (703) 643-1636
 Fax - (703) 690-6731

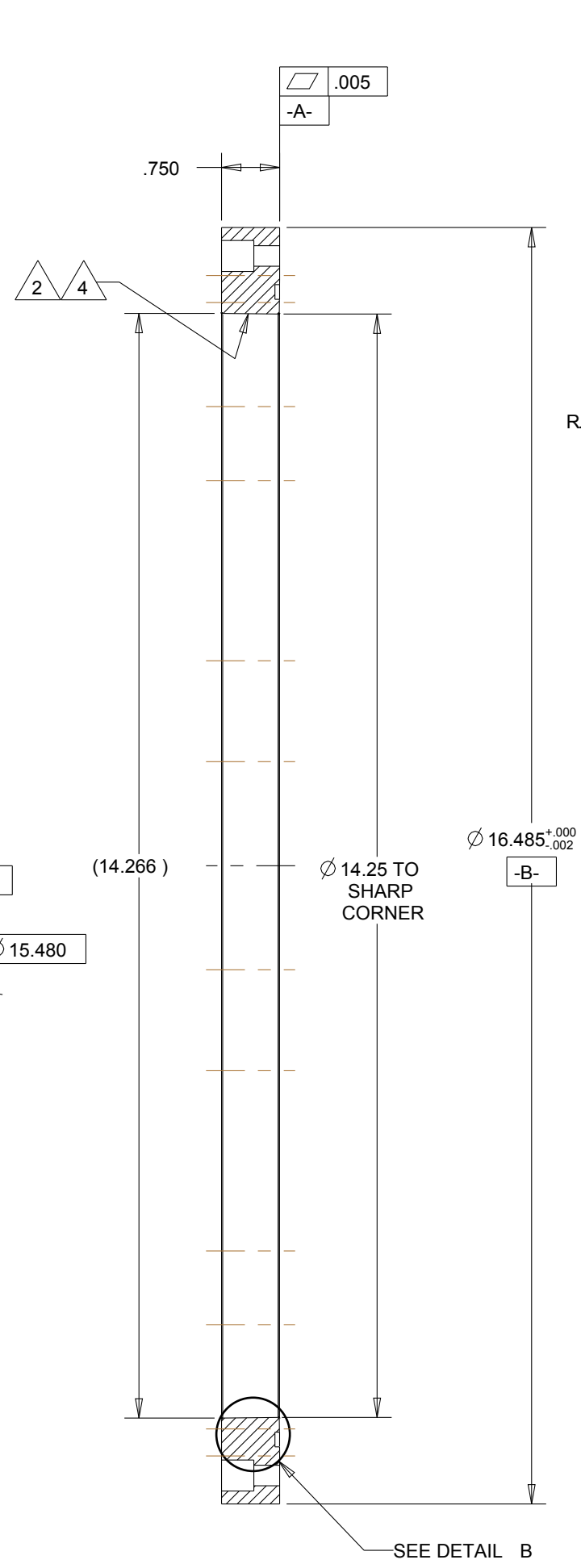
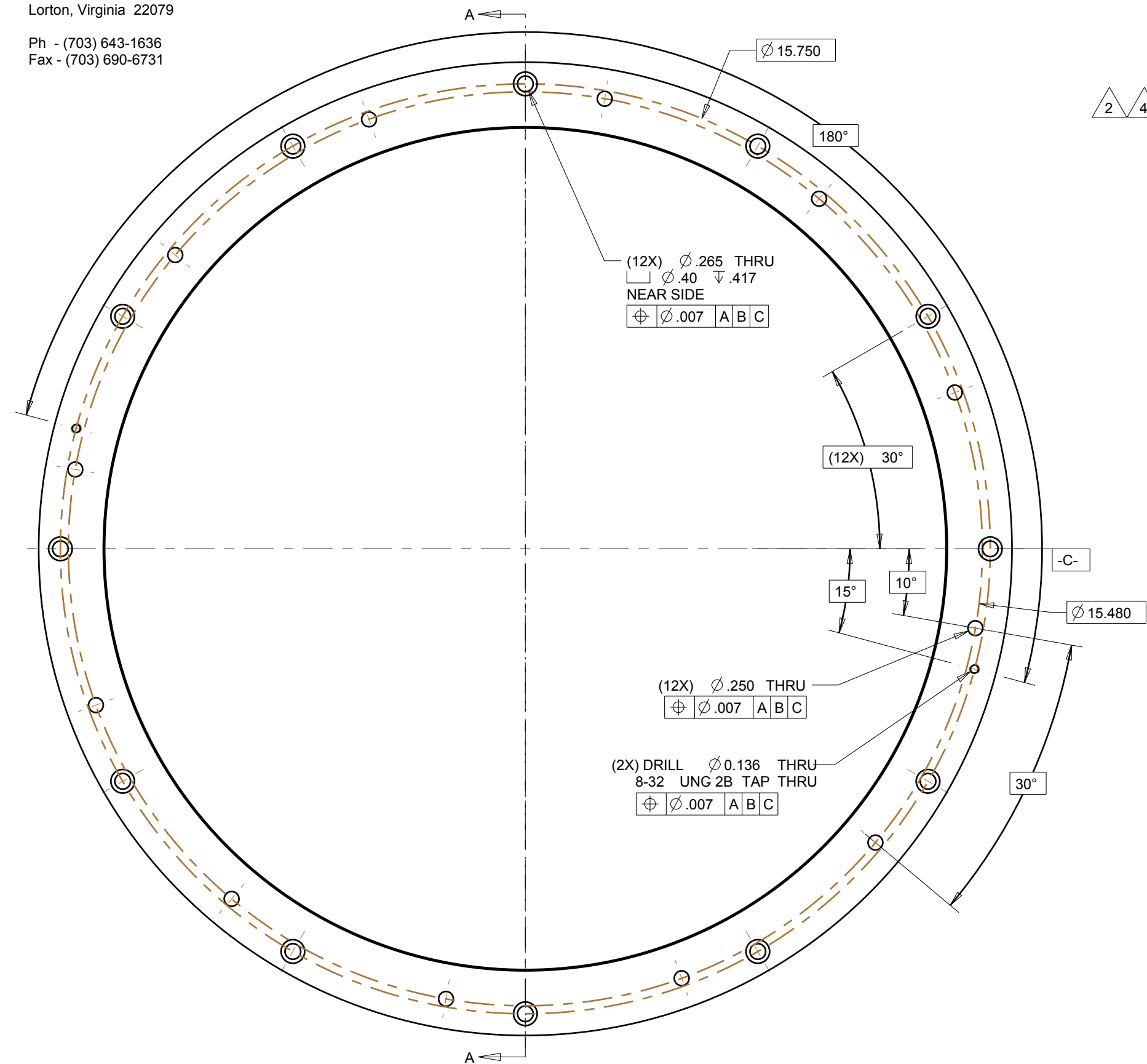

SECTION A-A

REV.	DESCRIPTION	DATE	APPROVED
A	MODIFIED ANODIZE SPEC., (2X) ADDED R.015, SEE DETAIL "B"	2/07/08	S. SMEE
B	(2X) ADDED #8-32 TAPPED THRU HOLES \varnothing 16.485 WAS \varnothing 16.498 (ZONE B-2) ADDED \varnothing .250 THRU HOLES	6/2/08	S. SMEE

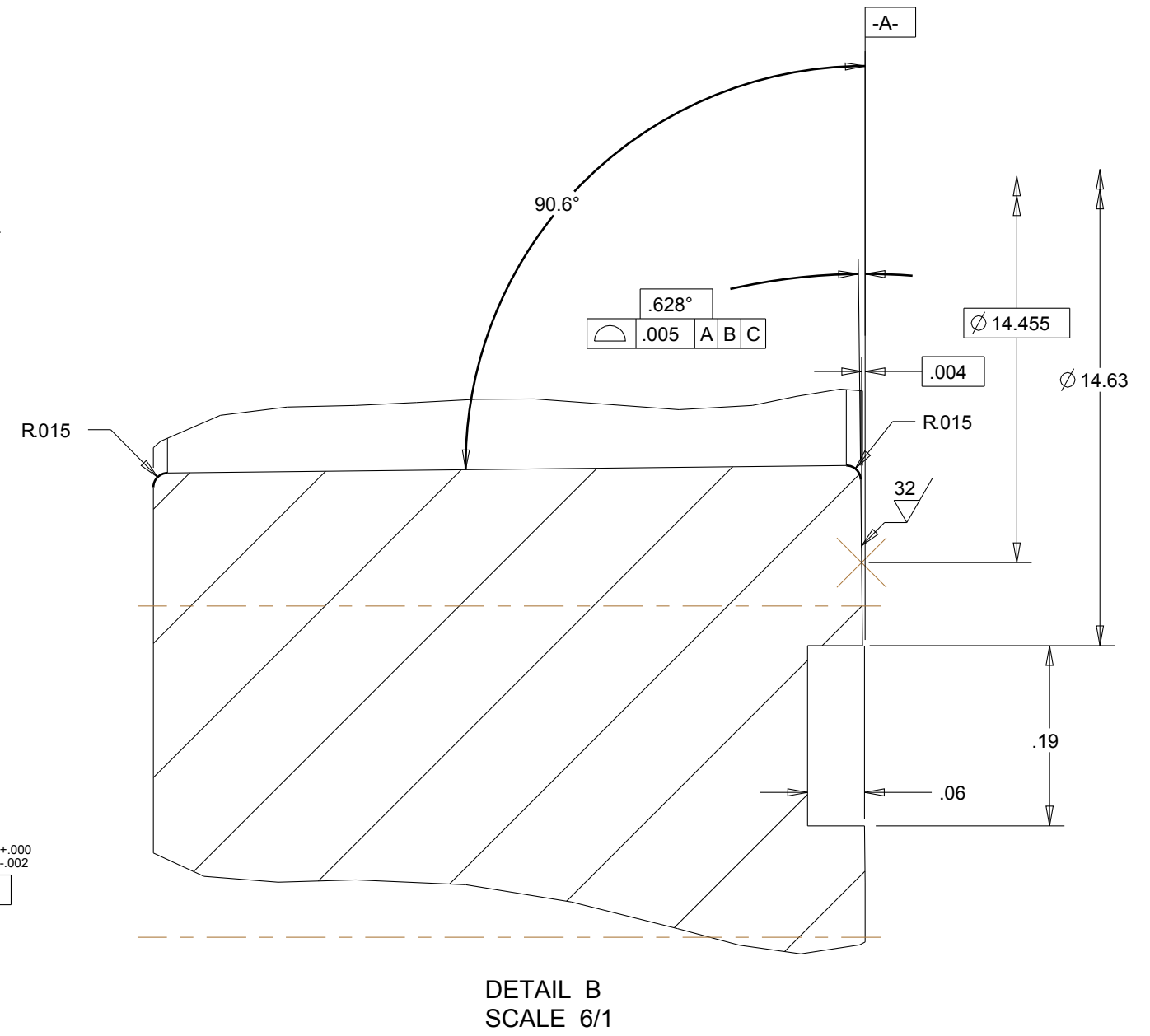

		4-STAR			
		SCHARFSTEIN	11/14/07	L2 RETAINER	
		S. SMEE	C	4-STAR-F-0166	B
6061-T6	SEE NOTES	1/2		1 OF 1	