

SCALE 10 : 1

REFERENCE DIMENSIONS

REV	CHANGES	DATE	BY	MATERIAL:	UNLESS OTHERWISE SPECIFIED: DIMENSIONS ARE IN INCHES BRAKE EDGES / REMOVE BURRS	**** FourStar	NEXT ASSY	USED ON	THE OBSERVATORIES	
				FINISH:	TOLERANCES:				CARNegie INSTITUTION OF WASHINGTON	
				SCALE:	X.X± 0.1 ANGLES:0.5° X.XX± 0.03 FRACTIONS:± 1/16 X.XXX± 0.010	Designer: GLS	01/23/06		813 SANTA BARBARA STREET PASADENA, CA. 91101-1232	
				As Noted	DO NOT SCALE DRAWING	Drawn: Koch	01/23/06	Drawings Printed on:	LGA_CLAMP_PRESSINNUT	DWG NO. PRESSINNUT
										REV. SHT 1 OF 1

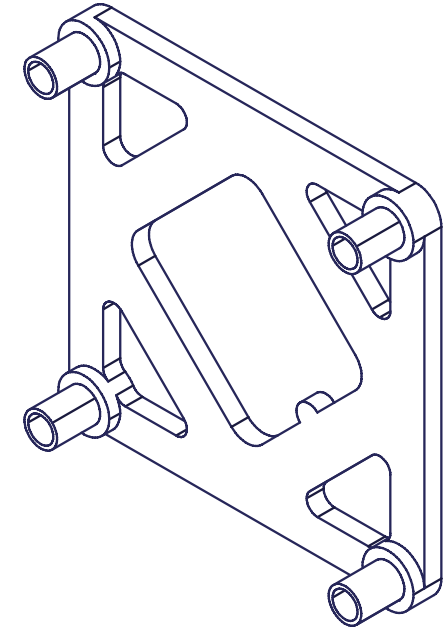
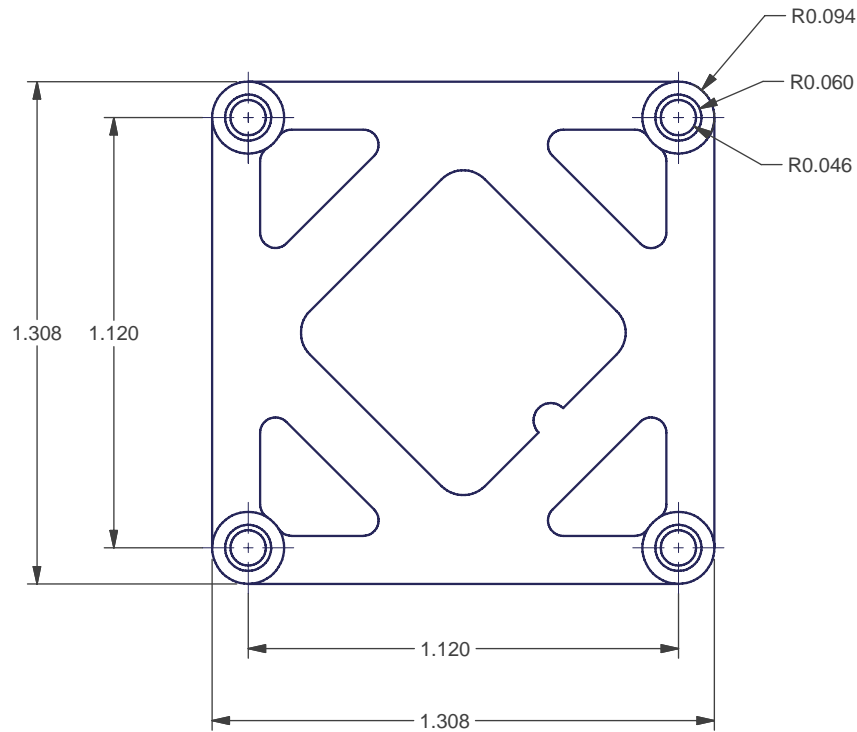
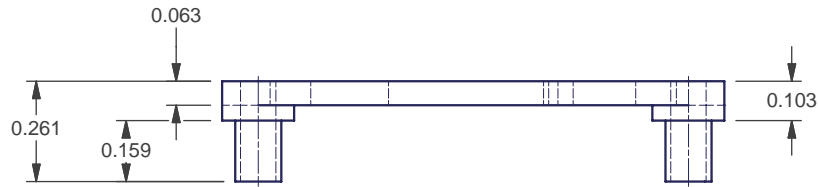

SCALE 2 : 1

REFERENCE DIMENSIONS

REV	CHANGES	DATE	BY	MATERIAL:	UNLESS OTHERWISE SPECIFIED: DIMENSIONS ARE IN INCHES BRAKE EDGES / REMOVE BURRS TOLERANCES: X.X± 0.1 ANGLES:0.5° X.XX± 0.03 FRACTIONS:± 1/16 X.XXX± 0.010 DO NOT SCALE DRAWING	**** FourStar	NEXT ASSY	USED ON	THE OBSERVATORIES CARNEGIE INSTITUTION OF WASHINGTON 813 SANTA BARBARA STREET PASADENA, CA. 91101-1232	DWG NO.	REV.		
				FINISH:			APPLICATION				LGA_CLAMP2	LGA_CLAMP2	SHT 1 OF 1
				SCALE:			Designer: GLS	01/23/06					
				As Noted			Drawn: Koch	01/23/06	Drawings Printed on:				

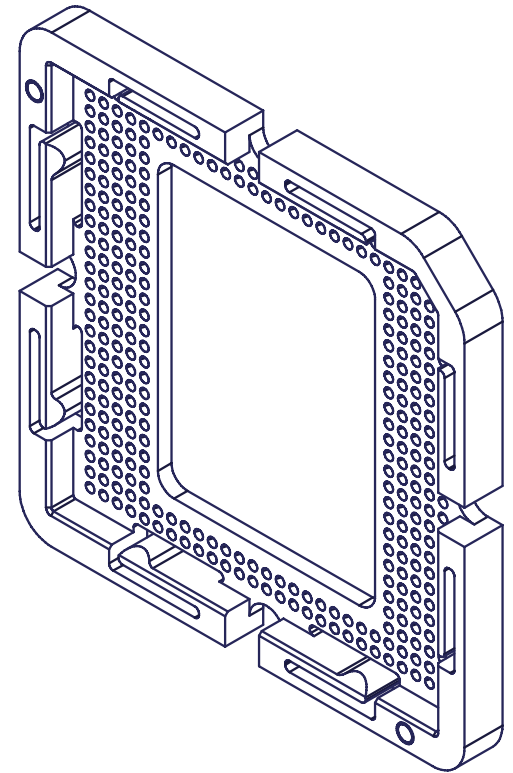
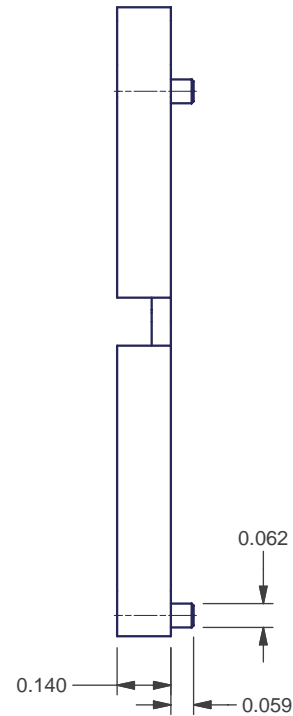
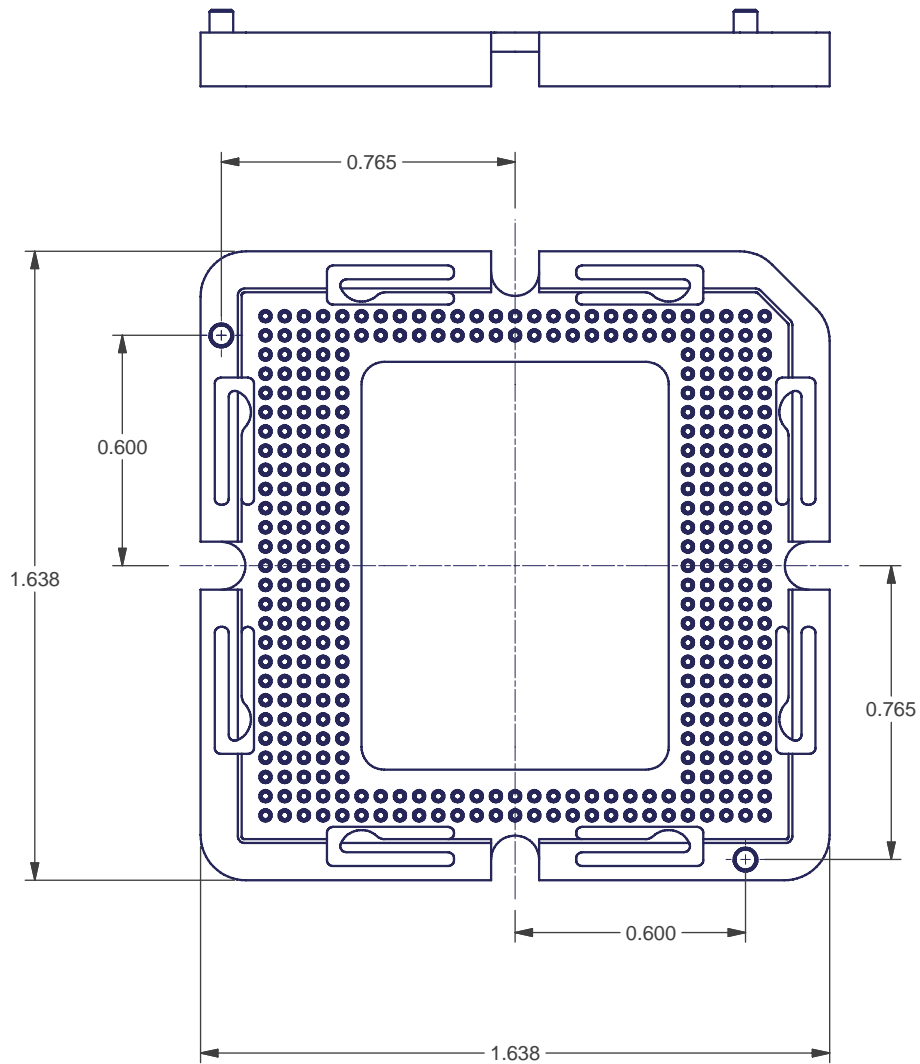

SCALE 2 : 1

REFERENCE DIMENSIONS

REV	CHANGES	DATE	BY	MATERIAL:	UNLESS OTHERWISE SPECIFIED: DIMENSIONS ARE IN INCHES BRAKE EDGES / REMOVE BURRS TOLERANCES: X.X±0.1 ANGLES:0.5° X.XX±0.03 FRACTIONS:± 1/16 X.XXX±0.010 DO NOT SCALE DRAWING	**** FourStar	NEXT ASSY	USED ON	THE OBSERVATORIES CARNEGIE INSTITUTION OF WASHINGTON 813 SANTA BARBARA STREET PASADENA, CA. 91101-1232		DWG NO.	REV.			
				FINISH:			DESIGNER: CINCH	01/23/06				SOCKET,337 POSITION LGA SUPPORT		SOCKET	SHT 1 OF 1
				SCALE:			Drawn: Koch	01/23/06			Drawings Printed on:				
				As Noted											

