

SPUR GEAR-80 PITCH — 1/8" Face Width ■ 20° Pressure Angle

Pin Hub — 1/8", 3/16" Bores ■ Hubless 3/8" Bore

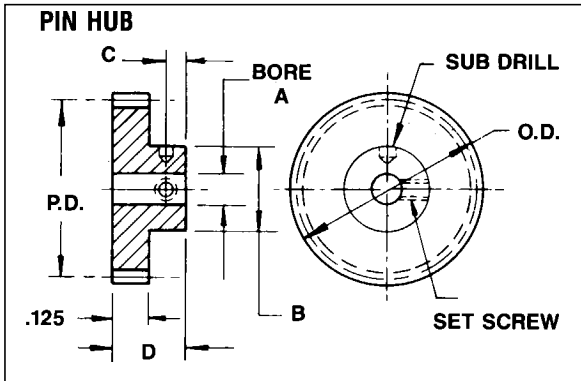

Dimen.	Bore	
	1/8	3/16
A	.1248	.1873
B	.312	.375
C	.09	.11
D	.312	.343
Set Screw	#2-56	#4-40

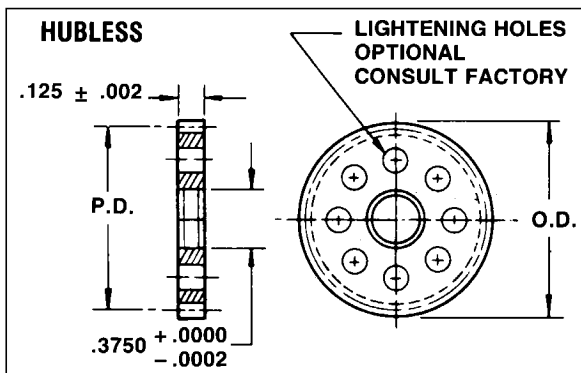

Gear Data			Stainless Steel Part No. Bore Size			Aluminum Part No. Bore Size		
No. Teeth	P.D.	O.D.	Pin Hub		Hubless	Pin Hub		Hubless
			.1248	.1873	.3750	.1248	.1873	.3750
30	.3750	.400	G45-30	—	—	G46-30	—	—
32	.4000	.425	G45-32	—	—	G46-32	—	—
34	.4250	.450	G45-34	—	—	G46-34	—	—
35	.4375	.463	G45-35	—	—	G46-35	—	—
36	.4500	.475	G45-36	—	—	G46-36	—	—
38	.4750	.500	G45-38	G47-38	—	G46-38	G48-38	—
40	.5000	.525	G45-40	G47-40	—	G46-40	G48-40	—
42	.5250	.550	G45-42	G47-42	—	G46-42	G48-42	—
44	.5500	.575	G45-44	G47-44	—	G46-44	G48-44	—
45	.5625	.588	G45-45	G47-45	—	G46-45	G48-45	—
50	.6250	.650	G45-50	G47-50	J25-50	G46-50	G48-50	J26-50
55	.6875	.713	G45-55	G47-55	J25-55	G46-55	G48-55	J26-55
60	.7500	.775	G45-60	G47-60	J25-60	G46-60	G48-60	J26-60
65	.8125	.838	G45-65	G47-65	J25-65	G46-65	G48-65	J26-65
70	.8750	.900	G45-70	G47-70	J25-70	G46-70	G48-70	J26-70
75	.9375	.963	G45-75	G47-75	J25-75	G46-75	G48-75	J26-75
80	1.0000	1.025	G45-80	G47-80	J25-80	G46-80	G48-80	J26-80
85	1.0625	1.088	G45-85	G47-85	J25-85	G46-85	G48-85	J26-85
90	1.1250	1.150	G45-90	G47-90	J25-90	G46-90	G48-90	J26-90
100	1.2500	1.275	G45-100	G47-100	J25-100	G46-100	G48-100	J26-100
110	1.3750	1.400	G45-110	G47-110	J25-110	G46-110	G48-110	J26-110
120	1.5000	1.525	G45-120	G47-120	J25-120	G46-120	G48-120	J26-120
127	1.5875	1.613	G45-127	G47-127	J25-127	G46-127	G48-127	J26-127
130	1.6250	1.650	G45-130	G47-130	J25-130	G46-130	G48-130	J26-130
140	1.7500	1.775	G45-140	G47-140	J25-140	G46-140	G48-140	J26-140
150	1.8750	1.900	—	G47-150	J25-150	—	G48-150	J26-150
160	2.0000	2.025	—	G47-160	J25-160	—	G48-160	J26-160
170	2.1250	2.150	—	G47-170	J25-170	—	G48-170	J26-170
180	2.2500	2.275	—	G47-180	J25-180	—	G48-180	J26-180
190	2.3750	2.400	—	G47-190	J25-190	—	G48-190	J26-190
200	2.5000	2.525	—	G47-200	J25-200	—	G48-200	J26-200
220	2.7500	2.775	—	—	J25-220	—	—	J26-220

Other Size Bores Available, Consult Factory.

For Gear Hubs See Pages 12-65 & 12-66

Material: 303 Stainless Steel
2024-T4 Aluminum
(Anodized Before Cutting)

Tolerances	Q10	Q12	Q14
Bore	+ .0005 - .0000	+ .0003 - .0000	+ .0002 - .0000
Pitch Diameter	+ .000 - .001	+ .0000 - .0007	+ .0000 - .0005
Outside Diameter	+ .000 - .002	+ .0000 - .0015	+ .000 - .001
Total Composite Tolerance	FOR AGMA QUALITY STANDARDS SEE PAGE 12-2		
Tooth to Tooth Tolerance			

To order AGMA 12 Gears, add - Q12 to Part No.
To order AGMA 14 Gears, add - Q14 to Part No.

FOR SPECIAL SPUR GEARS ORDER AS FOLLOWS:

For Unlisted Number of Teeth, Specify the Number of Teeth desired as the last figure in the part number.
EXAMPLE: G47-40 and G47-50 are in the above table. For a 59 Tooth Gear, Specify Part Number G47-59.