

WORM WHEEL - 48 PITCH — 14½°, 20°, 25° Pressure Angle

Right Hand ■ Single, Double & Four Thread ■ Pin Hub, Split Hub — 1/8", 3/16" & 1/4" Bores ■ AGMA Quality No. 10

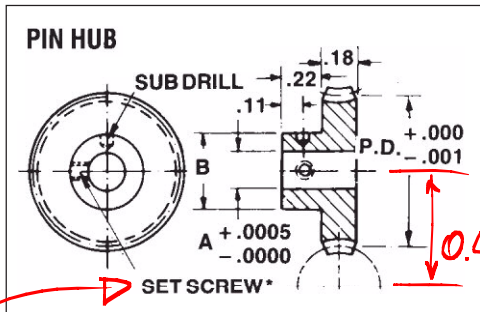

Material: Bronze ASTM B21 Alloy 464

Ratio = $\frac{\text{No. Teeth}}{\text{No. Threads}}$

0.4791

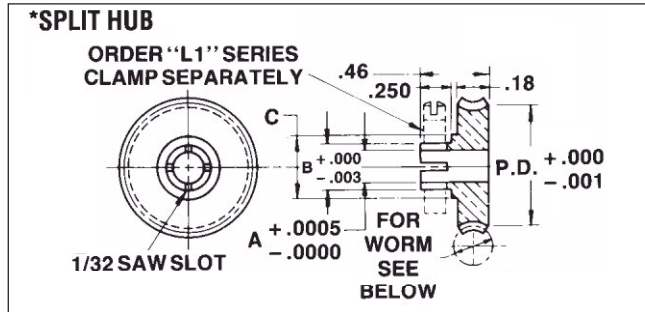

* Set Screw 90° To Subdrill CW/CCW At PIC Option

P.D. = $0.625 \div 2 = 0.3125$ WORM WHEEL
 $0.3333 \div 2 = 0.1666$ WORM
 0.4791

PIN HUB

Gear Data					Single Thread (14½° P.A.)	Double Thread (20° P.A.)	Four Thread (25° P.A.)
No. Teeth	Pitch Dia.	A	B	Set Screw	Part No.	Part No.	Part No.
30	.6250				Q7-14	Q9-14	Q11-14
40	.8333				Q7-15	Q9-15	Q11-15
50	1.0417				Q7-1	Q9-1	Q11-1
60	1.2500				Q7-2	Q9-2	Q11-2
70	1.4583	.1248 (1/8)	.312	#2-56	Q7-16	Q9-16	Q11-16
80	1.6667				Q7-3	Q9-3	Q11-3
90	1.8750				Q7-4	Q9-4	Q11-4
100	2.0833				Q7-17	Q9-17	Q11-17
120	2.5000				Q7-18	Q9-18	Q11-18
30	.6250				Q7-19	Q9-19	Q11-19
40	.8333				Q7-20	Q9-20	Q11-20
50	1.0417				Q7-5	Q9-5	Q11-5
60	1.2500				Q7-6	Q9-6	Q11-6
70	1.4583	.1873 (3/16)	.375	#4-40	Q7-21	Q9-21	Q11-21
80	1.6667				Q7-7	Q9-7	Q11-7
90	1.8750				Q7-8	Q9-8	Q11-8
100	2.0833				Q7-22	Q9-22	Q11-22
120	2.5000				Q7-23	Q9-23	Q11-23
30	.6250				Q7-24	Q9-24	Q11-24
40	.8333				Q7-25	Q9-25	Q11-25
50	1.0417				Q7-9	Q9-9	Q11-9
60	1.2500				Q7-10	Q9-10	Q11-10
70	1.4583	.2498 (1/4)	.500	#6-32	Q7-26	Q9-26	Q11-26
80	1.6667				Q7-11	Q9-11	Q11-11
90	1.8750				Q7-12	Q9-12	Q11-12
100	2.0833				Q7-27	Q9-27	Q11-27
120	2.5000				Q7-28	Q9-28	Q11-28
180	3.7500				Q7-13	Q9-13	Q11-13

Other Numbers of Teeth and Material Available on Request, Consult Factory.

SPLIT HUB

Gear Data						Single Thread (14½° P.A.)	Double Thread (20° P.A.)	Four Thread (25° P.A.)
No. Teeth	Pitch Dia.	A	B	C	Clamp No. (Ref.)	Part No.	Part No.	Part No.
50	1.042					Q7-1-C	Q9-1-C	Q11-1-C
60	1.250	.1248 (1/8)	.188	1/4	L1-4	Q7-2-C	Q9-2-C	Q11-2-C
80	1.667					Q7-3-C	Q9-3-C	Q11-3-C
90	1.875					Q7-4-C	Q9-4-C	Q11-4-C
50	1.042					Q7-5-C	Q9-5-C	Q11-5-C
60	1.250	.1873 (3/16)	.250	5/16	L1-5	Q7-6-C	Q9-6-C	Q11-6-C
80	1.667					Q7-7-C	Q9-7-C	Q11-7-C
90	1.875					Q7-8-C	Q9-8-C	Q11-8-C
50	1.042					Q7-9-C	Q9-9-C	Q11-9-C
60	1.250	.2498 (1/4)	.312	3/8	L1-6	Q7-10-C	Q9-10-C	Q11-10-C
80	1.667					Q7-11-C	Q9-11-C	Q11-11-C
90	1.875					Q7-12-C	Q9-12-C	Q11-12-C
180	3.750					Q7-13-C	Q9-13-C	Q11-13-C

Other Numbers of Teeth and Material Available on Request, Consult Factory.

Single Thread (Q7 Series) Meshes With Q8 Worm Only
 Double Thread (Q9 Series) Meshes With Q10 Worm Only
 Four Thread (Q11 Series) Meshes With Q12 Worm Only

WORM - 48 PITCH — 14½°, 20°, 25° Pressure Angle

Right Hand ■ Single, Double & Four Thread ■ Pin Hub — 1/8" & 3/16" Bores

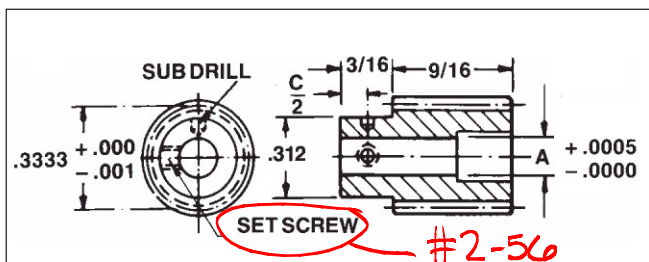

Shaft Size	A	Set Screw	Use With Single Thread (14½° P.A.)	Use With Double Thread (20° P.A.)	Use With Four Thread (25° P.A.)
			Part No.	Part No.	Part No.
1/8	.1248	#2-56	Q8-1	Q10-1	Q12-1
3/16	.1873	#4-40	Q8-2	Q10-2	Q12-2

Material: 303 Stainless Steel

Part No.	Lead	Lead Angle
Q8	.0654	3° 35'
Q10	.1309	7° 7'
Q12	.2618	14° 2'