

PARTS LIST					
ITEM	QTY	PART #	VENDOR	DESCRIPTION	REV
1	1	FS-01-007		ASSY,HEAT SINK BETWEEN OCTAGONS	A
2	1	FS-01-008		ASSY,HEAT SINK BETWEEN OCTAGONS	A
3	1	H2RG-ASSY-1	Teledyne	ASSY,H2RG DETECTOR SYSTEM	BUY
4	1	FS-11-013		SUPPORT,DETECTOR HOLDER,POSITION 1 AND 3	B
5	2	FS-11-039		CLAMP,HEAT SINK TO DETECTOR HOLDER	A
6	8	92146A530	McMaster	SPRING LOCK WASHER No 4	BUY
7	4	92196A106	McMaster	SHCS 4-40 x 0.250	BUY
8	4	90730A005	McMaster	HEX-NUT 4-40	BUY

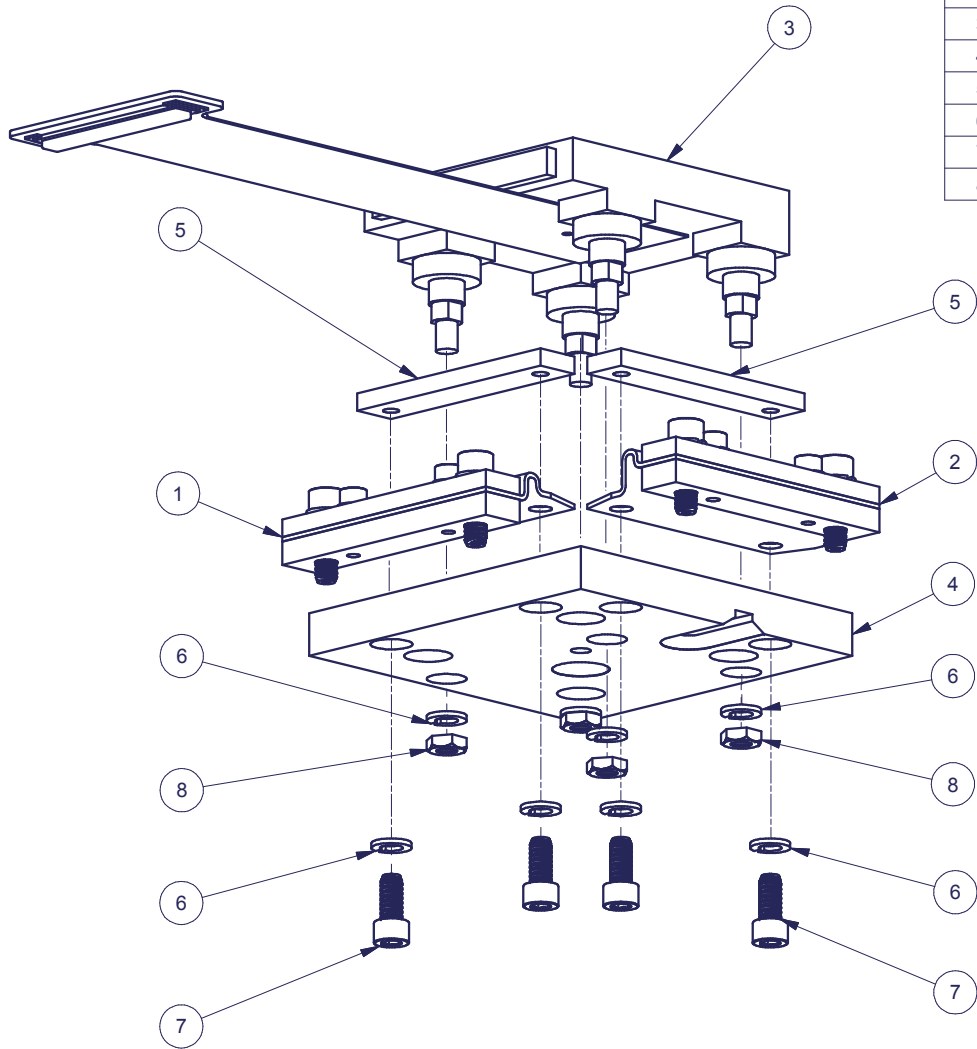

SCALE 1 : 1

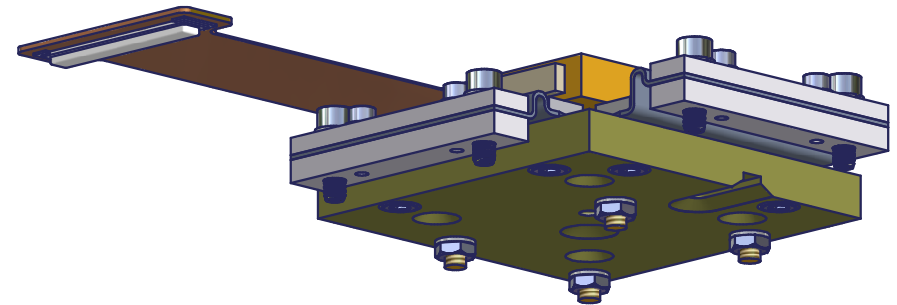

SCALE 1 : 1

REV	CHANGES	DATE	BY	MATERIAL:	UNLESS OTHERWISE SPECIFIED: DIMENSIONS ARE IN INCHES BRAKE EDGES / REMOVE BURRS	**** FourStar	NEXT ASSY	USED ON	THE OBSERVATORIES	
A	Production	6/23/2008	ERK	FINISH: SCALE: As Noted	TOLERANCES: X.X± 0.03 ANGLES:0.5° X.XX± 0.01 FRACTIONS:± 1/16 X.XXX± 0.003	Designer: Persson Drawn: Koch	6/22/2008 6/23/2008	APPLICATION	Drawings Printed on:	CARNEGIE INSTITUTION OF WASHINGTON 813 SANTA BARBARA STREET PASADENA, CA. 91101-1232
								ASSY,H2RG SYSTEM 1	DWG NO. FS-01-009	REV. A SHT 1 OF 1