

ISO TOP RIGHT
SCALE 1 / 2

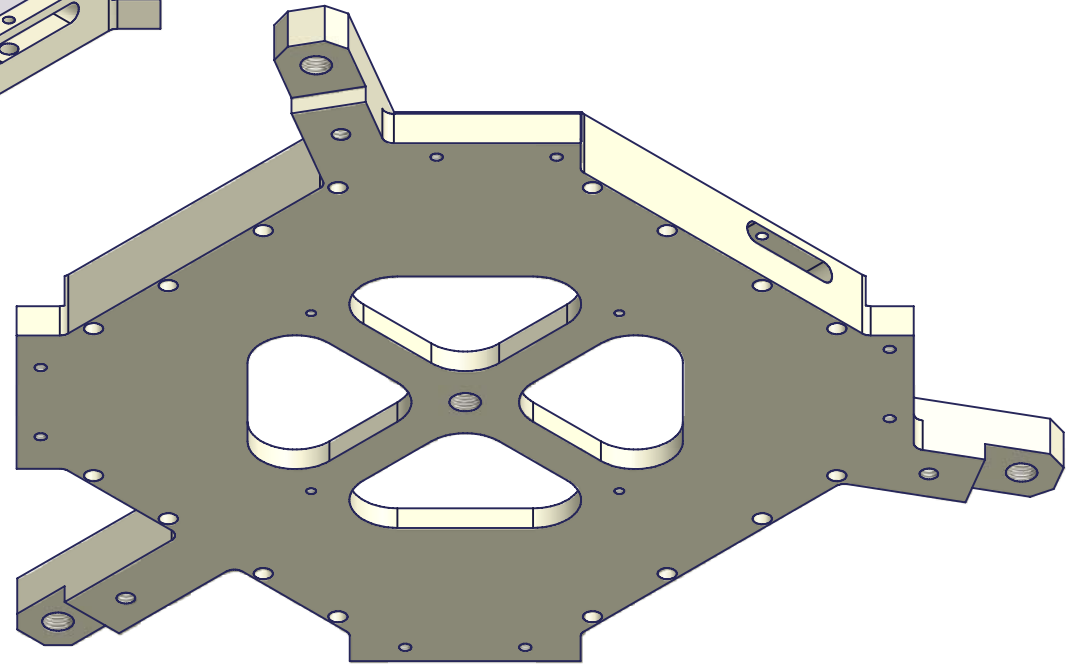

ISO BOTTOM RIGHT
SCALE 1 / 2

- NOTES:
- 1 MATERIAL: AL. ALLOY K100-S
 - 2 FINISH: NONE

REV	CHANGES	DATE	BY	MATERIAL:	UNLESS OTHERWISE SPECIFIED: DIMENSIONS ARE IN INCHES BRAKE EDGES / REMOVE BURRS	**** FourStar	FS-01-001	DETECTOR	THE OBSERVATORIES CARNegie INSTITUTION OF WASHINGTON 813 SANTA BARBARA STREET PASADENA, CA. 91101-1232	
1	First Issue	5/4/2004	ERK	1			NEXT ASSY	USED ON		
2	Hole Pos.	5/8/2004	ERK	FINISH:	TOLERANCES:		APPLICATION		REV. B	
3	Add Dims	5/31/2004	ERK	2	X.X± 0.1 ANGLES:0.5° X.XX± 0.03 FRACTIONS:± 1/16	Designer: Persson	5/3/2004		SHT 1 OF 3	
A	Production	6/10/2004	ERK	SCALE:	DO NOT SCALE DRAWING	Drawn: Koch	5/3/2004	Drawings Printed on:	6/11/2004	FS-11-008
B	3/8-24 holes	6/24/2008	ERK	AS NOTED						

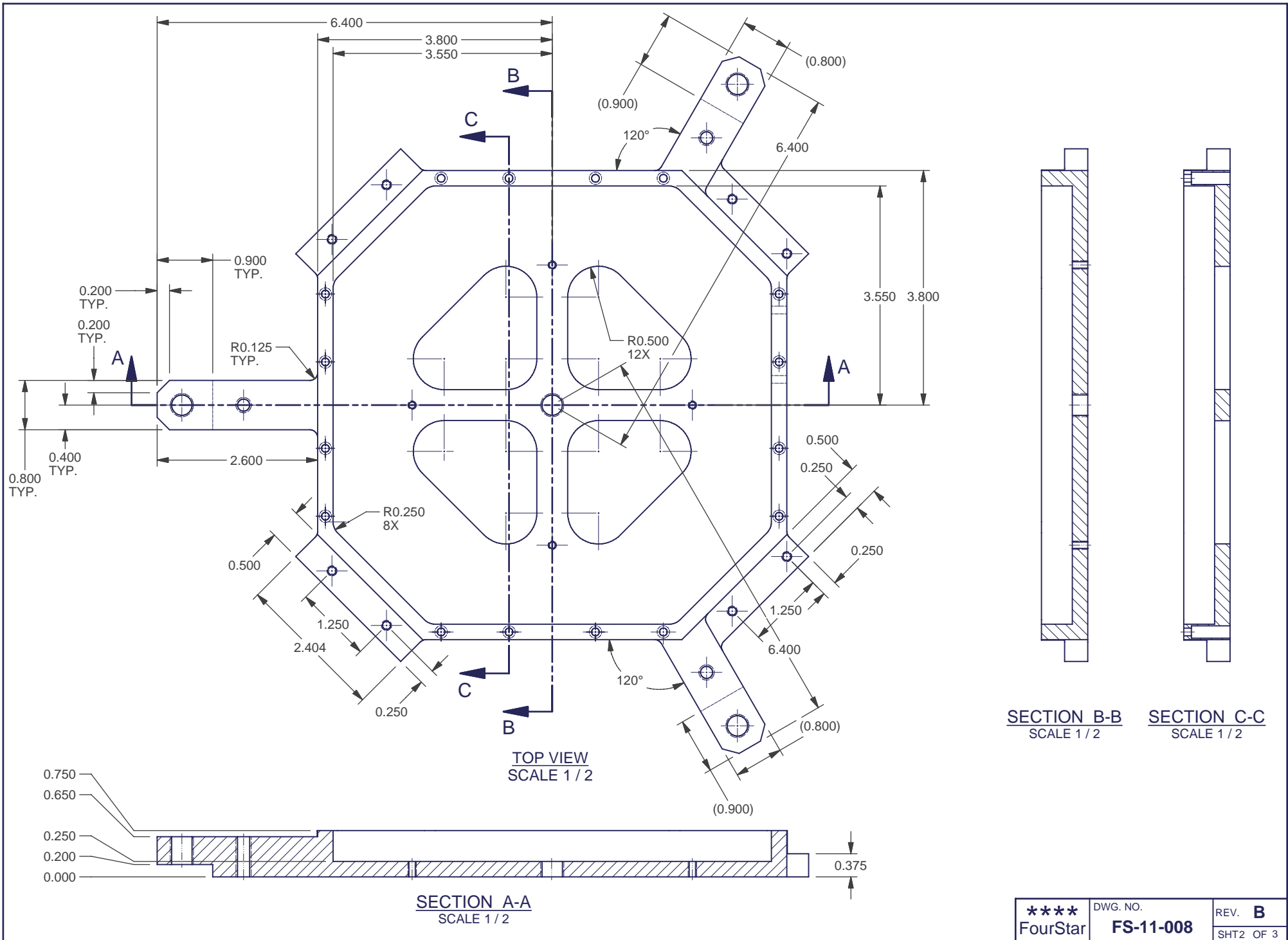

SECTION B-B
 SCALE 1/2

SECTION C-C
 SCALE 1/2

SECTION A-A
 SCALE 1/2

**** FourStar	DWG. NO.	REV. B
	FS-11-008	SHT2 OF 3

