

TOP VIEW
SCALE 2 / 3

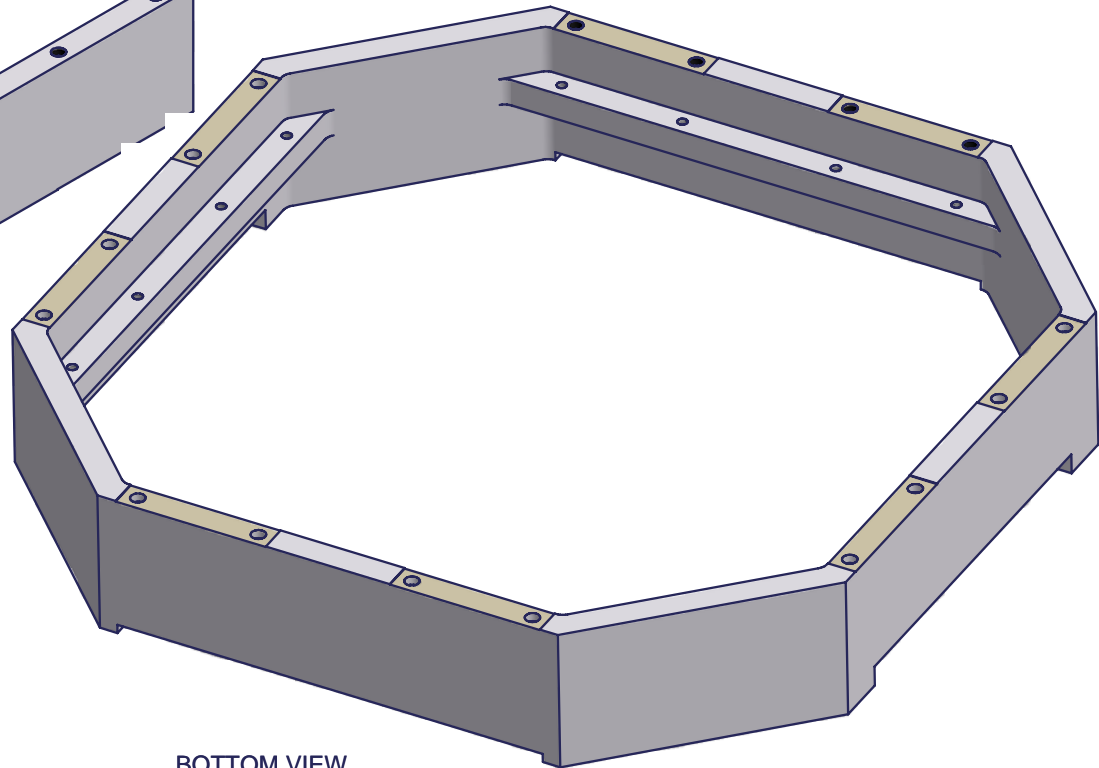

BOTTOM VIEW
SCALE 2 / 3

- 1 NOTES:
 MATERIAL: AL. ALLOY K100-S
 2 FINISH: NONE

REV	CHANGES	DATE	BY	MATERIAL:	UNLESS OTHERWISE SPECIFIED: DIMENSIONS ARE IN INCHES BRAKE EDGES / REMOVE BURRS TOLERANCES: X.X±0.1 ANGLES:0.5° X.XX±0.03 FRACTIONS:± 1/16 X.XXX±0.010 DO NOT SCALE DRAWING	**** FourStar	FS-01-001	DETECTOR	THE OBSERVATORIES CARNEGIE INSTITUTION OF WASHINGTON 813 SANTA BARBARA STREET PASADENA, CA. 91101-1232 SUPPORT, TOP OUTER OCTAGON		DWG NO.	REV. A
1	First Issue	5/1/2004	ERK	1			NEXT ASSY	USED ON			FS-11-009	SHT 1 OF 3
2	HolePos.	5/8/2004	ERK	FINISH:			APPLICATION					
3	Add Dims	5/23/2004	ERK	2			Designer: Persson	4/24/2004				
4	C'BORE	7/9/2004	ERK	SCALE:			Drawn: Koch	4/24/2004			Drawings Printed on:	
A	Production	7/9/2004	ERK	AS NOTED								

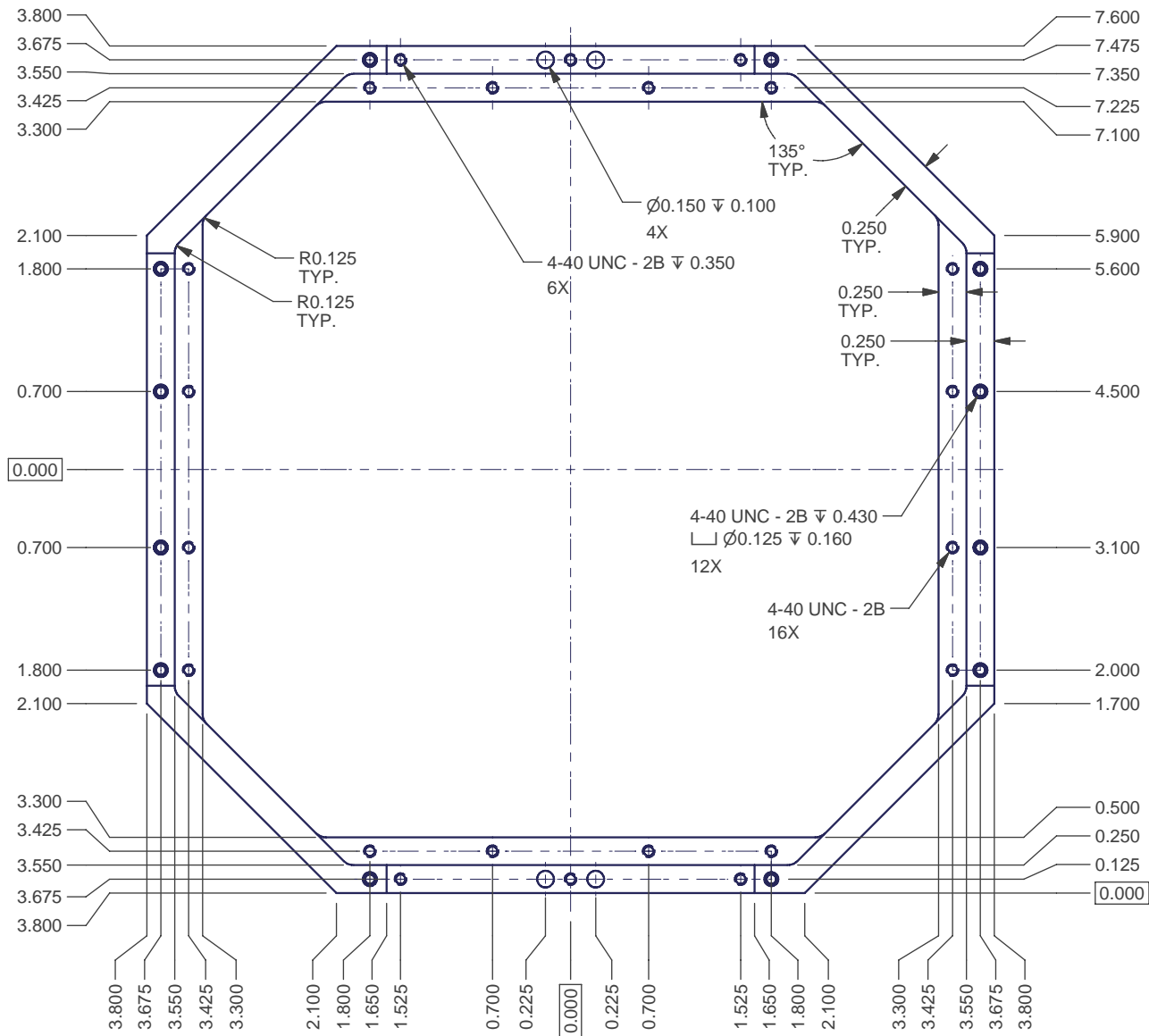

TOP VIEW

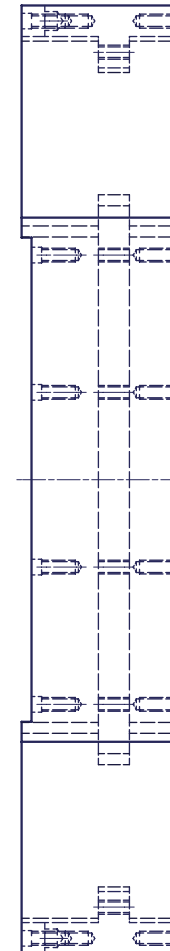
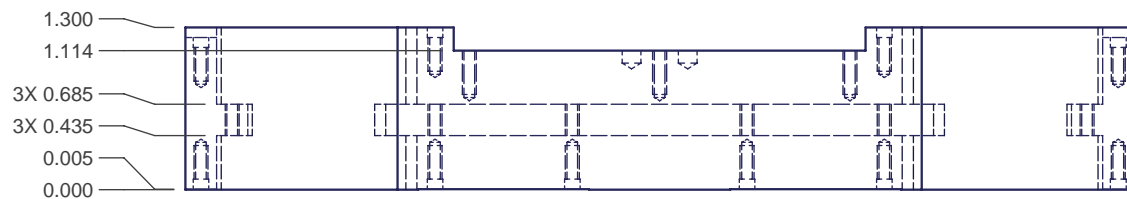

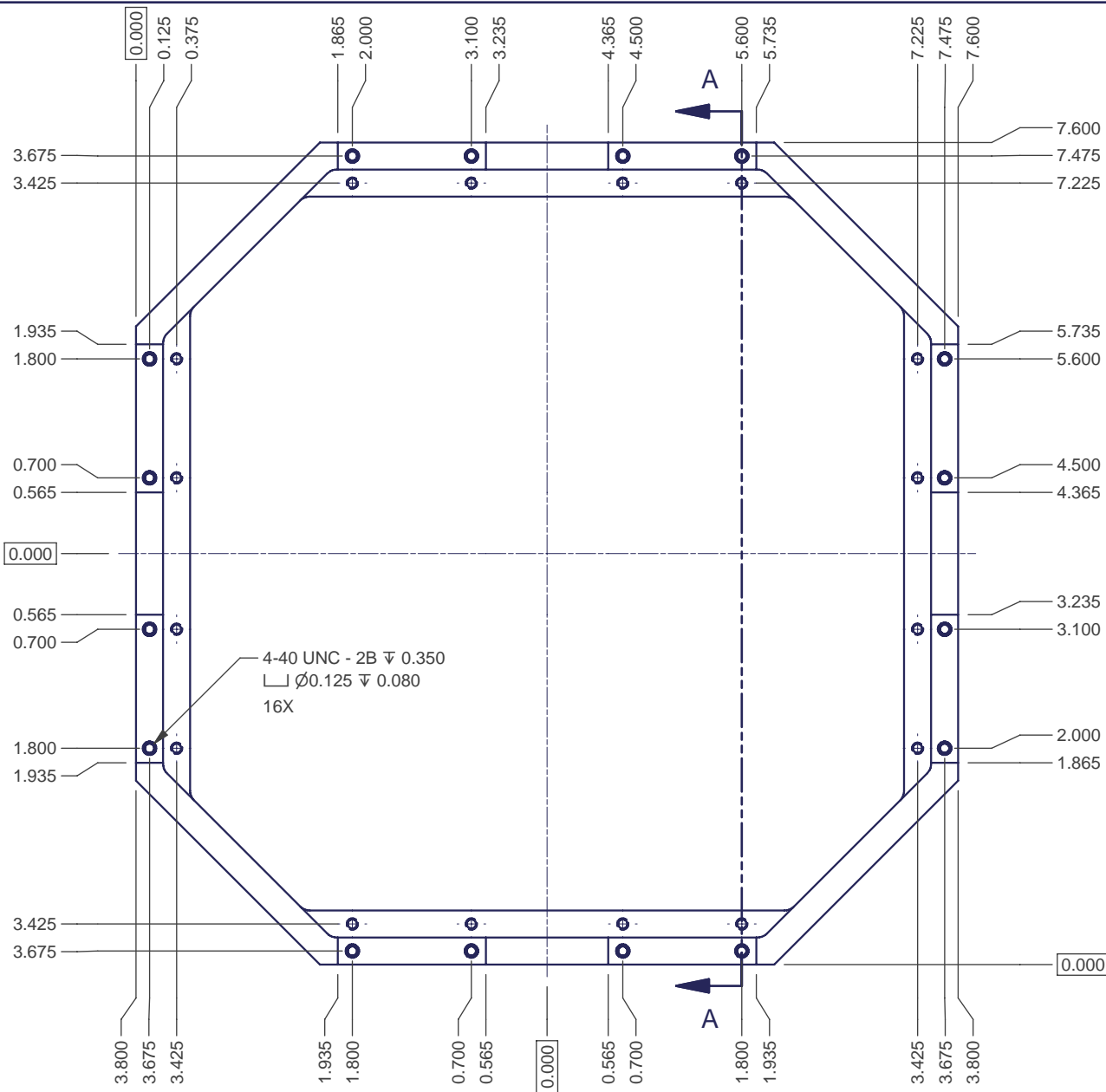

BOTTOM VIEW

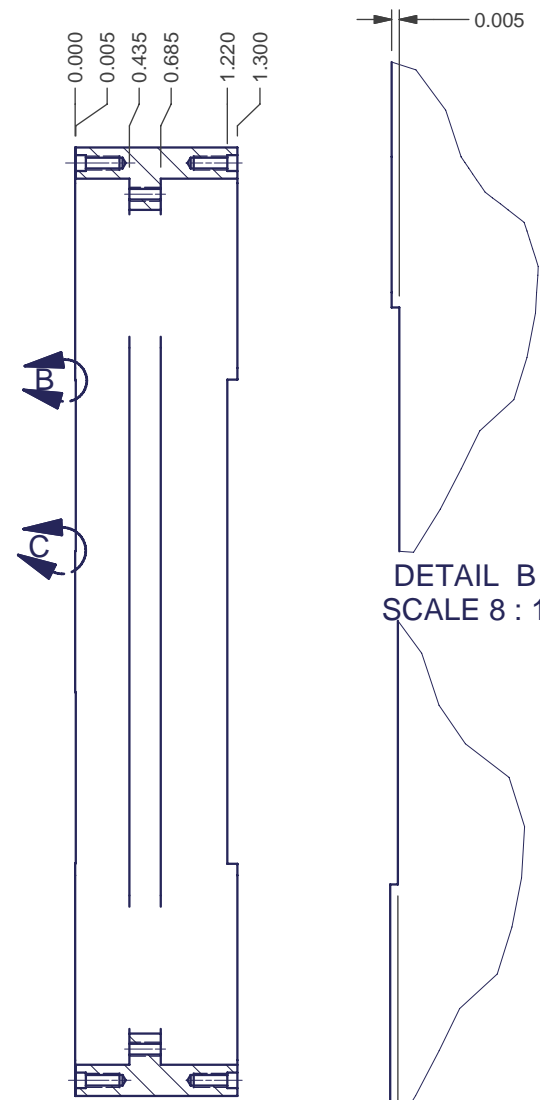

NOTE:
DIMENSIONS ON THE LEFT AND BOTTOM ARE CENTER BASED,
DIMENSIONS ON THE TOP AND RIGHT ARE EDGE BASED.

**** FourStar	DWG. NO.	REV. A
	FS-11-009	SHT3 OF 3