

SCALE 3 : 1

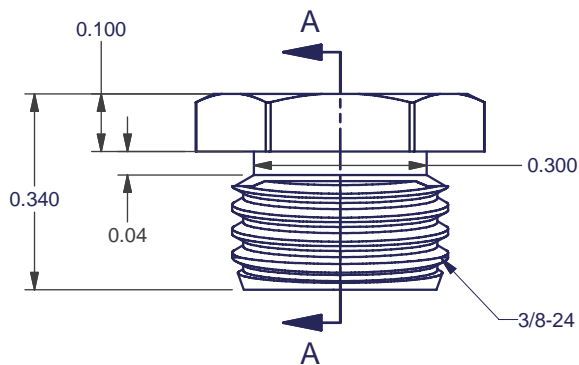

SCALE 3 : 1

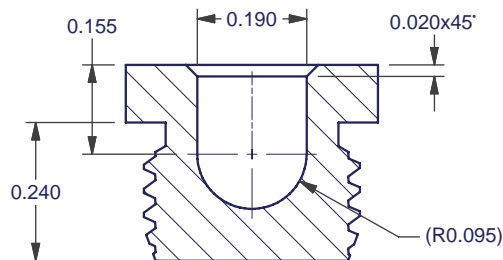

SECTION A-A
SCALE 3 : 1

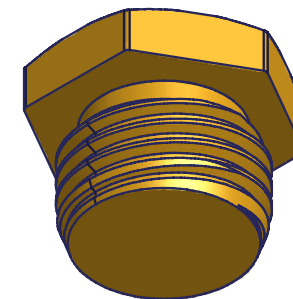

SCALE 3 : 1

NOTES:

- 1 MATERIAL: AL-BRONZE
- 2 FINISH: NONE
- 3 QTY REQ'D: 1

REV	CHANGES	DATE	BY	MATERIAL:	UNLESS OTHERWISE SPECIFIED: DIMENSIONS ARE IN INCHES BRAKE EDGES / REMOVE BURRS	**** FourStar	FS-01-004	DETECTOR	THE OBSERVATORIES CARNEGIE INSTITUTION OF WASHINGTON 813 SANTA BARBARA STREET PASADENA, CA. 91101-1232		DWG NO. FS-11-038	REV. A
NR	Check Print	6/17/2008	ERK	FINISH:			TOLERANCES:	NEXT ASSY				USED ON
A	Production	9/19/2008	ERK	2	X.X± 0.03 ANGLES:0.5°	Designer: Persson	6/16/2008		APPLICATION		3/8-24 SUPPORT, DETECTOR FOCUS	SHT 1 OF 1
				SCALE:	X.XX± 0.01 FRACTIONS:± 1/16	Drawn: Koch	6/17/2008	Drawings Printed on:				
				As Noted	X.XXX± 0.003	DO NOT SCALE DRAWING						