

SCALE 1.25 : 1

NOTES:

- 1 MATERIAL: AL. 6061-T6
- 2 FINISH: NONE
- 3 QTY REQ'D: 2

REV	CHANGES	DATE	BY	MATERIAL:	UNLESS OTHERWISE SPECIFIED: DIMENSIONS ARE IN INCHES BRAKE EDGES / REMOVE BURRS	**** FourStar	FS-02-002	DETENT TOWER	THE OBSERVATORIES CARNEGIE INSTITUTION OF WASHINGTON 813 SANTA BARBARA STREET PASADENA, CA. 91101-1232		
NR	Check Print	07/24/06	ERK	1			TOLERANCES:	NEXT ASSY			
NR1	120 DEG	11/02/06	ERK	FINISH:	X.X± 0.1	ANGLES:0.5°	APPLICATION		DETENT LEVER, TOWER, FILTER WHEEL DWG NO. FS-12-009		
NR2	90 DEG	12/08/06	ERK	2	X.XX± 0.01	FRACTIONS:± 1/16	Designer: Persson	07/19/06			
A	Production	12/08/06	ERK	SCALE: As Noted	X.XXX± 0.003	DO NOT SCALE DRAWING	Drawn: Koch	07/19/06	Drawings Printed on:	11/02/06	REV. A SHT 1 OF 3

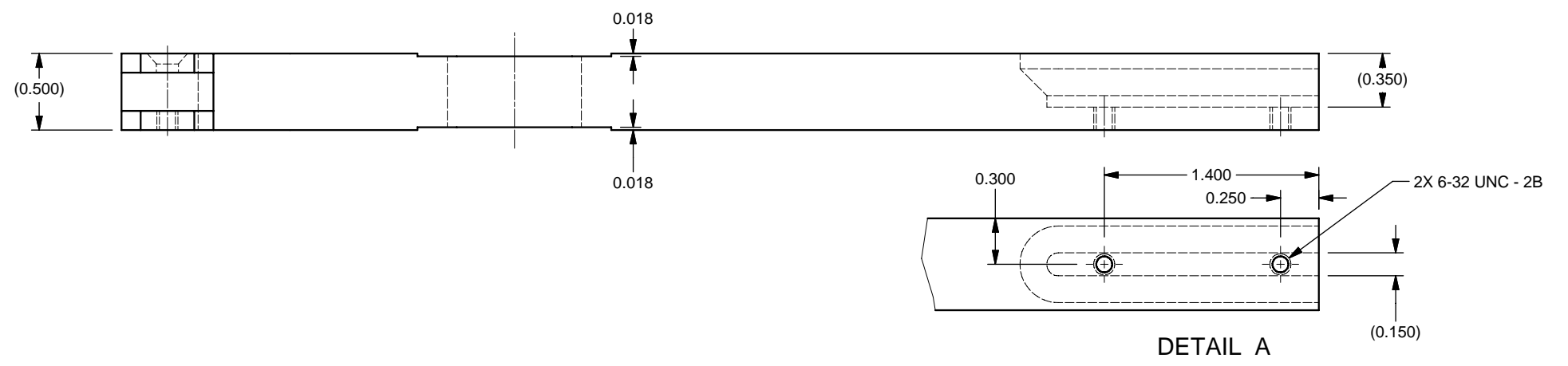
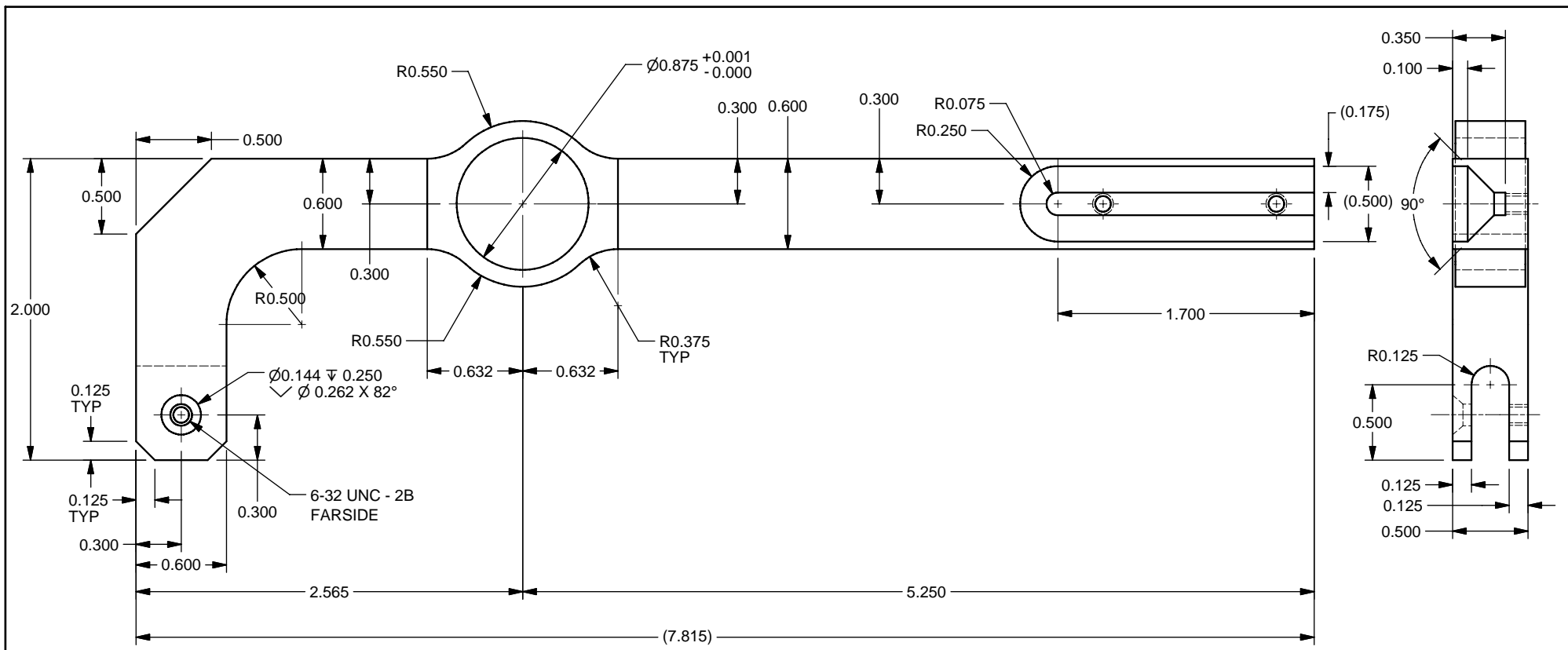

**** FourStar	DWG. NO.	REV. A
	FS-12-009	SHT2 OF 3