

SCALE 1 : 1

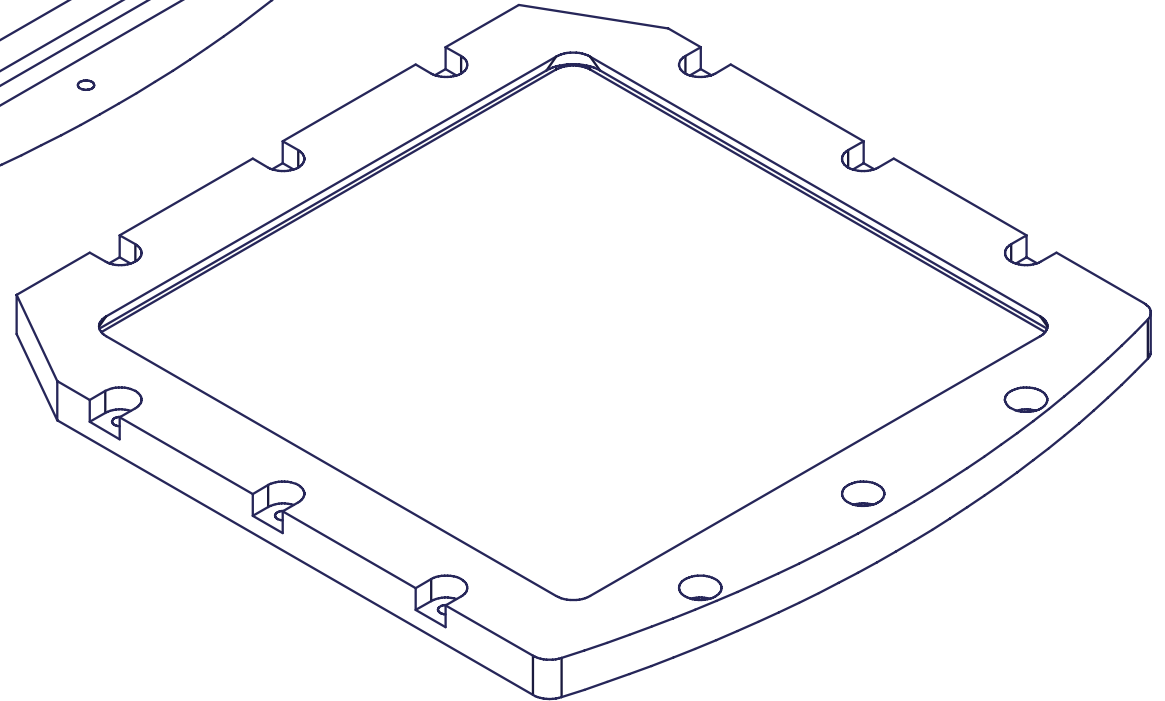

SCALE 1 : 1

NOTES:

- 1 MATERIAL: AL. 6061-T6
- 2 FINISH: NONE
- 3 QTY REQ'D: 10

REV	CHANGES	DATE	BY	MATERIAL:	UNLESS OTHERWISE SPECIFIED: DIMENSIONS ARE IN INCHES BRAKE EDGES / REMOVE BURRS	**** FourStar	FS0-04-004/005	FILTER WHEEL	<h1>THE OBSERVATORIES</h1> <p>CARNEGIE INSTITUTION OF WASHINGTON 813 SANTA BARBARA STREET PASADENA, CA. 91101-1232</p>	
NR	Check Print	8/5/2006	ERK	1			TOLERANCES:	NEXT ASSY		
NR1	BEVEL	6/28/2007	ERK	FINISH:	X.X± 0.1	ANGLES:0.5°	APPLICATION		DWG NO.	
A	Production	9/13/2007	ERK	2	X.XX± 0.01	FRACTIONS:± 1/16	Designer: Persson	9/12/2004		SUPPORT, FILTER TIE DOWN
A1	Add ISO	3/4/2008	EP	SCALE:	X.XXX± 0.003		Drawn: Koch	9/12/2004	Drawings Printed on: 3/4/2008	REV. <b>A1</b>
				As Noted	<b>DO NOT SCALE DRAWING</b>					SHT 1 OF 2

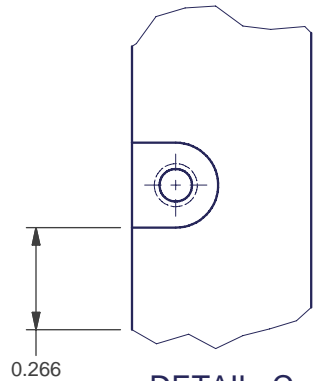

DETAIL C  
SCALE 2 : 1

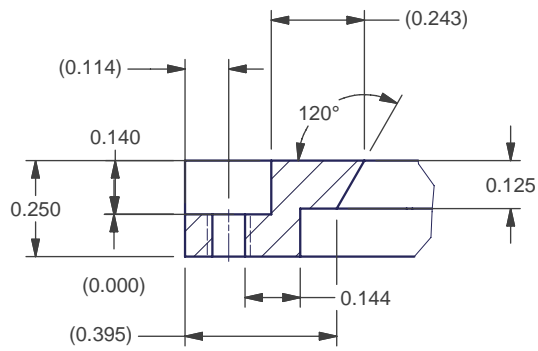

DETAIL B  
SCALE 2 : 1

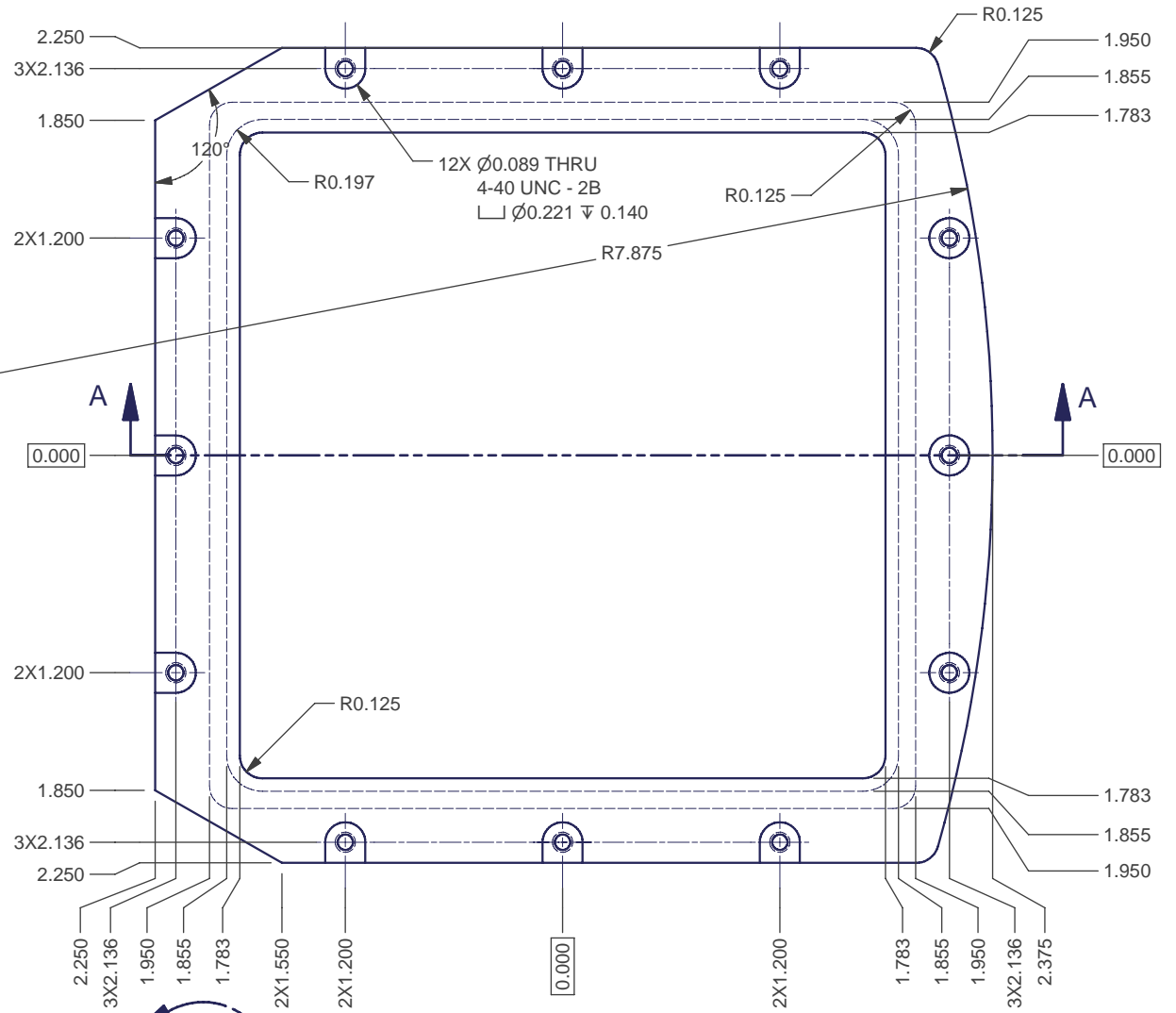

SECTION A-A  
SCALE 1 : 1