

DMC-40x0

Manual Rev. 1.0g

By Galil Motion Control, Inc.

***Galil Motion Control, Inc.
270 Technology Way
Rocklin, California 95765
Phone: (916) 626-0101
Fax: (916) 626-0102
E-mail Address: support@galilmc.com
URL: www.galilmc.com***

Rev 11/09

Using This Manual

This user manual provides information for proper operation of the DMC-40x0 controller. A separate supplemental manual, the Command Reference, contains a description of the commands available for use with this controller.

Your DMC-40x0 motion controller has been designed to work with both servo and stepper type motors. Installation and system setup will vary depending upon whether the controller will be used with stepper motors or servo motors. To make finding the appropriate instructions faster and easier, icons will be next to any information that applies exclusively to one type of system. Otherwise, assume that the instructions apply to all types of systems. The icon legend is shown below.



Attention: Pertains to servo motor use.



Attention: Pertains to stepper motor use.



Attention: Pertains to controllers with more than 4 axes.

Please note that many examples are written for the DMC-4040 four-axes controller or the DMC-4080 eight axes controller. Users of the DMC-4030 3-axis controller, DMC-4020 2-axes controller or DMC-4010 1-axis controller should note that the DMC-4030 uses the axes denoted as XYZ, the DMC-4020 uses the axes denoted as XY, and the DMC-4010 uses the X-axis only.

Examples for the DMC-4080 denote the axes as A,B,C,D,E,F,G,H. Users of the DMC-4050 5-axes controller, DMC-4060 6-axes controller or DMC-4070, 7-axes controller should note that the DMC-4050 denotes the axes as A,B,C,D,E, the DMC-4060 denotes the axes as A,B,C,D,E,F and the DMC-4070 denotes the axes as A,B,C,D,E,F,G. The axes A,B,C,D may be used interchangeably with A,B,C,D.

WARNING: Machinery in motion can be dangerous! It is the responsibility of the user to design effective error handling and safety protection as part of the machinery. Galil shall not be liable or responsible for any incidental or consequential damages.

Contents

Contents	iii
Chapter 1 Overview	1
Introduction	1
Overview of Motor Types	2
Standard Servo Motor with +/- 10 Volt Command Signal	2
Brushless Servo Motor with Sinusoidal Commutation	2
Stepper Motor with Step and Direction Signals	2
Overview of External Amplifiers	3
Amplifiers in Current Mode	3
Amplifiers in Velocity Mode	3
Stepper Motor Amplifiers	3
Overview of Galil Amplifiers and Drivers	3
A1 – AMP-430x0 (-D3040, -D3020)	3
A2 – AMP-43140 (-D3140)	3
A3 – SDM-44040 (-D4040)	3
A4 – SDM-44140 (-D4140)	3
DMC-40x0 Functional Elements	4
Microcomputer Section	4
Motor Interface	4
Communication	4
General I/O	4
System Elements	5
Motor	5
Amplifier (Driver)	5
Encoder	6
Watch Dog Timer	6
Chapter 2 Getting Started	7
DMC-4040 Layout	7
DMC-4080 Layout	8
DMC-40x0 Power Connections	9
DMC-4040 Dimensions	10
DMC-4080 Dimensions	11
Elements You Need	12
Installing the DMC-40x0	13
Step 1. Determine Overall Motor Configuration	13
Step 2. Install Jumpers on the DMC-40x0	14
Step 3. Install the Communications Software	14
Step 4. Connect 20-80VDC Power to the Controller	15
Step 5. Establish Communications with Galil Software	15
Step 6. Determine the Axes to be Used for Sinusoidal Commutation	17
Step 7. Make Connections to Amplifier and Encoder	18
Step 8a. Connect Standard Servo Motors	19
Step 8b. Connect Sinusoidal Commutation Motors	21
Step 8c. Connect Step Motors	24
Step 9. Tune the Servo System	24
Design Examples	25
Example 1 - System Set-up	25
Example 2 - Profiled Move	25

Example 3 - Multiple Axes.....	26
Example 4 - Independent Moves.....	26
Example 5 - Position Interrogation.....	26
Example 6 - Absolute Position.....	26
Example 7 - Velocity Control.....	27
Example 8 - Operation Under Torque Limit.....	27
Example 9 - Interrogation.....	27
Example 10 - Operation in the Buffer Mode.....	28
Example 11 - Using the On-Board Editor.....	28
Example 12 - Motion Programs with Loops.....	28
Example 13 - Motion Programs with Trippoints.....	29
Example 14 - Control Variables.....	29
Example 15 - Linear Interpolation.....	30
Example 16 - Circular Interpolation.....	30

Chapter 3 Connecting Hardware

32

Overview.....	32
Using Optoisolated Inputs.....	32
Limit Switch Input.....	32
Home Switch Input.....	33
Abort Input.....	33
ELO (Electronic Lock-Out) Input.....	34
Reset Input.....	34
Uncommitted Digital Inputs.....	34
Wiring the Optoisolated Inputs.....	34
Electrical Specifications.....	34
Bi-Directional Capability.....	34
Using an Isolated Power Supply.....	36
Bypassing the Opto-Isolation.....	37
TTL Inputs.....	37
The Auxiliary Encoder Inputs.....	37
High Power Opto-Isolated Outputs.....	38
Electrical Specifications.....	38
Wiring the Opto-Isolated Outputs.....	38
Analog Inputs.....	39
AO settings.....	39
Electrical Specifications.....	39
TTL Outputs.....	39
Output Compare.....	39
Error Output.....	39
Extended I/O of the DMC-40x0 Controller.....	40
Electrical Specifications (3.3V – Standard).....	40
Electrical Specifications (5V – Option).....	40
Amplifier Interface.....	41
Electrical Specifications.....	41
Overview.....	41
ICM-42000 and ICM-42100 Amplifier Enable Circuit.....	41
ICM-42200 Amplifier Enable Circuit.....	44

Chapter 4 Software Tools and Communication

48

Introduction.....	48
RS232 and RS422 Ports.....	48
RS-232 Configuration.....	48
RS-422 Configuration.....	50
Ethernet Configuration.....	50
Communication Protocols.....	50
Addressing.....	51
Communicating with Multiple Devices.....	52
Multicasting.....	52
Using Third Party Software.....	52
Modbus.....	53
Modbus Examples.....	54
Data Record.....	55
Explanation Data Record Bit Fields.....	60
Notes Regarding Velocity and Torque Information.....	61
QZ Command.....	61
Controller Response to Commands.....	61
Unsolicited Messages Generated by Controller.....	62

GalilTools (Windows and Linux).....	63
Creating Custom Software Interfaces.....	65
HelloGalil – Quick Start to PC programming.....	65
GalilTools Communication Libraries.....	65
ActiveX Toolkit.....	66
DMCWin Programmers Toolkit.....	66
Galil Communications API with C/C+.....	67
Galil Communications API with Visual Basic.....	67
DOS, and QNX tools.....	69

Chapter 5 Command Basics 70

Introduction.....	70
Command Syntax - ASCII.....	70
Coordinated Motion with more than 1 axis.....	71
Command Syntax – Binary (advanced).....	72
Binary Command Format.....	72
Binary command table.....	73
Controller Response to DATA.....	74
Interrogating the Controller.....	74
Interrogation Commands.....	74
Summary of Interrogation Commands.....	75
Interrogating Current Commanded Values.....	75
Operands.....	75
Command Summary.....	75

Chapter 6 Programming Motion 76

Overview.....	76
Independent Axis Positioning.....	78
Command Summary - Independent Axis.....	78
Operand Summary - Independent Axis.....	78
Independent Jogging.....	80
Command Summary - Jogging.....	80
Operand Summary - Independent Axis.....	81
Position Tracking.....	81
Example - Motion 2:.....	83
Example Motion 4.....	84
Trip Points.....	85
Command Summary – Position Tracking Mode.....	86
Linear Interpolation Mode.....	86
Specifying Linear Segments.....	86
Command Summary - Linear Interpolation.....	88
Operand Summary - Linear Interpolation.....	88
Example - Linear Move.....	89
Example - Multiple Moves.....	90
Vector Mode: Linear and Circular Interpolation Motion.....	91
Specifying the Coordinate Plane.....	91
Specifying Vector Segments.....	91
Additional commands.....	92
Command Summary - Coordinated Motion Sequence.....	94
Operand Summary - Coordinated Motion Sequence.....	94
Electronic Gearing.....	95
Ramped Gearing.....	96
Example – Electronic Gearing Over a Specified Interval.....	97
Command Summary - Electronic Gearing.....	98
Example - Simple Master Slave.....	98
Example - Electronic Gearing.....	98
Example - Gantry Mode.....	98
Electronic Cam.....	99
Command Summary - Electronic CAM.....	103
Operand Summary - Electronic CAM.....	103
Example - Electronic CAM.....	103
PVT Mode.....	105
Specifying PVT Segments.....	105
Exiting PVT Mode.....	105
Error Conditions and Stop Codes.....	105
Additional PVT Information.....	105
Command Summary – PVT.....	106
PVT Examples.....	106

Multi-Axis Coordinated Move.....	108
Contour Mode.....	110
Specifying Contour Segments.....	110
Additional Commands.....	111
Command Summary - Contour Mode.....	111
Stepper Motor Operation.....	115
Specifying Stepper Motor Operation.....	115
Using an Encoder with Stepper Motors.....	116
Command Summary - Stepper Motor Operation.....	116
Operand Summary - Stepper Motor Operation.....	116
Stepper Position Maintenance Mode (SPM).....	117
Internal Controller Commands (user can query):.....	117
User Configurable Commands (user can query & change):.....	117
Error Limit.....	117
Correction.....	117
Dual Loop (Auxiliary Encoder).....	120
Backlash Compensation.....	121
Motion Smoothing.....	122
Using the IT Command.....	122
Using the KS Command (Step Motor Smoothing):.....	124
Homing.....	124
Stage 1:.....	124
Stage 2:.....	124
Stage 3:.....	124
Command Summary - Homing Operation.....	127
Operand Summary - Homing Operation.....	127
High Speed Position Capture (The Latch Function).....	127
Fast Update Rate Mode.....	129

Chapter 7 Application Programming

130

Overview.....	130
Using the DMC-40x0 Editor to Enter Programs.....	130
Edit Mode Commands.....	131
Program Format.....	131
Using Labels in Programs.....	131
Special Labels.....	132
Commenting Programs.....	132
Executing Programs - Multitasking.....	133
Debugging Programs.....	134
Program Flow Commands.....	135
Event Triggers & Trippoints.....	135
Event Trigger Examples:.....	137
Conditional Jumps.....	139
Using If, Else, and Endif Commands.....	141
Subroutines.....	142
Stack Manipulation.....	143
Auto-Start Routine.....	143
Automatic Subroutines for Monitoring Conditions.....	143
JS Subroutine Stack Variables (^a, ^b, ^c, ^d, ^e, ^f, ^g, ^h).....	147
General Program Flow and Timing information.....	150
Mathematical and Functional Expressions.....	152
Mathematical Operators.....	152
Bit-Wise Operators.....	152
Functions.....	153
Variables.....	154
Programmable Variables.....	154
Operands.....	155
Special Operands (Keywords).....	156
Arrays.....	156
Defining Arrays.....	156
Assignment of Array Entries.....	157
Automatic Data Capture into Arrays.....	158
De-allocating Array Space.....	159
Input of Data (Numeric and String).....	159
Input of Data.....	159
Operator Data Entry Mode.....	160
Using Communication Interrupt.....	161
Output of Data (Numeric and String).....	162
Sending Messages.....	162

Displaying Variables and Arrays	164
Interrogation Commands.....	164
Formatting Variables and Array Elements.....	165
Converting to User Units.....	166
Hardware I/O.....	167
Digital Outputs.....	167
Digital Inputs.....	168
The Auxiliary Encoder Inputs.....	168
Input Interrupt Function.....	168
Analog Inputs.....	169
Extended I/O of the DMC-40x0 Controller.....	170
Configuring the I/O of the DMC-40x0.....	170
Saving the State of the Outputs in Non-Volatile Memory.....	171
Accessing Extended I/O.....	171
Example Applications.....	172
Wire Cutter.....	172
X-Y Table Controller.....	173
Speed Control by Joystick.....	175
Position Control by Joystick.....	176
Backlash Compensation by Sampled Dual-Loop.....	176
Chapter 8 Hardware & Software Protection	179
Introduction.....	179
Hardware Protection.....	179
Output Protection Lines.....	179
Input Protection Lines.....	180
Software Protection.....	180
Programmable Position Limits.....	181
Off-On-Error.....	181
Automatic Error Routine.....	181
Limit Switch Routine.....	182
Chapter 9 Troubleshooting	183
Overview.....	183
Installation.....	183
Stability.....	184
Operation.....	184
Chapter 10 Theory of Operation	185
Overview.....	185
Operation of Closed-Loop Systems.....	187
System Modeling.....	188
Motor-Amplifier.....	189
Encoder.....	191
DAC.....	191
Digital Filter.....	192
ZOH.....	193
System Analysis.....	193
System Design and Compensation.....	195
The Analytical Method.....	195
Appendices	199
Electrical Specifications.....	199
Servo Control.....	199
Stepper Control.....	199
Input / Output.....	199
Power Requirements.....	200
+5, +/-12V Power Output Specifications.....	200
Performance Specifications.....	201
Minimum Servo Loop Update Time.....	201
Fast Update Rate Mode.....	202
Ordering Options for the DMC-40x0.....	203
Overview.....	203
DMC-40x0 Controller Board Options.....	203
CMB Communication Board Options.....	204
ICM Interconnect Board Options.....	204

AMP Internal Amplifier Options.....	206
Power Connectors for the DMC-40x0.....	207
Overview.....	207
Molex Part Numbers Used.....	207
Cable Connections for DMC-40x0.....	208
Standard RS-232 Specifications.....	208
DMC-40x0 Serial Cable Specifications.....	209
Pin-Out Description for DMC-40x0.....	210
Configuring the Amplifier Enable Circuit.....	212
ICM-42000 and ICM-42100.....	212
DMC-4040 (Steps 1 and 2).....	212
DMC-4080 (Steps 1 and 2).....	214
DMC-4040 and DMC-4080 (Step 3).....	216
DMC-4040 (Steps 4 and 5).....	223
DMC-4080 (Steps 4 and 5).....	225
Coordinated Motion - Mathematical Analysis.....	227
Example- Communicating with OPTO-22 SNAP-B3000-ENET.....	230
DMC-40x0/DMC-2200 Comparison.....	232
List of Other Publications.....	233
Training Seminars.....	233
Contacting Us.....	234
WARRANTY.....	235

Integrated Components 236

Overview.....	236
A1 – AMP-430x0 (-D3040,-D3020) 2- and 4-axis 500W Servo Drives.....	236
A2 – AMP-43140 (-D3140) 4-axis 20W Linear Servo Drives.....	236
A3 – SDM-44040 (-D4040) 4-axis Stepper Drives.....	236
A4 – SDM-44140 (-D4140) 4-axis Microstep Drives.....	236
A5 – CMB-41012 (-C012) Communications Board.....	236
A6 – ICM-42000 (-I000) Interconnect Module.....	236
A7 – ICM-42100 (-I100) Sinusoidal Encoder Interpolation Module.....	237
A8 – ICM-42200 (-I200) Interconnect Module.....	237

A1 – AMP-430x0 (-D3040,-D3020) 238

Description.....	238
Electrical Specifications.....	239
Mating Connectors.....	239
Operation.....	240
Brushless Motor Setup.....	240
Brushless Amplifier Software Setup.....	240
Chopper Mode.....	240
Brush Amplifier Operation.....	241
Using External Amplifiers.....	241
Error Monitoring and Protection.....	241
Hall Error Protection.....	242
Under-Voltage Protection.....	242
Over-Voltage Protection.....	242
Over-Current Protection.....	242
Over-Temperature Protection.....	243
ELO Input.....	243

A2 – AMP-43140 (-D3140) 244

Description.....	244
Electrical Specifications.....	245
Mating Connectors.....	245
Operation.....	246
Using External Amplifiers.....	246
ELO Input.....	246
-SSR Option.....	246

A3 – SDM-44040 (-D4040) 247

Description.....	247
Electrical Specifications.....	248
Mating Connectors.....	248
Operation.....	249

Current Level Setup (AG Command).....	249
Low Current Setting (LC Command).....	249
Step Drive Resolution Setting (YA command).....	249
ELO Input.....	250
A4 – SDM-44140 (-D4140)	251
Description.....	251
Electrical Specifications.....	252
Mating Connectors.....	252
Operation.....	253
Current Level Setup (AG Command).....	253
Low Current Setting (LC Command).....	253
ELO Input.....	253
A5 – CMB-41012 (-C012)	254
Description.....	254
Connectors for CMB-41012 Interconnect Board.....	254
CMB-41012 Extended I/O 44 pin HD D-Sub Connector (Male).....	254
RS-232-Main Port (Male).....	255
RS-232-Auxiliary Port (Female).....	255
RS-422-Main Port (Non-Standard Option).....	255
RS-422-Auxiliary Port (Non-Standard Option).....	256
Ethernet.....	256
Jumper Description for CMB-41012.....	257
A6 – ICM-42000 (-I000)	258
Description.....	258
Connectors for ICM-42000 Interconnect Board.....	258
ICM-42000 I/O (A-D) 44 pin HD D-Sub Connector (Female).....	258
ICM-42000 I/O (E-H) 44 pin HD D-Sub Connector (Female).....	259
ICM-42000 External Driver (A-D) 44 pin HD D-Sub Connector (Male).....	259
ICM-42000 External Driver (E-H) 44 pin HD D-Sub Connector (Male).....	260
ICM-42000 Encoder 15 pin HD D-Sub Connector (Female).....	261
ICM-42000 Analog 15 pin D-sub Connector (Male).....	261
Jumper Description for ICM-42000.....	262
A7 – ICM-42100 (-I100)	263
Description.....	263
Connectors for ICM-42100 Interconnect Board.....	264
ICM-42100 I/O (A-D) 44 pin HD D-Sub Connector (Female).....	264
ICM-42100 I/O (E-H) 44 pin HD D-Sub Connector (Female).....	264
ICM-42100 External Driver (A-D) 44 pin HD D-Sub Connector (Male).....	265
ICM-42100 External Driver (E-H) 44 pin HD D-Sub Connector (Male).....	266
ICM-42100 Encoder 15 pin HD D-Sub Connector (Female).....	267
ICM-42100 Analog 15 pin D-sub Connector (Male).....	267
Theory of Operation.....	268
A8 – ICM-42200 (-I200)	270
Description.....	270
Connectors for ICM-42200 Interconnect Board.....	270
ICM-42200 I/O (A-D) 44 pin HD D-Sub Connector (Female).....	270
ICM-42200 DMC-40x0 I/O (E-H) 44 pin HD D-Sub Connector (Female).....	271
ICM-42200 Encoder 26 pin HD D-Sub Connector (Female).....	271
ICM-42200 Analog 15 pin D-sub Connector (Male).....	272
Jumper Description for ICM-42200.....	272
Index	273

Chapter 1 Overview

Introduction

The DMC-40x0 Series are Galil's highest performance stand-alone controller. The controller series offers many enhanced features including high speed communications, non-volatile program memory, faster encoder speeds, and improved cabling for EMI reduction.

Each DMC-40x0 provides two communication channels: high speed RS-232 (2 channels up to 115K Baud) and 10BaseT Ethernet. The controllers allow for high-speed servo control up to 22 million encoder counts/sec and step motor control up to 6 million steps per second. Sample rates as low as 31.25 μ sec per axis are available.

A Flash EEPROM provides non-volatile memory for storing application programs, parameters, arrays and firmware. New firmware revisions are easily upgraded in the field.

The DMC-40x0 is available with up to eight axes in a single stand alone unit. The DMC-4010, 4020, 4030, 4040 are one thru four axes controllers and the DMC-4050, 4060, 4070, 4080 are five thru eight axes controllers. All eight axes have the ability to use Galil's integrated amplifiers or drivers and connections for integrating external devices.

Designed to solve complex motion problems, the DMC-40x0 can be used for applications involving jogging, point-to-point positioning, vector positioning, electronic gearing, multiple move sequences, and contouring. The controller eliminates jerk by programmable acceleration and deceleration with profile smoothing. For smooth following of complex contours, the DMC-40x0 provides continuous vector feed of an infinite number of linear and arc segments. The controller also features electronic gearing with multiple master axes as well as gantry mode operation.

For synchronization with outside events, the DMC-40x0 provides uncommitted I/O, including 8 opto-isolated digital inputs (16 inputs for DMC-4050 thru DMC-4080), 8 high power optically isolated outputs (16 outputs for DMC-4050 thru DMC-4080), and 8 analog inputs for interface to joysticks, sensors, and pressure transducers. The DMC-40x0 also has an additional 32 I/O at 3.3V logic. Further I/O is available if the auxiliary encoders are not being used (2 inputs / each axis). Dedicated optoisolated inputs are provided for forward and reverse limits, abort, home, and definable input interrupts.

Commands can be sent in either Binary or ASCII. Additional software is available for automatic-tuning, trajectory viewing on a PC screen, CAD translation, and program development using many environments such as Visual Basic, C, C++ etc. Drivers for Windows XP (32 & 64 bit).

Overview of Motor Types

The DMC-40x0 can provide the following types of motor control:

1. Standard servo motors with +/- 10 volt command signals
2. Brushless servo motors with sinusoidal commutation
3. Step motors with step and direction signals
4. Other actuators such as hydraulics - For more information, contact Galil.

The user can configure each axis for any combination of motor types, providing maximum flexibility.

Standard Servo Motor with +/- 10 Volt Command Signal

The DMC-40x0 achieves superior precision through use of a 16-Bit motor command output DAC and a sophisticated PID filter that features velocity and acceleration feed-forward, an extra pole filter and integration limits.

The controller is configured by the factory for standard servo motor operation. In this configuration, the controller provides an analog signal (+/- 10 volts) to connect to a servo amplifier. This connection is described in Chapter 2.

Brushless Servo Motor with Sinusoidal Commutation

The DMC-40x0 can provide sinusoidal commutation for brushless motors (BLM). In this configuration, the controller generates two sinusoidal signals for connection with amplifiers specifically designed for this purpose.

Note: The task of generating sinusoidal commutation may be accomplished in the brushless motor amplifier. If the amplifier generates the sinusoidal commutation signals, only a single command signal is required and the controller should be configured for a standard servo motor (described above).

Sinusoidal commutation in the controller can be used with linear and rotary BLMs. However, the motor velocity should be limited such that a magnetic cycle lasts at least 6 milliseconds with a standard update rate of 1 millisecond. For faster motors, please contact the factory.

To simplify the wiring, the controller provides a one-time, automatic set-up procedure. When the controller has been properly configured, the brushless motor parameters may be saved in non-volatile memory.

The DMC-40x0 can control BLMs equipped with Hall sensors as well as without Hall sensors. If Hall sensors are available, once the controller has been setup, the brushless motor parameters may be saved in non-volatile memory. In this case, the controller will automatically estimate the commutation phase upon reset. This allows the motor to function immediately upon power up. The Hall effect sensors also provide a method for setting the precise commutation phase. Chapter 2 describes the proper connection and procedure for using sinusoidal commutation of brushless motors.

Stepper Motor with Step and Direction Signals



The DMC-40x0 can control stepper motors. In this mode, the controller provides two signals to connect to the stepper motor: Step and Direction. For stepper motor operation, the controller does not require an encoder and operates the stepper motor in an open loop fashion. Chapter 2 describes the proper connection and procedure for using stepper motors.

If encoders are available on the stepper motor, Galil's Stepper Position Maintenance Mode may be used for automatic monitoring and correction of the stepper position. See Stepper Position Maintenance Mode (SPM) in Chapter 6 for more information.

Overview of External Amplifiers

The amplifiers should be suitable for the motor and may be linear or pulse-width-modulated. An amplifier may have current feedback, voltage feedback or velocity feedback.

Amplifiers in Current Mode

Amplifiers in current mode should accept an analog command signal in the +/-10 volt range. The amplifier gain should be set such that a +10V command will generate the maximum required current. For example, if the motor peak current is 10A, the amplifier gain should be 1 A/V.

Amplifiers in Velocity Mode

For velocity mode amplifiers, a command signal of 10 volts should run the motor at the maximum required speed. The velocity gain should be set such that an input signal of 10V runs the motor at the maximum required speed.

Stepper Motor Amplifiers



For step motors, the amplifiers should accept step and direction signals.

Overview of Galil Amplifiers and Drivers

With the DMC-40x0 Galil offers a variety of Servo Amplifiers and Stepper Drivers that are integrated into the same enclosure as the controller. Using the Galil Amplifiers and Drivers provides a simple straightforward motion control solution in one box.

A1 – AMP-430x0 (-D3040, -D3020)

The AMP-43040 (four-axis) and AMP-43020 (two-axis) are multi-axis brush/brushless amplifiers that are capable of handling 500 watts of continuous power per axis. The AMP-43040/43020 Brushless drive modules are connected to a DMC-40x0. The standard amplifier accepts DC supply voltages from 18-80 VDC.

A2 – AMP-43140 (-D3140)

The AMP-43140 contains four linear drives for operating small brush-type servo motors. The AMP-43140 requires a ± 12 –30 DC Volt input. Output power is 20 W per amplifier or 60 W total. The gain of each transconductance linear amplifier is 0.1 A/V at 1 A maximum current. The typical current loop bandwidth is 4 kHz.

A3 – SDM-44040 (-D4040)

The SDM-44040 is a stepper driver module capable of driving up to four bipolar two-phase stepper motors. The current is selectable with options of 0.5, 0.75, 1.0, and 1.4 Amps/Phase. The step resolution is selectable with options of full, half, 1/4 and 1/16.

A4 – SDM-44140 (-D4140)

The SDM-44140 microstepper module drives four bipolar two-phase stepper motors with 1/64 microstep resolution (the SDM-44140 drives two). The current is selectable with options of 0.5, 1.0, 2.0, & 3.0 Amps per axis.

DMC-40x0 Functional Elements

The DMC-40x0 circuitry can be divided into the following functional groups as shown in Figure 1.1 and discussed below.

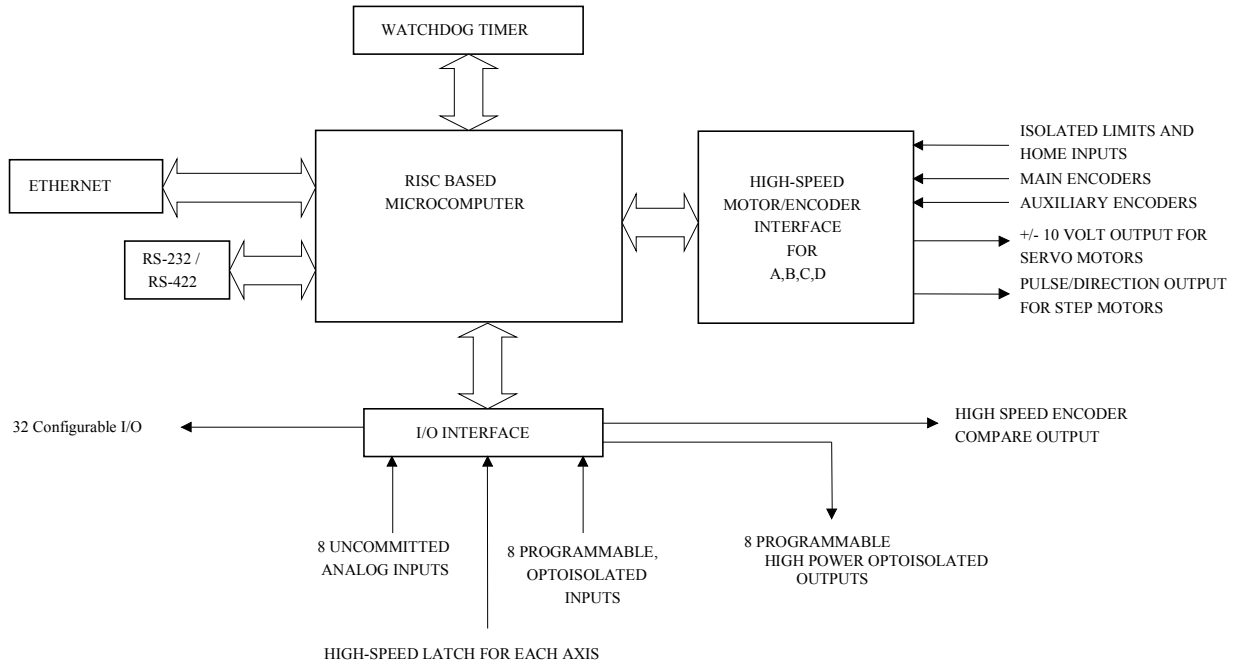

Figure 1.1 - DMC-40x0 Functional Elements

Microcomputer Section

The main processing unit of the controller is a specialized Microcomputer with RAM and Flash EEPROM. The RAM provides memory for variables, array elements, and application programs. The flash EEPROM provides non-volatile storage of variables, programs, and arrays. The Flash also contains the firmware of the controller, which is field upgradeable.

Motor Interface

Galil's GL-1800 custom, sub-micron gate array performs quadrature decoding of each encoder at up to 12 MHz. For standard servo operation, the controller generates a +/-10 volt analog signal (16 Bit DAC). For sinusoidal commutation operation, the controller uses two DACs to generate two +/-10 volt analog signals. For stepper motor operation, the controller generates a step and direction signal.

Communication

The communication interface with the DMC-40x0 consists of high speed RS-232 and Ethernet. The Ethernet is 10/100Bt and the two RS-232 channels can generate up to 115K.

General I/O

The DMC-40x0 provides interface circuitry for 8 bi-directional, optoisolated inputs, 8 high power optoisolated outputs and 8 analog inputs with 12-Bit ADC (16-Bit optional). The DMC-40x0 also has an additional 32 I/O (3.3V

logic) and unused auxiliary encoder inputs may also be used as additional inputs (2 inputs / each axis). The general inputs can also be used as high speed latches for each axis. A high speed encoder compare output is also provided.

4080

The DMC-4050 through DMC-4080 controller provides an additional 8 optoisolated inputs and 8 high power optoisolated outputs.

System Elements

As shown in Fig. 1.2, the DMC-40x0 is part of a motion control system which includes amplifiers, motors and encoders. These elements are described below.

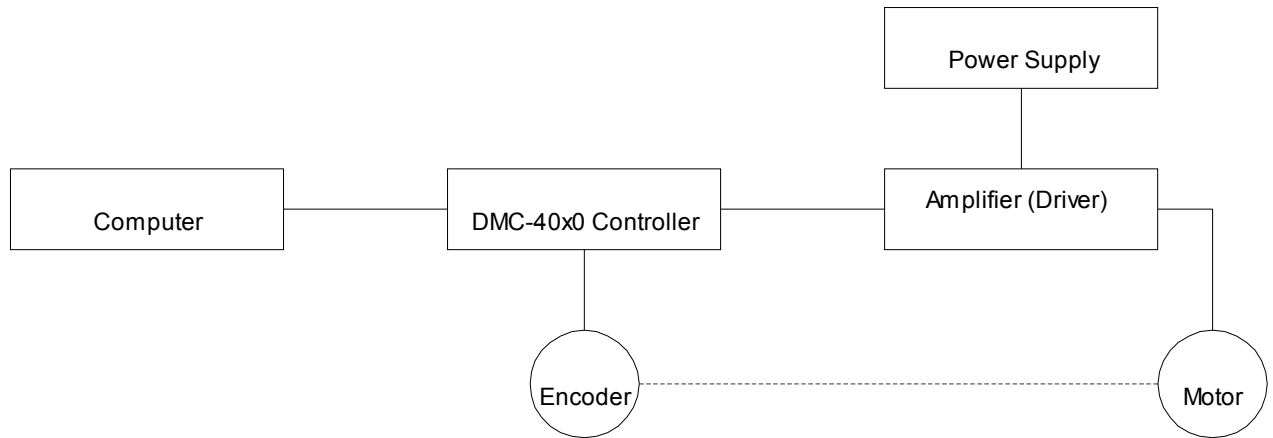

Figure 1-2 - Elements of Servo systems

Motor

A motor converts current into torque which produces motion. Each axis of motion requires a motor sized properly to move the load at the required speed and acceleration. (Galil's MotorSizer Web tool can help you with motor sizing: www.galilmc.com/support/motorsizer)

The motor may be a step or servo motor and can be brush-type or brushless, rotary or linear. For step motors, the controller can be configured to control full-step, half-step, or microstep drives. An encoder is not required when step motors are used.

Other motors and devices such as Ultrasonic Ceramic motors and voice coils can be controlled with the DMC-40x0.

Amplifier (Driver)

For each axis, the power amplifier converts a +/-10 volt signal from the controller into current to drive the motor. For stepper motors, the amplifier converts step and direction signals into current. The amplifier should be sized properly to meet the power requirements of the motor. For brushless motors, an amplifier that provides electronic commutation is required or the controller must be configured to provide sinusoidal commutation. The amplifiers may be either pulse-width-modulated (PWM) or linear. They may also be configured for operation with or without a tachometer. For current amplifiers, the amplifier gain should be set such that a 10 volt command generates the maximum required current. For example, if the motor peak current is 10A, the amplifier gain should be 1 A/V. For velocity mode amplifiers, 10 volts should run the motor at the maximum speed.

Galil offers amplifiers that are integrated into the same enclosure as the DMC-40x0. See the Integrated section in the Appendices or <http://galilmc.com/products/accelera/dmc40x0.html> for more information.

Encoder

An encoder translates motion into electrical pulses which are fed back into the controller. The DMC-40x0 accepts feedback from either a rotary or linear encoder. Typical encoders provide two channels in quadrature, known as CHA and CHB. This type of encoder is known as a quadrature encoder. Quadrature encoders may be either single-ended (CHA and CHB) or differential (CHA,CHA- and CHB,CHB-). The DMC-40x0 decodes either type into quadrature states or four times the number of cycles. Encoders may also have a third channel (or index) for synchronization.

The DMC-40x0 can be ordered with 120 Ohm termination resistors installed on the encoder inputs. See the Ordering Options for the DMC-40x0 in the Appendix for more information.

The DMC-40x0 can also interface to encoders with pulse and direction signals. Refer to the “CE” command in the command reference for details.

There is no limit on encoder line density; however, the input frequency to the controller must not exceed 5,500,000 full encoder cycles/second (22,000,000 quadrature counts/sec). For example, if the encoder line density is 10,000 cycles per inch, the maximum speed is 300 inches/second. If higher encoder frequency is required, please consult the factory.

The standard encoder voltage level is TTL (0-5v), however, voltage levels up to 12 Volts are acceptable. (If using differential signals, 12 Volts can be input directly to the DMC-40x0. Single-ended 12 Volt signals require a bias voltage input to the complementary inputs).

The DMC-40x0 can accept analog feedback (+/-10v) instead of an encoder for any axis. For more information see the command AF in the command reference.

To interface with other types of position sensors such as absolute encoders, Galil can customize the controller and command set. Please contact Galil to talk to one of our applications engineers about your particular system requirements.

Sinusoidal Encoders

The DMC-40x0 can be ordered with an interconnect module that supports the use of 1Vp-p sinusoidal encoders. This interconnect module is the ICM-42100. See A7 – ICM-42100 (-I100) in the Appendix for more information.

Watch Dog Timer

The DMC-40x0 provides an internal watch dog timer which checks for proper microprocessor operation. The timer toggles the Amplifier Enable Output (AMPEN) which can be used to switch the amplifiers off in the event of a serious DMC-40x0 failure. The AMPEN output is normally high. During power-up and if the microprocessor ceases to function properly, the AMPEN output will go low. The error light will also turn on at this stage. A reset is required to restore the DMC-40x0 to normal operation. Consult the factory for a Return Materials Authorization (RMA) Number if your DMC-40x0 is damaged.

Chapter 2 Getting Started

DMC-4040 Layout

The following layouts assume either an ICM-42000(I000) or ICM-42100(I100) interconnect modules are installed. For layouts of systems with ICM-42200's(I200) installed please contact Galil. Overall dimensions and footprint are identical, the only differences are in connector type and location.

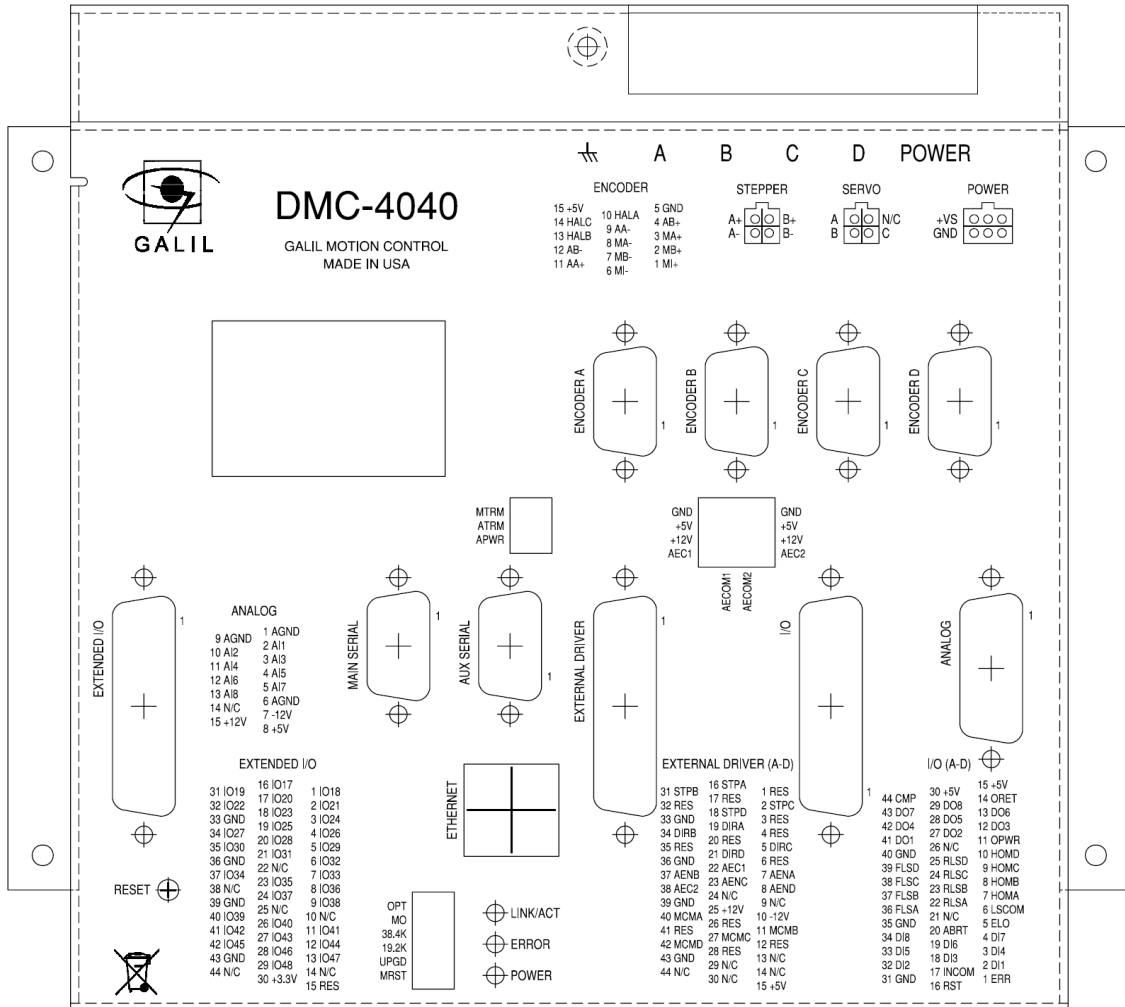

Figure 2-1 - Outline of the the DMC-4040

DMC-4080 Layout

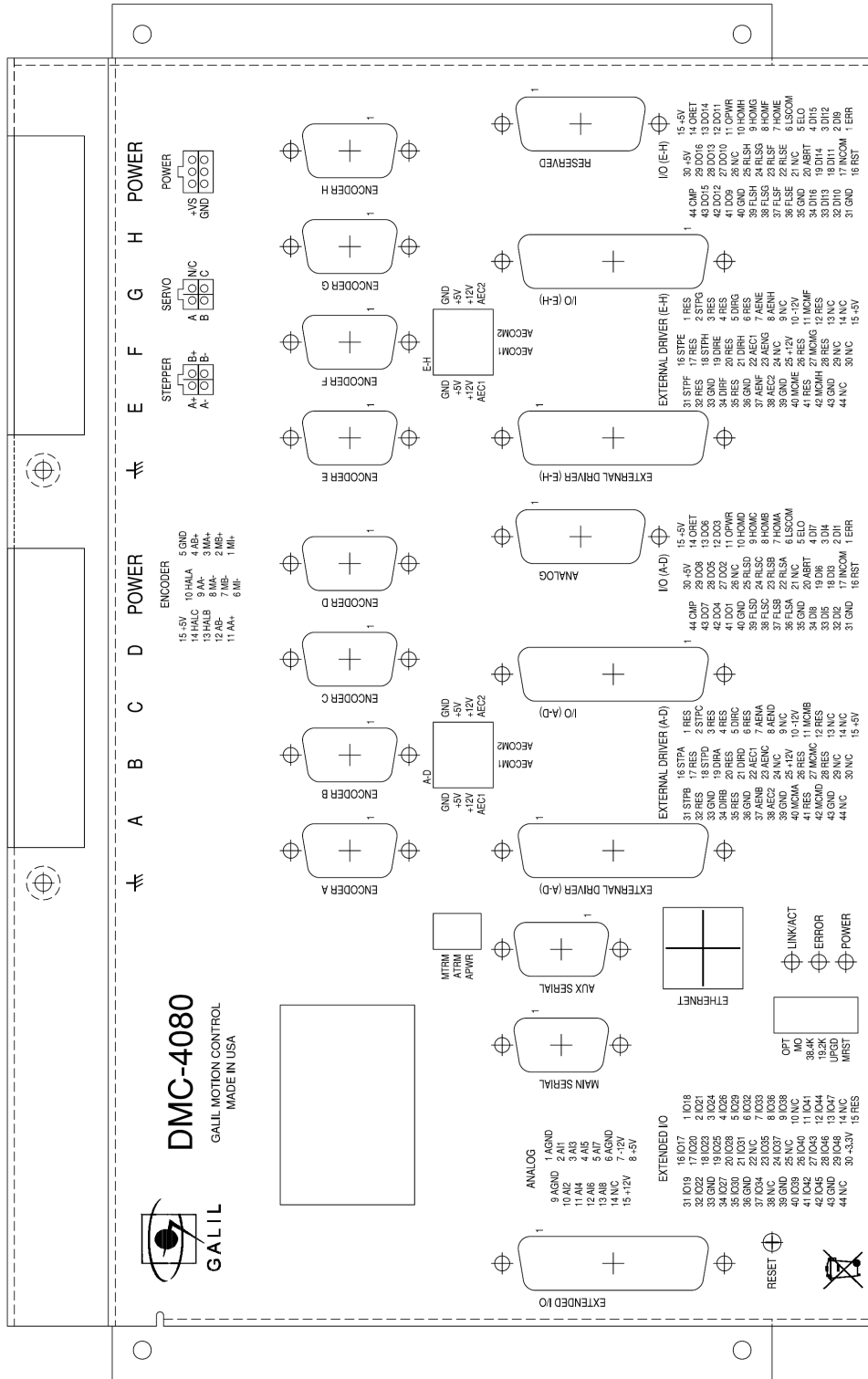

Figure 2-2 - Outline of the DMC-4080

DMC-40x0 Power Connections

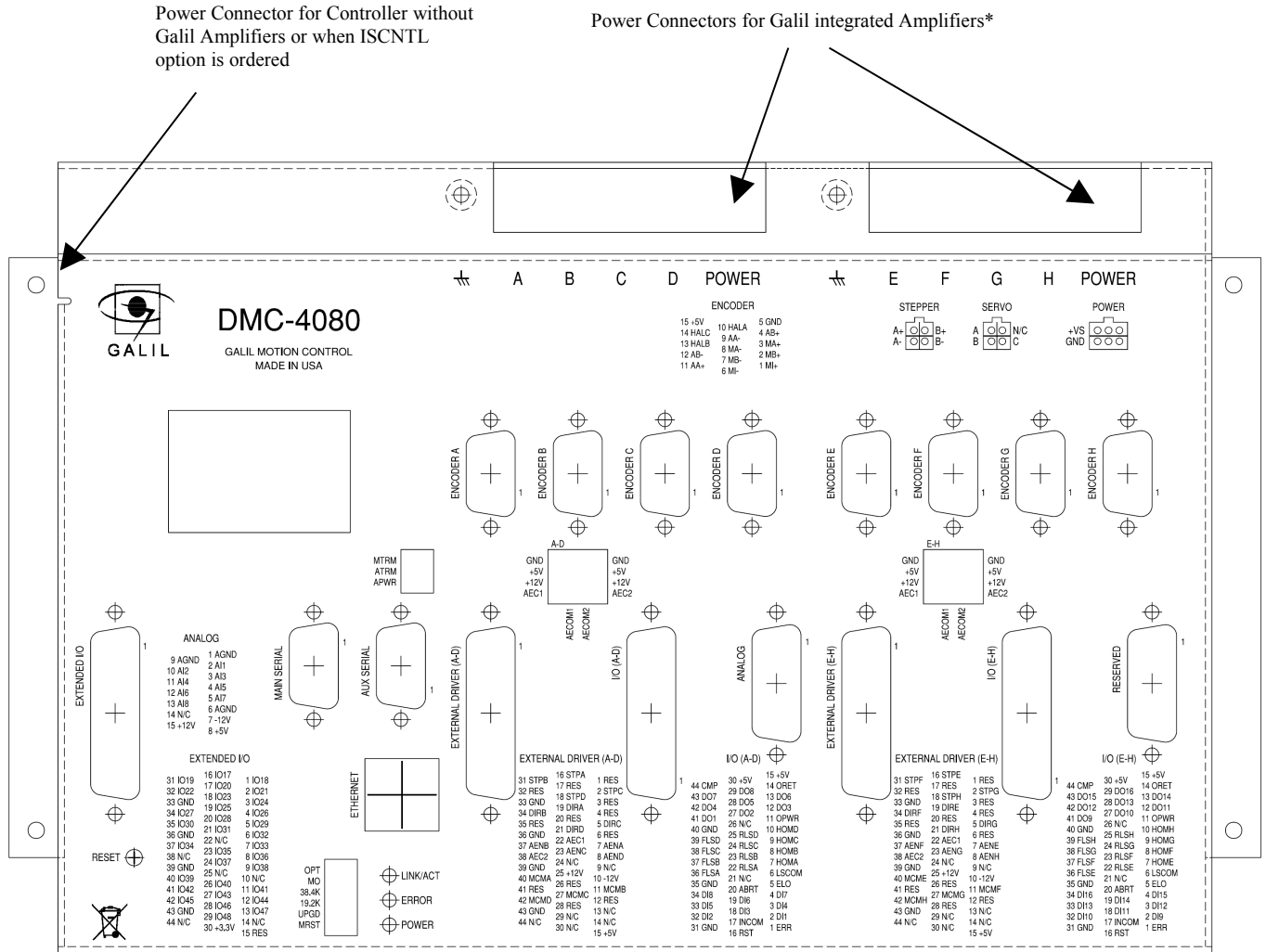

Figure 2-3 – Connector locations for the DMC-40x0

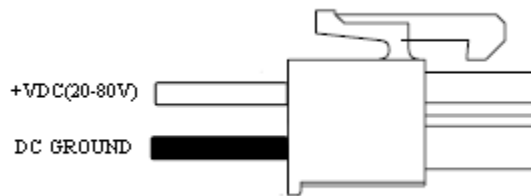

Figure 2-4 – Power Connector used when controller is ordered without Galil Amplifiers

*See Power connector information for specific amplifiers in the Integrated section of the Appendices.

For more information on Connectors (mfg PN's and diagrams) see the Power Connector Section in the Appendix.

DMC-4040 Dimensions

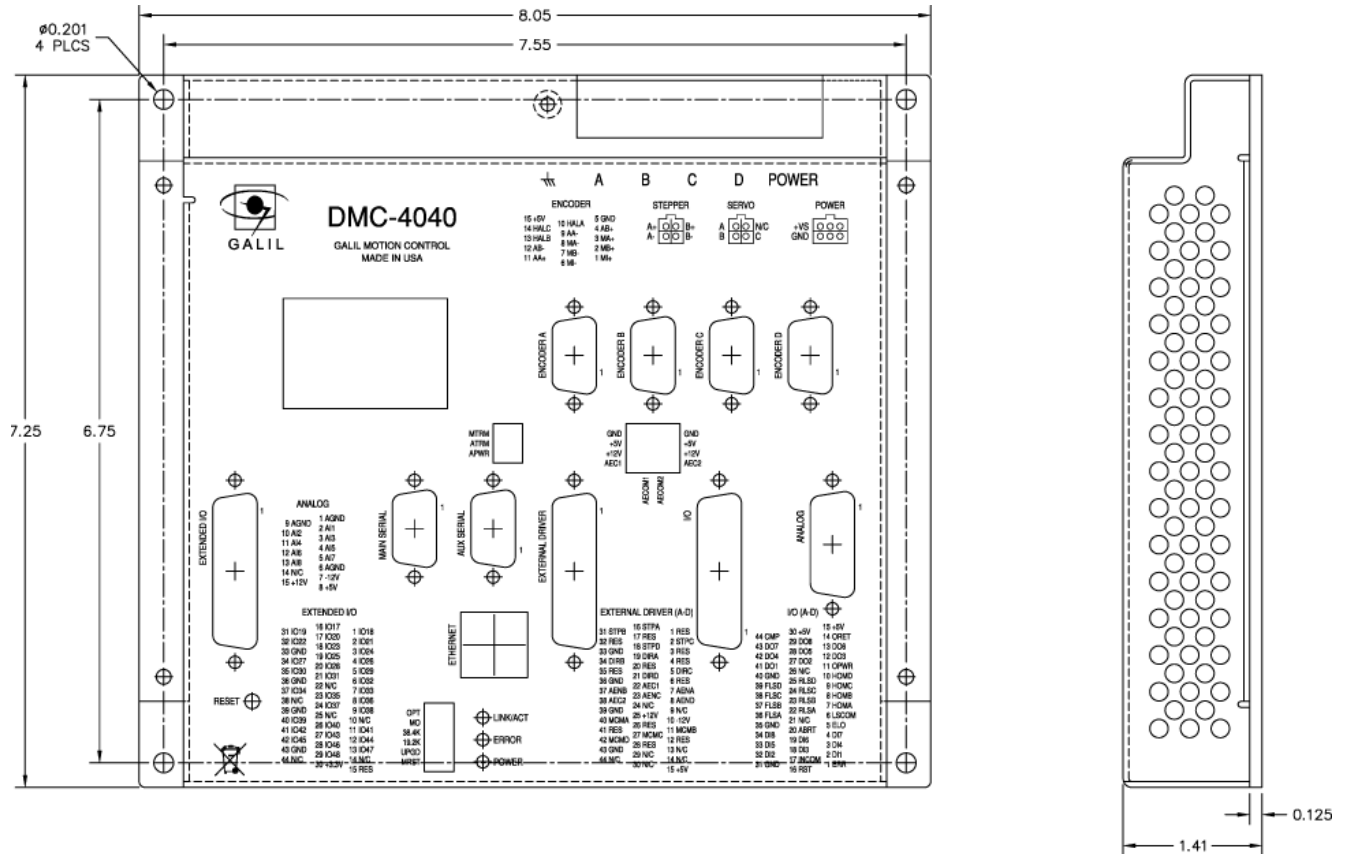

Figure 2-5 – Dimensions of DMC-4040

Elements You Need

For a complete system, Galil recommends the following elements:

1. DMC-4010, 4020, 4030, or DMC-4040 Motion Controller

or

DMC-4050, 4060, 4070 or DMC-4080

2. Motor Amplifiers (Integrated when using Galil amplifiers and drivers)
3. Power Supply for Amplifiers and controller
4. Brush or Brushless Servo motors with Optical Encoders or stepper motors.
 - a. Cables for connecting to the DMC-40x0's integrated ICM's.
5. PC (Personal Computer - RS232 or Ethernet for DMC-40x0)
6. GalilTools, or GalilTools-Lite Software package

GalilTools is highly recommended for first time users of the DMC-40x0. It provides step-by-step instructions for system connection, tuning and analysis.

Installing the DMC-40x0

Installation of a complete, operational DMC-40x0 system consists of 9 steps.

- Step 1.** Determine overall motor configuration.
- Step 2.** Install Jumpers on the DMC-40x0.
- Step 3.** Install the communications software.
- Step 4.** Connect DC power to controller.
- Step 5.** Establish communications with the Galil Communication Software.
- Step 6.** Determine the Axes to be used for sinusoidal commutation.
- Step 7.** Make connections to amplifier and encoder.
- Step 8a.** Connect standard servo motors.
- Step 8b.** Connect sinusoidal commutation motors
- Step 8c.** Connect step motors.
- Step 9.** Tune the servo system

Step 1. Determine Overall Motor Configuration

Before setting up the motion control system, the user must determine the desired motor configuration. The DMC-40x0 can control any combination of standard servo motors, sinusoidally commutated brushless motors, and stepper motors. Other types of actuators, such as hydraulics can also be controlled, please consult Galil.

The following configuration information is necessary to determine the proper motor configuration:

Standard Servo Motor Operation:

Unless ordered with stepper motor drivers or in a non-standard configuration, the DMC-40x0 has been setup by the factory for standard servo motor operation providing an analog command signal of +/- 10V. No hardware or software configuration is required for standard servo motor operation.

Sinusoidal Commutation:

Sinusoidal commutation is configured through a single software command, BA. This configuration causes the controller to reconfigure the number of available control axes.

Each sinusoidally commutated motor requires two DACs. In standard servo operation, the DMC-40x0 has one DAC per axis. In order to have the additional DAC for sinusoidal commutation, the controller must be designated as having one additional axis for each sinusoidal commutation axis. For example, to control two standard servo axes and one axis of sinusoidal commutation, the controller will require a total of four DACs and the controller must be a DMC-4040.

Sinusoidal commutation is configured with the command, BA. For example, BAA sets the A axis to be sinusoidally commutated. The second DAC for the sinusoidal signal will be the highest available DAC on the controller. For example: Using a DMC-4040, the command BAA will configure the A axis to be the main sinusoidal signal and the 'D' axis to be the second sinusoidal signal.

The BA command also reconfigures the controller to indicate that the controller has one less axis of 'standard' control for each axis of sinusoidal commutation. For example, if the command BAA is given to a DMC-4040 controller, the controller will be re-configured to a DMC-4030 controller. By definition, a DMC-4030 controls 3 axes: A,B and C. The 'D' axis is no longer available since the output DAC is being used for sinusoidal commutation.

Further instruction for sinusoidal commutation connections are discussed in Step 6.

Stepper Motor Operation

To configure the DMC-40x0 for stepper motor operation, the controller requires that the command, MT, must be given. Further instruction for stepper motor connections are discussed in Step 8c.

Step 2. Install Jumpers on the DMC-40x0

Master Reset and Upgrade Jumpers

JP1 on the main board contains two jumpers, MRST and UPGRD. The MRST jumper is the Master Reset jumper. When MRST is connected, the controller will perform a master reset upon PC power up or upon the reset input going low. Whenever the controller has a master reset, all programs, arrays, variables, and motion control parameters stored in EEPROM will be ERASED.

The UPGRD jumper enables the user to unconditionally update the controller's firmware. This jumper is not necessary for firmware updates when the controller is operating normally, but may be necessary in cases of corrupted EEPROM. EEPROM corruption should never occur, however, it is possible if there is a power fault during a firmware update. If EEPROM corruption occurs, your controller may not operate properly. In this case, install the UPGRD Jumper and use the update firmware function on the Galil Terminal to re-load the system firmware.

Motor Off Jumpers

The state of the motor upon power up may be selected with the placement of a hardware jumper on the controller. With a jumper installed at the MO location, the controller will be powered up in the "motor off" state. The SH command will need to be issued in order for the motor to be enabled. With no jumper installed, the controller will immediately enable the motor upon power up. The MO command will need to be issued to turn the motor off, unless an error occurs that will turn the motors off. The MO jumper is located on JP1, the same block as the Master Reset and Upgrade jumpers.

Communications Jumpers for DMC-40x0

The baud rate for RS232 communication can be set with jumpers found on JP1 of the communication board (same set of jumpers where MO, MRST and UPGD can be found). To set the baud rate to the desired value, see below.

19.2	38.4	BAUD RATE
ON	ON	9600
ON	OFF	19200
OFF	ON	38400
OFF	OFF	115200

Table 2-1 : Baud Rate Jumper Settings

Other serial communication protocols, such as RS-485, can be implemented as a special - consult Galil.

Step 3. Install the Communications Software

After applying power to the computer, you should install the Galil software that enables communication between the controller and PC.

Using Windows XP (32 & 64 bit):

Install the Galil Software Products CD-ROM into your CD drive. A Galil .htm page should automatically appear with links to the software products. Select the correct version of GalilTools software for your particular operating system and click "Install..." Follow the installation procedure as outlined.

The most recent copy of the GalilTools software can be downloaded from the Galil website.

<http://www.galilmc.com/products/software/galiltools.html>

All other Galil software is also available for download at the Galil software downloads page.

<http://www.galilmc.com/support/download.html>

Using Linux (32 & 64 bit):

The GalilTools software package is fully compatible with a number of Linux distributions. See the GalilTools webpage and user manual for downloads and installation instructions.

<http://www.galilmc.com/products/software/galiltools.html>

Step 4. Connect 20-80VDC Power to the Controller

If the controller was ordered with Galil Amplifiers or Drivers, then power to the controller will be supplied through those power connectors. Otherwise the power will come through the connector on the side of the controller. See DMC-40x0 Power Connections.

WARNING: Dangerous voltages, current, temperatures and energy levels exist in this product and the associated amplifiers and servo motor(s). Extreme caution should be exercised in the application of this equipment. Only qualified individuals should attempt to install, set up and operate this equipment. Never open the controller box when DC power is applied to it.

The green power light indicator should go on when power is applied.

Step 5. Establish Communications with Galil Software

Communicating through an Ethernet connection

The DMC-40x0 motion controller is equipped with DHCP. If the controller is connected to a DHCP enabled network, an IP address will automatically be assigned to the controller. See Ethernet Configuration in Chapter 4 for more information.

Using GalilTools Software for Windows

Registering controllers in the Windows registry is no longer required when using the GalilTools software package. A simple connection dialog box appears when the software is opened that shows all available controllers.

Any available controllers with assigned IP addresses can be found under the 'Available' tab in the Connections Dialog Box. If the controller is not connected to a DHCP enabled network, or the DH command is set to 0, and the controller has not been assigned an IP address, the controller can be found under the 'No IP Address' tab.

For more information on establishing communication to the controller via the GalilTools software, see the GalilTools user manual.

<http://www.galilmc.com/support/manuals/galiltools/index.html>

Using DMC-SmartTerminal or WSDK Software for Windows

NOTE: For new applications, Galil recommends using the GalilTools software package.

The controller must be registered in the Windows registry for the host computer to communicate with it. The registry may be accessed via Galil software, such as WSDK or GALIL Smart Terminal.

A dedicated network card with a static IP address is recommended. To set your NIC card to a static IP, go to the Control Panel → Network Connections → Local Area Connection → Properties → TCP/IP and choose "use the following IP address". If a "Dynamic" IP address is used, make sure there is a DHCP Server on your network or you will encounter an error.

Use the “**New Controller**” button to add a new entry in the registry or alternatively click on the “**Find Ethernet Controller**” to have the software search for controllers connected to the network. When adding a new controller, choose DMC-40x0 as the controller type. Enter the IP address obtained from your system administrator. Select the button corresponding to the UDP or TCP protocol in which you wish to communicate with the controller. If the IP address has not been already assigned to the controller, click on **ASSIGN IP ADDRESS**.

ASSIGN IP ADDRESS will check the controllers that are linked to the network to see which ones do not have an IP address. The program will then ask you whether you would like to assign the IP address you entered to the controller with the specified serial number. Click on **YES** to assign it, **NO** to move to next controller, or **CANCEL** to not save the changes. If there are no controllers on the network that do not have an IP address assigned, the program will state this.

When done registering, click on **OK**. If you do not wish to save the changes, click on **CANCEL**.

Once the controller has been registered, select the correct controller from the list and click on **OK**. If the software successfully established communications with the controller, the registry entry will be displayed at the bottom of the screen in the Status window.

NOTE: The controller must be registered via an Ethernet connection.

Communicating through the Main Serial Communications Port

Connect the DMC-40x0 MAIN serial port to your computer via the Galil CABLE-9PIN-D (RS-232 Cable). This is a straight through serial cable – **NOT** a NULL modem.

Using GalilTools Software for Windows

Registering controllers in the Windows registry is no longer required when using the GalilTools software package. A simple connection dialog box appears when the software is opened that shows all available controllers.

The serial ports are listed as COMn ‘communication speed’. (ex COM1 115200). The default serial communication speed on the DMC-40x0 is 115200Bps.

For more information on establishing communication to the controller via the GalilTools software, see the GalilTools user manual.

<http://www.galilmc.com/support/manuals/galiltools/index.html>

Using DMC-SmartTerminal or WSDK Software for Windows

NOTE: For new applications, Galil recommends using the GalilTools software package.

In order for the windows software to communicate with a Galil controller, the controller must be registered in the Windows Registry. To register a controller, you must specify the model of the controller, the communication parameters, and other information. The registry is accessed through the Galil software under the “File” menu in WSDK or under the “Tools” menu in the Galil Smart Terminal.

Use the “**New Controller**” button to add a new entry to the Registry. You will need to supply the Galil Controller model (eg: DMC-40x0). Pressing the down arrow to the right of this field will reveal a menu of valid controller types. You then need to choose serial or Ethernet connection. The registry information will show a default Comm. Port of 1 and a default Comm. Speed of 115200 appears. This information can be changed as necessary to reflect the computers Comm. Port and the baud rate set by the jumpers found on the communications board. The registry entry also displays timeout and delay information. These are advanced parameters which should only be modified by advanced users (see software documentation for more information).

Once you have set the appropriate Registry information for your controller, Select OK and close the registry window. You will now be able to communicate with the controller.

To establish communication to the controller, open up the Terminal and hit the “Enter” key. You should receive a colon prompt. Communicating with the controller is described in later sections.

If you are not properly communicating with the controller, the program will pause for 3-15 seconds and an error message will be displayed. In this case, there is most likely an incorrect setting of the serial communications port or the serial cable is not connected properly. The user must ensure that the correct communication port and baud rate are specified when attempting to communicate with the controller. Please note that the serial port on the controller must be set for handshake mode for proper communication with Galil software. The user must also insure that a “straight-through” serial cable is being used (**NOT** a Null Modem cable), see appendix for pin-out of serial cable.

Using Non-Galil Communication Software

The DMC-40x0 main serial port is configured as DATASET. Your computer or terminal must be configured as a DATATERM for full duplex, no parity, 8 data bits, one start bit and one stop bit.

Check to insure that the baud rate jumpers have been set to the desired baud rate as described above.

Your computer needs to be configured as a "dumb" terminal which sends ASCII characters as they are typed to the DMC-40x0.

Sending Test Commands to the Terminal:

After you connect your terminal, press <return> or the <enter> key on your keyboard. In response to carriage return <return>, the controller responds with a colon, :

Now type

```
TPA <return>
```

This command directs the controller to return the current position of the A axis. The controller should respond with a number such as

```
:0
```

Step 6. Determine the Axes to be Used for Sinusoidal Commutation

* This step is only required when the controller will be used to control a brushless motor(s) with sinusoidal commutation.

The command, BA is used to select the axes of sinusoidal commutation. For example, BAAC sets A and C as axes with sinusoidal commutation.

Notes on Configuring Sinusoidal Commutation:

The command, BA, reconfigures the controller such that it has one less axis of 'standard' control for each axis of sinusoidal commutation. For example, if the command BAA is given to a DMC-4040 controller, the controller will be re-configured to be a DMC-4030 controller. In this case the highest axis is no longer available except to be used for the 2nd phase of the sinusoidal commutation. Note that the highest axis on a controller can never be configured for sinusoidal commutation.

The DAC associated with the selected axis represents the first phase. The second phase uses the highest available DAC. When more than one axis is configured for sinusoidal commutation, the controller will assign the second phases to the DACs which have been made available through the axes reconfiguration. The highest sinusoidal commutation axis will be assigned to the highest available DAC and the lowest sinusoidal commutation axis will be assigned to the lowest available DAC. Note that the lowest axis is the A axis and the highest axis is the highest available axis for which the controller has been configured.

Example: Sinusoidal Commutation Configuration using a DMC-4070

```
BAAC
```

This command causes the controller to be reconfigured as a DMC-4050 controller. The A and C axes are configured for sinusoidal commutation. The first phase of the A axis will be the motor command A signal. The second phase

of the A axis will be F signal. The first phase of the C axis will be the motor command C signal. The second phase of the C axis will be the motor command G signal.

Step 7. Make Connections to Amplifier and Encoder.

If the system is run solely by Galil's integrated amplifiers or drivers, skip this section, the amplifier is already connected to the controller.

Once you have established communications between the software and the DMC-40x0, you are ready to connect the rest of the motion control system. The motion control system typically consists of the controller with interconnect module, an amplifier for each axis of motion, and a motor to transform the current from the amplifier into torque for motion.

System connection procedures will depend on system components and motor types. Any combination of motor types can be used with the DMC-40x0. There can also be a combination of axes running from Galil integrated amplifiers and drivers and external amplifiers or drivers. If sinusoidal commutation is to be used, special attention must be paid to the reconfiguration of axes (see above section for more information).

Connecting to External Amplifiers

Here are the first steps for connecting a motion control system:

Step A. Connect the motor to the amplifier *with no connection to the controller*. Consult the amplifier documentation for instructions regarding proper connections. Connect and turn-on the amplifier power supply. If the amplifiers are operating properly, the motor should stand still even when the amplifiers are powered up.

Step B. Connect the amplifier enable signal.

Before making any connections from the amplifier to the controller, you need to verify that the ground level of the amplifier is either floating or at the same potential as earth.

WARNING: When the amplifier ground is not isolated from the power line or when it has a different potential than that of the computer ground, serious damage may result to the computer controller and amplifier.

If you are not sure about the potential of the ground levels, connect the two ground signals (amplifier ground and earth) by a 10 k Ω resistor and measure the voltage across the resistor. Only if the voltage is zero, connect the two ground signals directly.

The amplifier enable signal is used by the controller to disable the motor. When configured with the ICM-42000 or ICM-42100, this signal is labeled AENA for the A axis and is found on the 15 pin Dsub connector associated with the A axis (if configured with the ICM-42200 the AENA signal is located on the 26 pin Dsub associated with the A axis). Note that many amplifiers designate this signal as the INHIBIT signal. Use the command, MO, to disable the motor amplifiers - check to insure that the motor amplifiers have been disabled (often this is indicated by an LED on the amplifier).

This signal changes under the following conditions: the watchdog timer activates, the motor-off command, MO, is given, or the OE3 command (Enable Off-On-Error) is given and the position error exceeds the error limit. AMPEN can be used to disable the amplifier for these conditions.

The AMPEN signal from the DMC-40x0 is shipped as a default of 5V active high or high amp enable. In other words, the AMPEN signal will be high when the controller expects the amplifier to be enabled.

If your amplifier requires a different configuration it is highly recommended that the DMC-40x0 is ordered with the desired configuration. See the DMC-40x0 ordering information in the catalog (<http://www.galilmc.com/catalog/cat40x0.pdf>) or contact Galil for more information on ordering different configurations. If the amplifier enable needs to be changed, see the ICM-42000 and ICM-42100 Amplifier Enable Circuit section in Chapter 3 Connecting Hardware.

When ordered with ICM-42000's or ICM-42100's the AEN signal is configurable for axes 1-4 and axes 5-8. Ex – axes 1-4 could be ordered as 5V high amp enable, and axes 5-8 could be ordered as 12V low amp enable. When ordered with ICM-42200's each axis is individually configurable.

Step C. Connect the encoders

For stepper motor operation, an encoder is optional.

For servo motor operation, if you have a preferred definition of the forward and reverse directions, make sure that the encoder wiring is consistent with that definition.

The DMC-40x0 accepts single-ended or differential encoder feedback with or without an index pulse. The encoder signals are wired to that axis associated 15pin DSub connector found on top of the controller. The signal leads are labeled MA+ (channel A), MB+ (channel B), and MI+. For differential encoders, the complement signals are labeled MA-, MB-, and MI-. For complete pin-out information see in the Appendices.

NOTE: When using pulse and direction encoders, the pulse signal is connected to CHA and the direction signal is connected to CHB. The controller must be configured for pulse and direction with the command CE. See the command summary for further information on the command CE.

Step D. Verify proper encoder operation.

Start with the A encoder first. Once it is connected, turn the motor shaft and interrogate the position with the instruction TPA <return>. The controller response will vary as the motor is turned.

At this point, if TPA does not vary with encoder rotation, there are three possibilities:

1. The encoder connections are incorrect - check the wiring as necessary.
2. The encoder has failed - using an oscilloscope, observe the encoder signals. Verify that both channels A and B have a peak magnitude between 5 and 12 volts. Note that if only one encoder channel fails, the position reporting varies by one count only. If the encoder failed, replace the encoder. If you cannot observe the encoder signals, try a different encoder.
3. There is a hardware failure in the controller - connect the same encoder to a different axis. If the problem disappears, you may have a hardware failure. Consult the factory for help.

Step E. Connect Hall Sensors if available.

Hall sensors are only used with sinusoidal commutation and are not necessary for proper operation. The use of Hall sensors allows the controller to automatically estimate the commutation phase upon reset and also provides the controller the ability to set a more precise commutation phase. Without Hall sensors, the commutation phase must be determined manually.

The Hall Effect sensors are connected to the digital inputs of the controller. These inputs can be used with the general use inputs (bits 1-8), the auxiliary encoder inputs (bits 81-96), or the extended I/O inputs of the DMC-40x0 controller (bits 17-80).

NOTE: The general use inputs are optoisolated and require a voltage connection at the INCOM point - for more information regarding the digital inputs, see Chapter 3, Connecting Hardware.

Each set of sensors must use inputs that are in consecutive order. The input lines are specified with the command, BI. For example, if the Hall sensors of the C axis are connected to inputs 6, 7 and 8, use the instruction:

```
BI ,, 6 or
```

```
BIC = 6
```

Step 8a. Connect Standard Servo Motors

The following discussion applies to connecting the DMC-40x0 controller to standard servo motors:

The motor and the amplifier may be configured in the torque or the velocity mode. In the torque mode, the amplifier gain should be such that a 10 volt signal generates the maximum required current. In the velocity mode, a command signal of 10 volts should run the motor at the maximum required speed. For Galil amplifiers, see Integrated .

Step A. Check the Polarity of the Feedback Loop

It is assumed that the motor and amplifier are connected together and that the encoder is operating correct (Step 7). Before connecting the motor amplifiers to the controller, read the following discussion on setting Error Limits and Torque Limits. Note that this discussion only uses the A axis as an examples.

Step B. Set the Error Limit as a Safety Precaution

Usually, there is uncertainty about the correct polarity of the feedback. The wrong polarity causes the motor to run away from the starting position. Using a terminal program, such as Galil Tools, the following parameters can be given to avoid system damage:

Input the commands:

```
ER 2000 <return>    Sets error limit on the A axis to be 2000 encoder counts
```

```
OE 1 <return>    Disables A axis amplifier when excess position error exists
```

If the motor runs away and creates a position error of 2000 counts, the motor amplifier will be disabled.

NOTE: This function requires the AMPEN signal to be connected from the controller to the amplifier.

Step C. Set Torque Limit as a Safety Precaution

To limit the maximum voltage signal to your amplifier, the DMC-40x0 controller has a torque limit command, TL. This command sets the maximum voltage output of the controller and can be used to avoid excessive torque or speed when initially setting up a servo system.

When operating an amplifier in torque mode, the voltage output of the controller will be directly related to the torque output of the motor. The user is responsible for determining this relationship using the documentation of the motor and amplifier. The torque limit can be set to a value that will limit the motors output torque.

When operating an amplifier in velocity or voltage mode, the voltage output of the controller will be directly related to the velocity of the motor. The user is responsible for determining this relationship using the documentation of the motor and amplifier. The torque limit can be set to a value that will limit the speed of the motor.

For example, the following command will limit the output of the controller to 1 volt on the X axis:

```
TL 1 <return>
```

NOTE: Once the correct polarity of the feedback loop has been determined, the torque limit should, in general, be increased to the default value of 9.99. The servo will not operate properly if the torque limit is below the normal operating range. See description of TL in the command reference.

Step D. Connect the Motor

Once the parameters have been set, connect the analog motor command signal (MCM n where n is A-H) to the amplifier input.

To test the polarity of the feedback, command a move with the instruction:

```
PR 1000 <CR>    Position relative 1000 counts
```

```
BGA <CR>    Begin motion on A axis
```

When the polarity of the feedback is wrong, the motor will attempt to run away. The controller should disable the motor when the position error exceeds 2000 counts. If the motor runs away, the polarity of the loop must be inverted.

Inverting the Loop Polarity

When the polarity of the feedback is incorrect, the user must invert the loop polarity and this may be accomplished by several methods. If you are driving a brush-type DC motor, the simplest way is to invert the two motor wires (typically red and black). For example, switch the M1 and M2 connections going from your amplifier to the motor. When driving a brushless motor, the polarity reversal may be done with the encoder. If you are using a single-ended encoder, interchange the signal MA+ and MB+. If, on the other hand, you are using a differential encoder, interchange only MA+ and MA-. The loop polarity and encoder polarity can also be affected through software with the MT, and CE commands. For more details on the MT command or the CE command, see the Command Reference section.

To Invert Polarity using Hall-Commutated brushless motors, invert motor phases B & C, exchange Hall A with Hall B, and invert encoder polarity as described above.

Sometimes the feedback polarity is correct (the motor does not attempt to run away) but the direction of motion is reversed with respect to the commanded motion. If this is the case, reverse the motor leads AND the encoder signals.

If the motor moves in the required direction but stops short of the target, it is most likely due to insufficient torque output from the motor command signal MCM n . This can be alleviated by reducing system friction on the motors. The instruction:

```
TTA <return> Tell torque on A
```

reports the level of the output signal. It will show a non-zero value that is below the friction level.

Once you have established that you have closed the loop with the correct polarity, you can move on to the compensation phase (servo system tuning) to adjust the PID filter parameters, KP, KD and KI. It is necessary to accurately tune your servo system to ensure fidelity of position and minimize motion oscillation as described in the next section.

Step 8b. Connect Sinusoidal Commutation Motors

When using sinusoidal commutation, the parameters for the commutation must be determined and saved in the controller's non-volatile memory. The setup for sinusoidal commutation is different when using Hall Sensors. Each step which is affected by Hall Sensor Operation is divided into two parts, part 1 and part 2. After connecting sinusoidal commutation motors, the servos must be tuned as described in Step 9.

Step A. Disable the motor amplifier

Use the command, MO, to disable the motor amplifiers. For example, MOA will turn the A axis motor off.

Step B. Connect the motor amplifier to the controller.

The sinusoidal commutation amplifier requires 2 signals, usually denoted as Phase A & Phase B. These inputs should be connected to the two sinusoidal signals generated by the controller. The first signal is the axis specified with the command, BA (Step 6). The second signal is associated with the highest analog command signal available on the controller - note that this axis was made unavailable for standard servo operation by the command BA.

When more than one axis is configured for sinusoidal commutation, the controller will assign the second phase to the command output which has been made available through the axes reconfiguration. The 2nd phase of the highest sinusoidal commutation axis will be the highest command output and the 2nd phase of the lowest sinusoidal commutation axis will be the lowest command output.

It is not necessary to be concerned with cross-wiring the 1st and 2nd signals. If this wiring is incorrect, the setup procedure will alert the user (Step D).

Example: Sinusoidal Commutation Configuration using a DMC-4070

```
BAAC
```

This command causes the controller to be reconfigured as a DMC-4050 controller. The A and C axes are configured for sinusoidal commutation. The first phase of the A axis will be the motor command A signal. The second phase of the A axis will be the motor command F signal. The first phase of the C axis will be the motor command C signal. The second phase of the C axis will be the motor command G signal.

Step C. Specify the Size of the Magnetic Cycle.

Use the command, BM, to specify the size of the brushless motors magnetic cycle in encoder counts. For example, if the X axis is a linear motor where the magnetic cycle length is 62 mm, and the encoder resolution is 1 micron, the cycle equals 62,000 counts. This can be commanded with the command:

```
BM 62000
```

On the other hand, if the C axis is a rotary motor with 4000 counts per revolution and 3 magnetic cycles per revolution (three pole pairs) the command is:

```
BM, , 1333.333
```

Step D - part 1 (Systems with or without Hall Sensors). Test the Polarity of the DACs

Use the brushless motor setup command, BS, to test the polarity of the output DACs. This command applies a certain voltage, V, to each phase for some time T, and checks to see if the motion is in the correct direction.

The user must specify the value for V and T. For example, the command:

```
BSA = 2,700
```

will test the A axis with a voltage of 2 volts, applying it for 700 millisecond for each phase. In response, this test indicates whether the DAC wiring is correct and will indicate an approximate value of BM. If the wiring is correct, the approximate value for BM will agree with the value used in the previous step.

NOTE: In order to properly conduct the brushless setup, the motor must be allowed to move a minimum of one magnetic cycle in both directions.

NOTE: When using Galil Windows software, the timeout must be set to a minimum of 10 seconds (time-out = 10000) when executing the BS command. This allows the software to retrieve all messages returned from the controller.

Step D - part 2 (Systems with Hall Sensors Only). Test the Hall Sensor Configuration.

Since the Hall sensors are connected randomly, it is very likely that they are wired in the incorrect order. The brushless setup command indicates the correct wiring of the Hall sensors. The Hall sensor wires should be re-configured to reflect the results of this test.

The setup command also reports the position offset of the Hall transition point and the zero phase of the motor commutation. The zero transition of the Hall sensors typically occur at 0°, 30° or 90° of the phase commutation. It is necessary to inform the controller about the offset of the Hall sensor and this is done with the instruction, BB.

Step E. Save Brushless Motor Configuration

It is very important to save the brushless motor configuration in non-volatile memory. After the motor wiring and setup parameters have been properly configured, the burn command, BN, should be given.

NOTE: Without Hall sensors, the controller will not be able to estimate the commutation phase of the brushless motor. In this case, the controller could become unstable until the commutation phase has been set using the BZ command (see next step). It is highly recommended that the motor off command be given before executing the BN command. In this case, the motor will be disabled upon power up or reset and the commutation phase can be set before enabling the motor.

Step F - part 1 (Systems with or without Hall Sensors). Set Zero Commutation Phase

When an axis has been defined as sinusoidally commutated, the controller must have an estimate for commutation phase. When Hall sensors are used, the controller automatically estimates this value upon

reset of the controller. If no Hall sensors are used, the controller will not be able to make this estimate and the commutation phase must be set before enabling the motor.

To initialize the commutation without Hall effect sensor use the command, BZ. This function drives the motor to a position where the commutation phase is zero, and sets the phase to zero.

The BZ command is followed by real numbers in the fields corresponding to the driven axes. The number represents the voltage to be applied to the amplifier during the initialization. When the voltage is specified by a positive number, the initialization process ends up in the motor off (MO) state. A negative number causes the process to end in the Servo Here (SH) state.

WARNING: This command must move the motor to find the zero commutation phase. This movement is instantaneous and will cause the system to jerk. Larger applied voltages will cause more severe motor jerk. The applied voltage will typically be sufficient for proper operation of the BZ command. For systems with significant friction, this voltage may need to be increased and for systems with very small motors, this value should be decreased. For example:

BZ -2, 0,1

will drive both A and C axes to zero, will apply 2V and 1V respectively to A and C and will end up with A in SH and C in MO.

Step F - part 2 (Systems with Hall Sensors Only). Set Zero Commutation Phase

With Hall sensors, the estimated value of the commutation phase is good to within 30°. This estimate can be used to drive the motor but a more accurate estimate is needed for efficient motor operation. There are 3 possible methods for commutation phase initialization:

Method 1. Use the BZ command as described above.

Method 2. Drive the motor close to commutation phase of zero and then use BZ command. This method decreases the amount of system jerk by moving the motor close to zero commutation phase before executing the BZ command. The controller makes an estimate for the number of encoder counts between the current position and the position of zero commutation phase. This value is stored in the operand `_BZn`. Using this operand the controller can be commanded to move the motor. The BZ command is then issued as described above. For example, to initialize the A axis motor upon power or reset, the following commands may be given:

```
SHA           ;Enable A axis motor
PRA=-1*(_BZA) ;Move A motor close to zero commutation phase
BGA           ;Begin motion on A axis
AMA           ;Wait for motion to complete on A axis
BZA=-1        ;Drive motor to commutation phase zero and leave motor on
```

Method 3. Use the command, BC. This command uses the Hall transitions to determine the commutation phase. Ideally, the Hall sensor transitions will be separated by exactly 60° and any deviation from 60° will affect the accuracy of this method. If the Hall sensors are accurate, this method is recommended. The BC command monitors the Hall sensors during a move and monitors the Hall sensors for a transition point. When that occurs, the controller computes the commutation phase and sets it. For example, to initialize the A axis motor upon power or reset, the following commands may be given:

```
SHA           ;Enable A axis motor
BCA           ;Enable the brushless calibration command
PRA=50000     ;Command a relative position movement on A axis
BGA           ;Begin motion on A axis. When the Hall sensors detect a
              ;phase transition, the commutation phase is reset
```



Step 8c. Connect Step Motors

In Stepper Motor operation, the pulse output signal has a 50% duty cycle. Step motors operate open loop and do not require encoder feedback. When a stepper is used, the auxiliary encoder for the corresponding axis is unavailable for an external connection. If an encoder is used for position feedback, connect the encoder to the main encoder input corresponding to that axis. The commanded position of the stepper can be interrogated with RP or TD. The encoder position can be interrogated with TP.

If encoders are available on the stepper motor, Galil's Stepper Position Maintenance Mode may be used for automatic monitoring and correction of the stepper position. See Stepper Position Maintenance Mode (SPM) in Chapter 6 Programming Motion for more information.

The frequency of the step motor pulses can be smoothed with the filter parameter, KS. The KS parameter has a range between 0.25 and 64, where 64 implies the largest amount of smoothing. *See Command Reference regarding KS.*

The DMC-40x0 profiler commands the step motor amplifier. All DMC-40x0 motion commands apply such as PR, PA, VP, CR and JG. The acceleration, deceleration, slew speed and smoothing are also used. Since step motors run open-loop, the PID filter does not function and the position error is not generated.

To connect step motors with the DMC-40x0 you must follow this procedure – If you have a Galil integrated stepper driver skip Step A, the step and direction lines are already connected to the driver:

Step A. Connect step and direction signals from controller to motor amplifier

From the controller to respective signals on your step motor amplifier. (These signals are labeled STPA and DIRA for the A-axis on the EXTERNAL DRIVER (A-D) D-Sub connector top of the controller). Consult the documentation for connecting these signals to your step motor amplifier.

Step B. Configure DMC-40x0 for motor type using MT command. You can configure the DMC-40x0 for active high or active low pulses. Use the command MT 2 or 2.5 for active low step motor pulses and MT -2 or -2.5 for active high step motor pulses. *See description of the MT command in the Command Reference.*

Step 9. Tune the Servo System

Adjusting the tuning parameters is required when using servo motors (standard or sinusoidal commutation). The system compensation provides fast and accurate response and the following section suggests a simple and easy way for compensation. More advanced design methods are available with software design tools from Galil, such as the GalilTools.

The filter has three parameters: the damping, KD; the proportional gain, KP; and the integrator, KI. The parameters should be selected in this order.

To start, set the integrator to zero with the instruction

```
KI 0 <return>      Integrator gain
```

and set the proportional gain to a low value, such as

```
KP 1 <return>      Proportional gain
```

```
KD 100 <return>    Derivative gain
```

For more damping, you can increase KD (maximum is 4095.875). Increase gradually and stop after the motor vibrates. A vibration is noticed by audible sound or by interrogation. If you send the command

```
TE A <return>      Tell error
```

a few times, and get varying responses, especially with reversing polarity, it indicates system vibration. When this happens, simply reduce KD by about 20%.

Next you need to increase the value of KP gradually (maximum allowed is 1023.875). You can monitor the improvement in the response with the Tell Error instruction

```
KP 10 <return>    Proportion gain
TE A <return>     Tell error
```

As the proportional gain is increased, the error decreases.

Again, the system may vibrate if the gain is too high. In this case, reduce KP by about 20%. Typically, KP should not be greater than KD/4 (only when the amplifier is configured in the current mode).

Finally, to select KI, start with zero value and increase it gradually. The integrator eliminates the position error, resulting in improved accuracy. Therefore, the response to the instruction

```
TE A <return>
```

becomes zero. As KI is increased, its effect is amplified and it may lead to vibrations. If this occurs, simply reduce KI. Repeat tuning for the B, C and D axes.

Note: For a more detailed description of the operation of the PID filter and/or servo system theory, see **Chapter 10 Theory of Operation**

Design Examples

Here are a few examples for tuning and using your controller. These examples have remarks next to each command - these remarks must not be included in the actual program.

Example 1 - System Set-up

This example assigns the system filter parameters, error limits and enables the automatic error shut-off.

Instruction	Interpretation
KP10,10,10,10	Set gains for a,b,c,d (or A,B,C,D axes)
KP*=10	Alternate method for setting gain on all axes
KPA=10	Method for setting only A (or X) axis gain
KPX=10	Method for setting only X (or A) axis gain
KP, 20	Set B axis gain only
Instruction	Interpretation
OE 1,1,1,1,1,1,1,1	Enable automatic Off on Error function for all axes
ER*=1000	Set error limit for all axes to 1000 counts
KP10,10,10,10,10,10,10,10	Set gains for a,b,c,d,e,f,g,and h axes
KP*=10	Alternate method for setting gain on all axes
KPA=10	Alternate method for setting A axis gain
KP,,10	Set C axis gain only
KPD=10	Alternate method for setting D axis gain
KPH=10	Alternate method for setting H axis gain

Example 2 - Profiled Move

Rotate the A axis a distance of 10,000 counts at a slew speed of 20,000 counts/sec and an acceleration and deceleration rates of 100,000 counts/s². In this example, the motor turns and stops:

Instruction	Interpretation
PR1000	Distance

SP20000	Speed
DC 100000	Deceleration
AC 100000	Acceleration
BG A	Start Motion

Example 3 - Multiple Axes

Objective: Move the four axes independently.

Instruction	Interpretation
PR 500,1000,600,-400	Distances of A,B,C,D
SP 10000,12000,20000,10000	Slew speeds of A,B,C,D
AC 10000,10000,10000,10000	Accelerations of A,B,C,D
DC 80000,40000,30000,50000	Decelerations of A,B,C,D
BG AC	Start A and C motion
BG BD	Start B and D motion

Example 4 - Independent Moves

The motion parameters may be specified independently as illustrated below.

Instruction	Interpretation
PR ,300,-600	Distances of B and C
SP ,2000	Slew speed of B
DC ,80000	Deceleration of B
AC ,100000	Acceleration of B
AC ,,100000	Acceleration of C
DC,,150000	Deceleration of C
BG C	Start C motion
BG B	Start B motion

Example 5 - Position Interrogation

The position of the four axes may be interrogated with the instruction, TP.

Instruction	Interpretation
TP	Tell position all four axes
TP A	Tell position - A axis only
TP B	Tell position - B axis only
TP C	Tell position - C axis only
TP D	Tell position - D axis only

The position error, which is the difference between the commanded position and the actual position can be interrogated with the instruction TE.

Instruction	Interpretation
TE	Tell error - all axes
TE A	Tell error - A axis only
TE B	Tell error - B axis only
TE C	Tell error - C axis only
TE D	Tell error - D axis only

Example 6 - Absolute Position

Objective: Command motion by specifying the absolute position.

Instruction	Interpretation
-------------	----------------

DP 0,2000	Define the current positions of A,B as 0 and 2000
PA 7000,4000	Sets the desired absolute positions
BG A	Start A motion
BG B	Start B motion

After both motions are complete, the A and B axes can be command back to zero:

PA 0,0	Move to 0,0
BG AB	Start both motions

Example 7 - Velocity Control

Objective: Drive the A and B motors at specified speeds.

Instruction	Interpretation
JG 10000,-20000	Set Jog Speeds and Directions
AC 100000, 40000	Set accelerations
DC 50000,50000	Set decelerations
BG AB	Start motion

after a few seconds, command:

JG -40000	New A speed and Direction
TV A	Returns A speed

and then

JG ,20000	New B speed
TV B	Returns B speed

These cause velocity changes including direction reversal. The motion can be stopped with the instruction

ST	Stop
----	------

Example 8 - Operation Under Torque Limit

The magnitude of the motor command may be limited independently by the instruction TL.

Instruction	Interpretation
TL 0.2	Set output limit of A axis to 0.2 volts
JG 10000	Set A speed
BG A	Start A motion

In this example, the A motor will probably not move since the output signal will not be sufficient to overcome the friction. If the motion starts, it can be stopped easily by a touch of a finger.

Increase the torque level gradually by instructions such as

Instruction	Interpretation
TL 1.0	Increase torque limit to 1 volt.
TL 9.998	Increase torque limit to maximum, 9.998 volts.

The maximum level of 9.998 volts provides the full output torque.

Example 9 - Interrogation

The values of the parameters may be interrogated. Some examples ...

Instruction	Interpretation
-------------	----------------

KP?	Return gain of A axis
KP ,,?	Return gain of C axis.
KP ?,?,?/?	Return gains of all axes.

Many other parameters such as KI, KD, FA, can also be interrogated. The command reference denotes all commands which can be interrogated.

Example 10 - Operation in the Buffer Mode

The instructions may be buffered before execution as shown below.

Instruction	Interpretation
PR 600000	Distance
SP 10000	Speed
WT 10000	Wait 10000 milliseconds before reading the next instruction
BG A	Start the motion

Example 11 - Using the On-Board Editor

Motion programs may be edited and stored in the controller's on-board memory. When the command, ED is given from the Galil DOS terminal (such as DMCTERM), the controllers editor will be started.

The instruction

ED	Edit mode
----	-----------

moves the operation to the editor mode where the program may be written and edited. The editor provides the line number. For example, in response to the first ED command, the first line is zero.

Line #	Instruction	Interpretation
000	#A	Define label
001	PR 700	Distance
002	SP 2000	Speed
003	BGA	Start A motion
004	EN	End program

To exit the editor mode, input <cntrl>Q. The program may be executed with the command.

XQ #A	Start the program running
-------	---------------------------

If the ED command is issued from the Galil Windows terminal software (such as SmartTERM), the software will open a Windows based editor. From this editor a program can be entered, edited, downloaded and uploaded to the controller.

Example 12 - Motion Programs with Loops

Motion programs may include conditional jumps as shown below.

Instruction	Interpretation
#A	Label
DP 0	Define current position as zero
V1=1000	Set initial value of V1
#LOOP	Label for loop
PA V1	Move A motor V1 counts
BG A	Start A motion
AM A	After A motion is complete

WT 500	Wait 500 ms
TP A	Tell position A
V1=V1+1000	Increase the value of V1
JP #LOOP,V1<10001	Repeat if V1<10001
EN	End

After the above program is entered, quit the Editor Mode, <ctrl>Q. To start the motion, command:

XQ #A	Execute Program #A
-------	--------------------

Example 13 - Motion Programs with Trippoints

The motion programs may include trippoints as shown below.

Instruction	Interpretation
#B	Label
DP 0,0	Define initial positions
PR 30000,60000	Set targets
SP 5000,5000	Set speeds
BGA	Start A motion
AD 4000	Wait until A moved 4000
BGB	Start B motion
AP 6000	Wait until position A=6000
SP 2000,50000	Change speeds
AP ,50000	Wait until position B=50000
SP ,10000	Change speed of B
EN	End program

To start the program, command:

XQ #B	Execute Program #B
-------	--------------------

Example 14 - Control Variables

Objective: To show how control variables may be utilized.

Instruction	Interpretation
#A;DP0	Label; Define current position as zero
PR 4000	Initial position
SP 2000	Set speed
BGA	Move A
AMA	Wait until move is complete
WT 500	Wait 500 ms
#B	
V1 = _TPA	Determine distance to zero
PR -V1/2	Command A move 1/2 the distance
BGA	Start A motion
AMA	After A moved
WT 500	Wait 500 ms
V1=	Report the value of V1
JP #C, V1=0	Exit if position=0
JP #B	Repeat otherwise
#C	Label #C

EN End of Program

To start the program, command

XQ #A Execute Program #A

This program moves A to an initial position of 1000 and returns it to zero on increments of half the distance. Note, `_TPA` is an internal variable which returns the value of the A position. Internal variables may be created by preceding a DMC-40x0 instruction with an underscore, `_`.

Example 15 - Linear Interpolation

Objective: Move A,B,C motors distance of 7000,3000,6000, respectively, along linear trajectory. Namely, motors start and stop together.

Instruction	Interpretation
LM ABC	Specify linear interpolation axes
LI 7000,3000,6000	Relative distances for linear interpolation
LE	Linear End
VS 6000	Vector speed
VA 20000	Vector acceleration
VD 20000	Vector deceleration
BGS	Start motion

Example 16 - Circular Interpolation

Objective: Move the AB axes in circular mode to form the path shown on Fig. 2-8. Note that the vector motion starts at a local position (0,0) which is defined at the beginning of any vector motion sequence. See application programming for further information.

Instruction	Interpretation
VM AB	Select AB axes for circular interpolation
VP -4000,0	Linear segment
CR 2000,270,-180	Circular segment
VP 0,4000	Linear segment
CR 2000,90,-180	Circular segment
VS 1000	Vector speed
VA 50000	Vector acceleration
VD 50000	Vector deceleration
VE	End vector sequence
BGS	Start motion

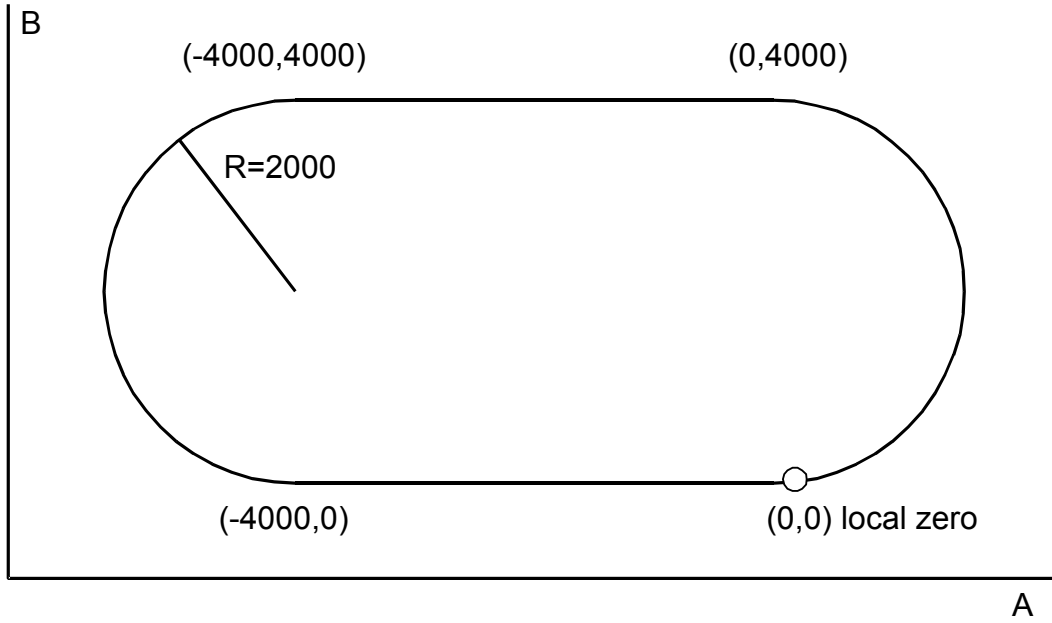

Figure 2-7 Motion Path for Circular Interpolation Example

Chapter 3 Connecting Hardware

Overview

The DMC-40x0 provides opto-isolated digital inputs for **forward limit**, **reverse limit**, **home**, and **abort** signals. The controller also has **8 opto-isolated, uncommitted inputs** (for general use) as well as **8 high power opto-isolated outputs** and **8 analog inputs** configured for voltages between +/- 10 volts.

4080

Controllers with 5 or more axes have an additional 8 opto-isolated inputs and an additional 8 high power opto-isolated outputs.

This chapter describes the inputs and outputs and their proper connection.

Using Optoisolated Inputs

Limit Switch Input

The forward limit switch (FLSx) inhibits motion in the forward direction immediately upon activation of the switch. The reverse limit switch (RLSx) inhibits motion in the reverse direction immediately upon activation of the switch. If a limit switch is activated during motion, the controller will make a decelerated stop using the deceleration rate previously set with the SD command. The motor will remain on (in a servo state) after the limit switch has been activated and will hold motor position.

When a forward or reverse limit switch is activated, the current application program that is running in thread zero will be interrupted and the controller will automatically jump to the #LIMSWI subroutine if one exists. This is a subroutine which the user can include in any motion control program and is useful for executing specific instructions upon activation of a limit switch. Automatic Subroutines for Monitoring Conditions are discussed in Chapter 7 Application Programming.

After a limit switch has been activated, further motion in the direction of the limit switch will not be possible until the logic state of the switch returns back to an inactive state. This usually involves physically opening the tripped switch. Any attempt at further motion before the logic state has been reset will result in the following error: "022 - Begin not possible due to limit switch" error.

The operands, `_LFx` and `_LRx`, contain the state of the forward and reverse limit switches, respectively (x represents the axis, X, Y, Z, W etc.). The value of the operand is either a '0' or '1' corresponding to the logic state of the limit switch. Using a terminal program, the state of a limit switch can be printed to the screen with the command, `MG_LFx` or `MG_LRx`. This prints the value of the limit switch operands for the 'x' axis. The logic state of the limit switches can also be interrogated with the TS command. For more details on TS see the Command Reference.

Home Switch Input

Homing inputs are designed to provide mechanical reference points for a motion control application. A transition in the state of a Home input alerts the controller that a particular reference point has been reached by a moving part in the motion control system. A reference point can be a point in space or an encoder index pulse.

The Home input detects any transition in the state of the switch and toggles between logic states 0 and 1 at every transition. A transition in the logic state of the Home input will cause the controller to execute a homing routine specified by the user.

There are three homing routines supported by the DMC-40x0: Find Edge (FE), Find Index (FI), and Standard Home (HM).

The Find Edge routine is initiated by the command sequence: FEX <return>, BGX <return>. The Find Edge routine will cause the motor to accelerate, and then slew at constant speed until a transition is detected in the logic state of the Home input. The direction of the FE motion is dependent on the state of the home switch. High level causes forward motion. The motor will then decelerate to a stop. The acceleration rate, deceleration rate and slew speed are specified by the user, prior to the movement, using the commands AC, DC, and SP. *When using the FE command, it is recommended that a high deceleration value be used so the motor will decelerate rapidly after sensing the Home switch.*

The Find Index routine is initiated by the command sequence: FIX <return>, BGX <return>. Find Index will cause the motor to accelerate to the user-defined slew speed (SP) at a rate specified by the user with the AC command and slew until the controller senses a change in the index pulse signal from low to high. The motor then decelerates to a stop at the rate previously specified by the user with the DC command and then moves back to the index pulse and speed HV. Although Find Index is an option for homing, it is not dependent upon a transition in the logic state of the Home input, but instead is dependent upon a transition in the level of the index pulse signal.

The Standard Homing routine is initiated by the sequence of commands HMX <return>, BGX <return>. Standard Homing is a combination of Find Edge and Find Index homing. Initiating the standard homing routine will cause the motor to slew until a transition is detected in the logic state of the Home input. The motor will accelerate at the rate specified by the command, AC, up to the slew speed. After detecting the transition in the logic state on the Home Input, the motor will decelerate to a stop at the rate specified by the command, DC. After the motor has decelerated to a stop, it switches direction and approaches the transition point at the speed of HV counts/sec. When the logic state changes again, the motor moves forward (in the direction of increasing encoder count) at the same speed, until the controller senses the index pulse. After detection, it decelerates to a stop, moves back to the index, and defines this position as 0. The logic state of the Home input can be interrogated with the command MG_HMX. This command returns a 0 or 1 if the logic state is low or high, respectively. The state of the Home input can also be interrogated indirectly with the TS command.

For examples and further information about Homing, see command HM, FI, FE of the Command Reference and the section entitled Homing in the Programming Motion Section of this manual.

Abort Input

The function of the Abort input is to immediately stop the controller upon transition of the logic state.

NOTE: The response of the abort input is significantly different from the response of an activated limit switch. When the abort input is activated, the controller stops generating motion commands immediately, whereas the limit switch response causes the controller to make a decelerated stop.

NOTE: The effect of an Abort input is dependent on the state of the off-on-error function for each axis. If the Off-On-Error function is enabled for any given axis, the motor for that axis will be turned off when the abort signal is generated. This could cause the motor to 'coast' to a stop since it is no longer under servo control. If the Off-On-Error function is disabled, the motor will decelerate to a stop as fast as mechanically possible and the motor will remain in a servo state.

All motion programs that are currently running are terminated when a transition in the Abort input is detected. This can be configured with the CN command. For information see the Command Reference, OE and CN.

ELO (Electronic Lock-Out) Input

Used in conjunction with Galil amplifiers, this input allows the user the shutdown the amplifier at a hardware level. For more detailed information on how specific Galil amplifiers behave when the ELO is triggered, see Integrated in the Appendices.

Reset Input

When this input is driven low, the controller will reset. This is the same as pressing the “RESET” button on the controller.

Uncommitted Digital Inputs

The DMC-40x0 has 8 opto-isolated inputs. These inputs can be read individually using the function @ IN[x] where x specifies the input number (1 thru 8). These inputs are uncommitted and can allow the user to create conditional statements related to events external to the controller. For example, the user may wish to have the x-axis motor move 1000 counts in the positive direction when the logic state of DI1 goes high.

This can be accomplished by connecting a voltage in the range of +5V to +28V into INCOM of the input circuitry from a separate power supply.

4080

Controllers with more than 4 axes have an additional 8 general opto-isolated inputs (inputs 9-16). The INCOM for these inputs is found on the I/O (E-H) D-Sub connector.

An additional 32 I/O are provided at 3.3V (5V option) through the extended I/O. These are not opto-isolated.

NOTE: INCOM and LSCOM for Inputs 9-16 and Limit and Home Switches for axes 5-8 are found on the connectors for the E-H axes. **These are NOT the same INCOM and LSCOM for axes 1-4.**

DI9-DI16	INCOM (I/O (E-H) D-Sub connectors)
FLSE,RLSE,HOME	LSCOM (I/O (E-H) D-Sub connector)
FLSF,RLSF,HOMF	
FLSG,RLSG,HOMG	
FLSH,RLSH,HOMH	

Wiring the Optoisolated Inputs

Electrical Specifications

Input Common (INCOM) Max Voltage	28 VDC
Limit Common (LSCOM) Max Voltage	28 VDC
Minimum Current to turn on Inputs	1 mA

Bi-Directional Capability

All inputs can be used as active high or low - If you are using an isolated power supply you can connect the positive voltage of the supply (+Vs) to INCOM or supply the isolated ground to INCOM. Connecting +Vs to INCOM will configure the inputs for active low. Connecting the isolated ground to INCOM will configure the inputs for active high. If there is not an isolated available, the Galil 5V or 12V and GND may be used. It is recommended to use an isolated supply for the optoisolated inputs.

The optoisolated inputs are configured into groups. For example, the general inputs, DI1-DI8 (inputs 1-8), the ABRT (abort) input and RST (reset) and ELO (electronic lock-out) inputs are one group. Figure 3.1 illustrates the internal circuitry. The INCOM signal is a common connection for all of the inputs in each group.

4080

The ELO, ABRT and RST pins are found on the I/O (A-D) D-Sub and are duplicated on the I/O (E-H) D-Sub. I.e. There is only one ELO, ABRT and RST input for an 8 axis controller. The common is the INCOM found on the I/O (A-D) D-Sub connector.

The optoisolated inputs are connected in the following groups:

Group (Controllers with 1- 4 Axes)	Common Signal
DI1-DI8, ABRT, RST, ELO	INCOM (I/O (A-D) D-Sub Connectors)
FLSA,RLSA,HOMA FLSB,RLSB,HOMB FLSC,RLSC,HOMC FLSD,RLSD,HOMD	LSCOM (I/O (A-D) D-Sub Connectors)
Group (Controllers with 5-8 Axes)	
DI1-DI8, ABRT, RST, ELO	INCOM (I/O (A-D) D-Sub Connectors)
FLSA,RLSA,HOMA FLSB,RLSB,HOMB FLSC,RLSC,HOMC FLSD,RLSD,HOMD	LSCOM (I/O (A-D) D-Sub Connectors)
DI9-DI16	INCOM (I/O (E-H) D-Sub Connectors)
FLSE,RLSE,HOME FLSF,RLSF,HOMF FLSG,RLSG,HOMG FLSH,RLSH,HOMH	LSCOM (I/O (E-H) D-Sub Connectors)

Table 3-1: INCOM and LSCOM information

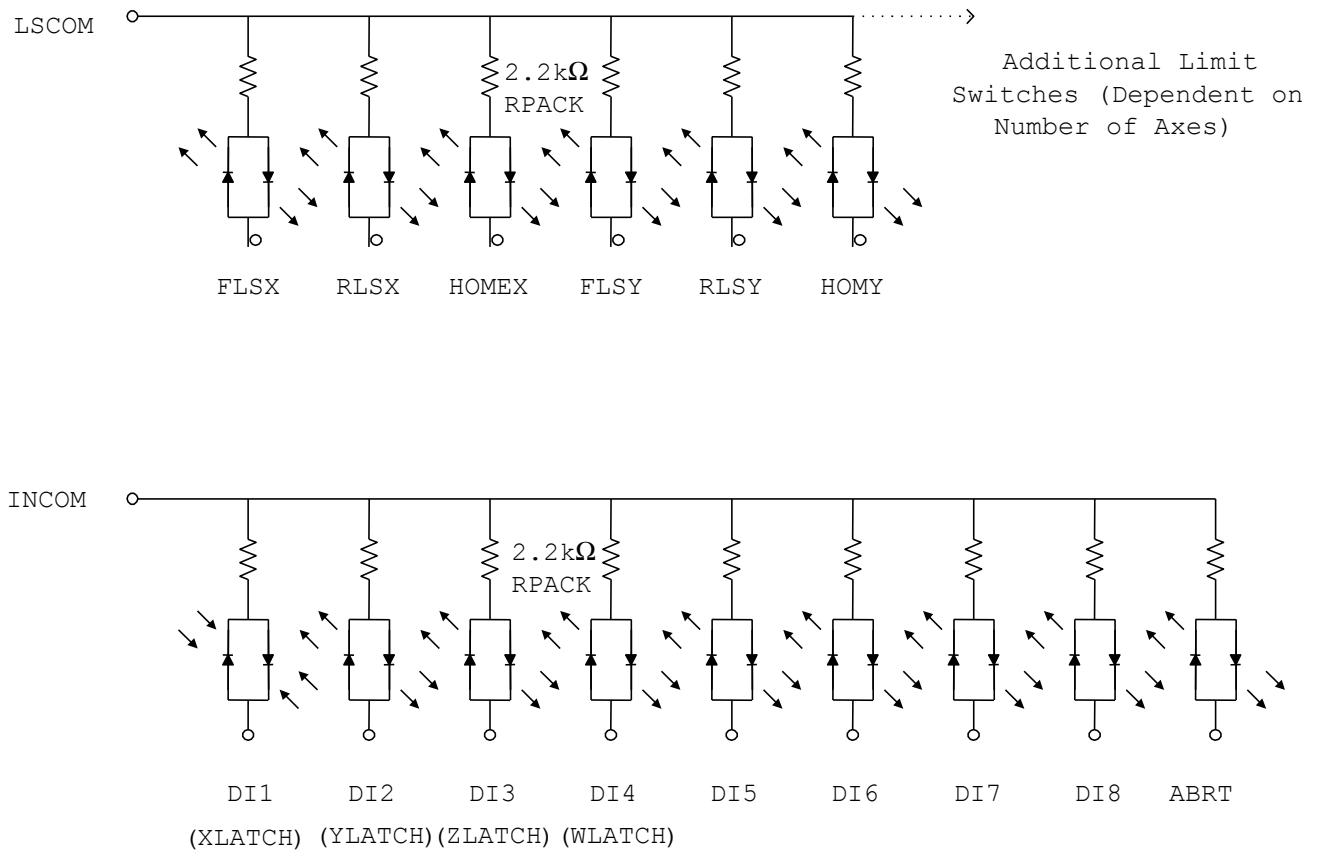

Figure 3-1: The Optoisolated Inputs.

Using an Isolated Power Supply

To take full advantage of opto-isolation, an isolated power supply should be used to provide the voltage at the input common connection. When using an isolated power supply, do not connect the ground of the isolated power to the ground of the controller. A power supply in the voltage range between 5 to 28 Volts may be applied directly (see Figure 3-2). For voltages greater than 28 Volts, a resistor, R, is needed in series with the input such that:

$$1 \text{ mA} < V_{\text{supply}} / (R + 2.2\text{K}\Omega) < 11 \text{ mA}$$

External Resistor Needed for Voltages > 28V

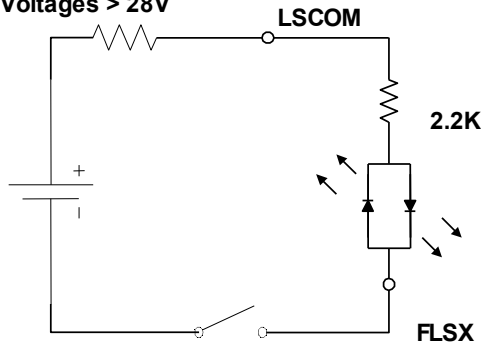

Configuration to source current at the LSCOM terminal and sink current at switch inputs

External Resistor Needed for Voltages > 28V

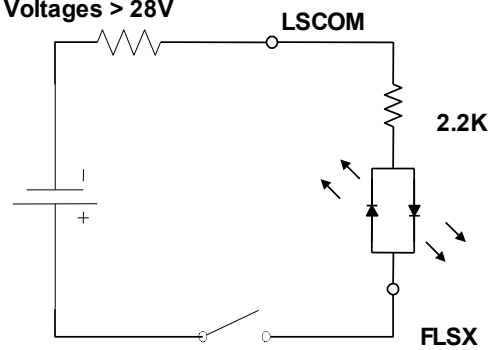

Configuration to sink current at the LSCOM terminal and source current at switch inputs

Figure 3-2. Connecting a single Limit or Home Switch to an Isolated Supply. This diagram only shows the connection for the forward limit switch of the X axis.

Bypassing the Opto-Isolation:

If no isolation is needed, the internal 5 Volt supply may be used to power the switches. This can be done by connecting LSCOM or INCOM to 5V.

To close the circuit, wire the desired input to any ground (GND) pin on the controller.

TTL Inputs

The Auxiliary Encoder Inputs

The auxiliary encoder inputs can be used for general use. For each axis, the controller has one auxiliary encoder and each auxiliary encoder consists of two inputs, channel A and channel B. The auxiliary encoder inputs are mapped to the inputs 81-96.

Each input from the auxiliary encoder is a differential line receiver and can accept voltage levels between +/- 12 volts. The inputs have been configured to accept TTL level signals. To connect TTL signals, simply connect the signal to the + input and leave the - input disconnected. For other signal levels, the - input should be connected to a voltage that is 1/2 of the full voltage range (for example, connect the - input to 6 volts if the signal is a 0 - 12 volt logic).

Example:

A DMC-4010 has one auxiliary encoder. This encoder has two inputs (channel A and channel B). Channel A input is mapped to input 81 and Channel B input is mapped to input 82. To use this input for 2 TTL signals, the first signal will be connected to AA+ and the second to AB+. AA- and AB- will be left unconnected. To access this input, use the function @IN[81] and @IN[82].

NOTE: The auxiliary encoder inputs are not available for any axis that is configured for stepper motor.

High Power Opto-Isolated Outputs

The DMC-40x0 has different interconnect module options, this section will describe the 500mA optically isolated outputs that are used on the ICM-42x00.

Electrical Specifications

Output Common Max Voltage	30 VDC
Output Common Min Voltage	12 VDC
Max Drive Current per Output	0.5 A (not to exceed 3A for all 8 outputs)

Wiring the Opto-Isolated Outputs

The ICM-42x00 module allows for opto-isolation on all of the digital inputs and outputs. The digital outputs are optically isolated and are capable of sourcing up to 0.5 A per pin with a 3 A limit for the group of 8 outputs. The outputs are configured for hi-side drive only. The supply voltage must be connected to *output supply voltage* (OPWR), and the supply return must be connected to *output return* (ORET).

Figure 3-3 shows the manner in which the load should be connected. The output will be at the voltage that is supplied to the OPWR pin. Up to 30 VDC may be supplied to OPWR.

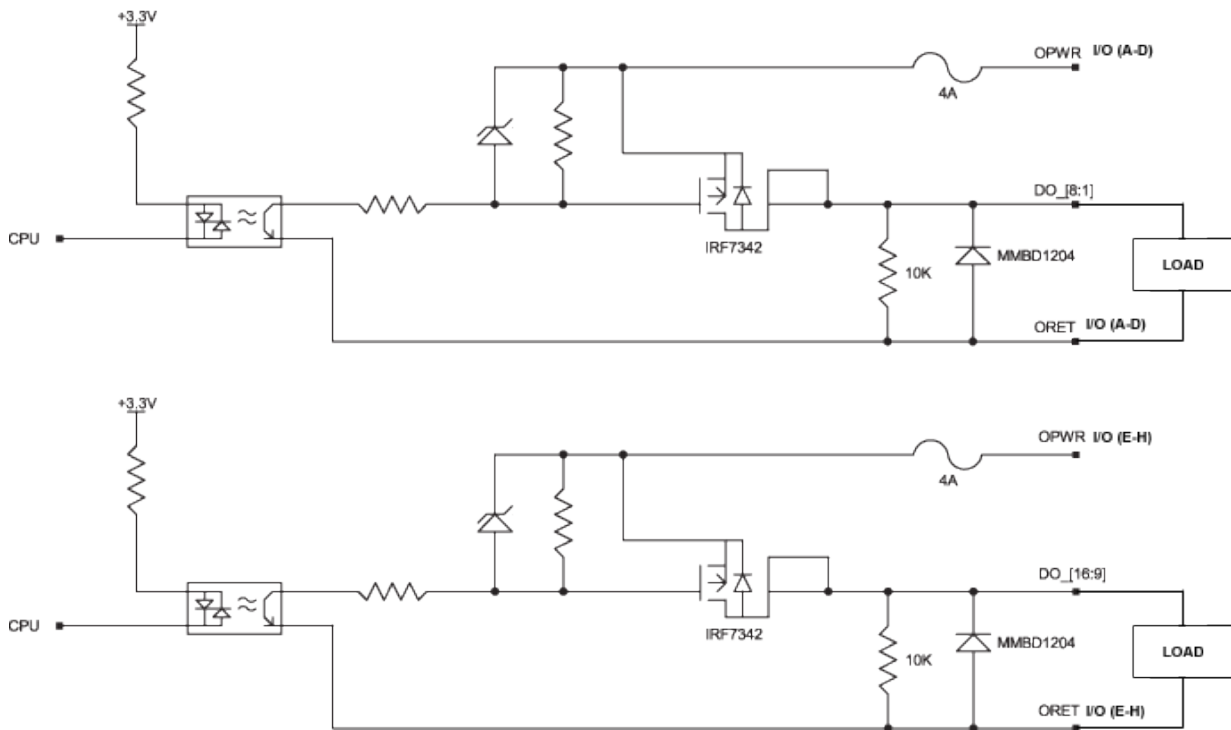

Figure 3-3 ICM-42x00 General-Purpose Digital Output Opto-Isolation

4080

For controllers with 5-8 axes, outputs 9-16 are located on the I/O (E-H) D-Sub connector. The OPWR and ORET for these outputs are also found on the I/O (E-H) D-Sub connector. Connections to the OPWR and ORET on the I/O (E-H) as described above are required for operation of outputs 9-16.

Analog Inputs

The DMC-40x0 has eight analog inputs configured for the range between -10V and 10V. The inputs are decoded by a 12-bit A/D decoder giving a voltage resolution of approximately .005V. A 16-bit ADC is available as an option (Ex. *DMC-4020(-16bit)-C012-I000*). The analog inputs are specified as AN[x] where x is a number 1 thru 8.

AQ settings

The analog inputs can be set to a range of +/-10V, +/-5V, 0-5V or 0-10V. The inputs can also be set into a differential mode where analog inputs 2,4,6 and 8 can be set to the negative differential inputs for analog inputs 1,3,5 and 7 respectively. See the AQ command in the command reference for more information.

Electrical Specifications

Input Impedance (12 and 16 bit) –

Single Ended (Unipolar) 42k Ω

Differential (Bipolar) 31k Ω

TTL Outputs

Output Compare

The output compare signal is TTL and is available on the I/O (A-D) D-Sub connector as CMP. Output compare is controlled by the position of any of the main encoders on the controller. The output can be programmed to produce an active low pulse (250 nsec) based on an incremental encoder value or to activate once when an axis position has been passed. When setup for a one shot, the output will stay low until the OC command is called again. For further information, see the command OC in the Command Reference.

4080

For controllers with 5-8 axes, a second output compare signal is available on the I/O (E-H) D-Sub connector.

Error Output

The controller provides a TTL signal, ERR, to indicate a controller error condition. When an error condition occurs, the ERR signal will go low and the controller LED will go on. An error occurs because of one of the following conditions:

1. At least one axis has a position error greater than the error limit. The error limit is set by using the command ER.
2. The reset line on the controller is held low or is being affected by noise.
3. There is a failure on the controller and the processor is resetting itself.
4. There is a failure with the output IC which drives the error signal.

The ERR signal is found on the I/O (A-D) D-Sub connector.

4080

For controllers with 5-8 axes, the ERR signal is duplicated on the I/O (E-H) D-Sub connector.

Extended I/O of the DMC-40x0 Controller

The DMC-40x0 controller offers 32 extended TTL I/O points which can be configured as inputs or outputs in 8 bit increments. Configuration is accomplished with command CO – see Extended I/O of the DMC-40x0 Controller. The I/O points are accessed through the 44 pin D-Sub connector labeled EXTENDED I/O. See the A5 – CMB-41012 (-C012) section in the Appendix for a complete pin out of the Extended I/O.

Electrical Specifications (3.3V – Standard)

Inputs

Max Input Voltage	3.4 VDC
Guarantee High Voltage	2.0 VDC
Guarantee Low Voltage	0.8 VDC

Inputs are internally pulled up to 3.3V through a 4.7k Ω resistor

Outputs

Sink/Source	4mA per output
-------------	----------------

Electrical Specifications (5V – Option)

Inputs

Max Input Voltage	5.25 VDC
Guarantee High Voltage	2.0 VDC
Guarantee Low Voltage	0.8 VDC

Inputs are internally pulled up to 5V through a 4.7k Ω resistor

Outputs

Sink/Source	20mA
-------------	------

Amplifier Interface

Electrical Specifications

Max Amplifier Enable Voltage	24V	
Max Amplifier Enable Current @24V	sink/source	25 mA
Motor Command Output Impedance	500 Ω	

Overview

The DMC-40x0 command voltage ranges between +/-10V and is output on the motor command line - MCMn (where n is A-H). This signal, along with GND, provides the input to the motor amplifiers. The amplifiers must be sized to drive the motors and load. For best performance, the amplifiers should be configured for a torque (current) mode of operation with no additional compensation. The gain should be set such that a 10 volt input results in the maximum required current.

Note: The DMC-40x0 controller has an option for differential motor command outputs. For more information contact Galil.

The DMC-40x0 also provides an amplifier enable signal - AENn (where n is A-H). This signal changes under the following conditions: the motor-off command, MO, is given, the watchdog timer activates, or the OE command (Enable Off-On-Error) is set and the position error exceeds the error limit or a limit switch is reached (see OE command in the Command Reference for more information).

For all versions of the ICM-42x00, the standard configuration of the amplifier enable signal is 5V active high amp enable (HAEN) sinking. In other words, the AEN signal will be high when the controller expects the amplifier to be enabled. The polarity and the amplitude can be changed by configuring the Amplifier Enable Circuit on the ICM-42x00.

If your amplifier requires a different configuration than the default 5V HAEN sinking it is highly recommended that the DMC-40x0 is ordered with the desired configuration. See the DMC-40x0 ordering information in the catalog (<http://www.galilmc.com/catalog/cat40x0.pdf>) or contact Galil for more information on ordering different configurations.

Note1: Many amplifiers designate the enable input as 'inhibit'.

ICM-42000 and ICM-42100 Amplifier Enable Circuit

This section describes how to configure the ICM-42000 and ICM-42100 for different Amplifier Enable configurations. It is advised that the user order the DMC-40x0 with the proper Amplifier enable configuration.

The ICM-42000 and ICM-42100 gives the user a broad range of options with regards to the voltage levels present on the enable signal. The user can choose between High-Amp-Enable (HAEN), Low-Amp-Enable (LAEN), 5V logic, 12V logic, external voltage supplies up to 24V, sinking, or sourcing. Tables 3-2 and 3-3 found below illustrate the settings for jumpers, resistor packs, and the socketed optocoupler IC. Refer to Figures 3-4 and 3-5 for precise physical locations of all components. Note that the resistor pack located at RP2 may be reversed to change the active state of the amplifier enable output. However, the polarity of RP6 must not be changed; a different resistor value may be needed to limit the current to 6 mA. The default value for RP6 is 820 ohms, which works at 5V. When using 24 V, RP6 should be replaced with a 4.7 k Ω resistor pack.

NOTE: For detailed step-by-step instructions on changing the Amplifier Enable configuration on the ICM-42000 or ICM-42100 see the Configuring the Amplifier Enable Circuit section in the Appendices.

**Amplifier Enable Circuit
Sinking Output Configuration
(Pin 1 of LTV8441 in Pin 2 of Socket U4)**

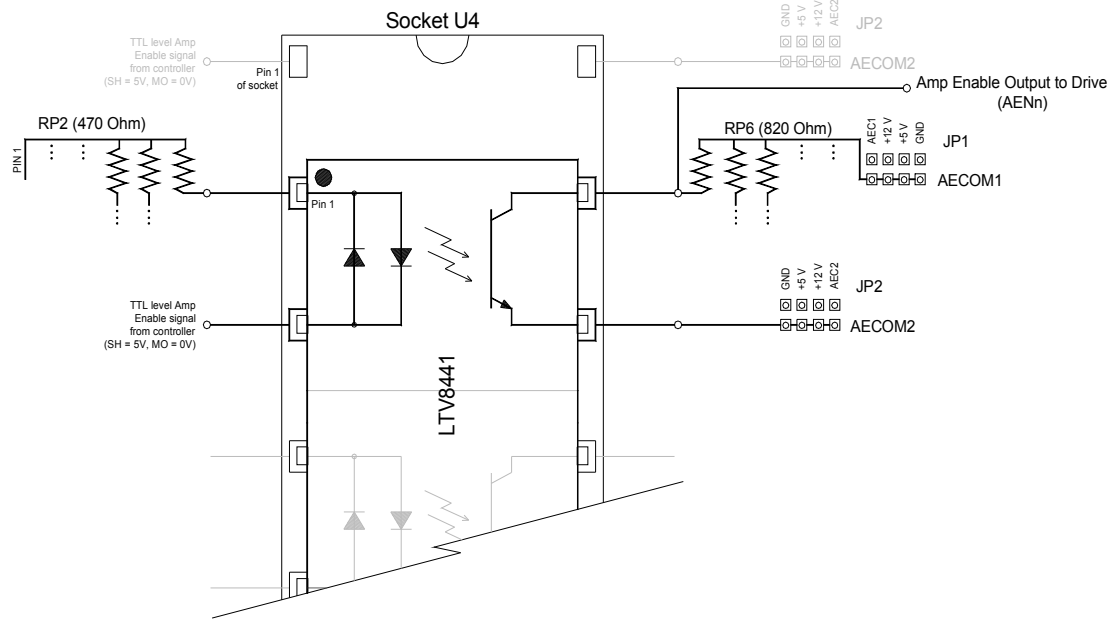

Figure 3-4: Amplifier Enable Circuit Sinking Output Configuration

Sinking Configuration (pin1 of LTV8441 chip in pin2 of socket U4)			
Logic State	JP1	JP2	RP2 (square pin next to RP2 label is 5V)
5V, HAEN (Default Configuration)	5V - AECOM1	GND - AECOM2	Dot on R-pack next to RP2 label
5V, LAEN	5V - AECOM1	GND - AECOM2	Dot on R-pack opposite RP2 label
12V, HAEN	+12V - AECOM1	GND - AECOM2	Dot on R-pack next to RP2 label
12V, LAEN	+12V - AECOM1	GND - AECOM2	Dot on R-pack opposite RP2 label
Isolated 24V, HAEN	AEC1 - AECOM1	AEC2 - AECOM2	Dot on R-pack next to RP2 label
Isolated 24V, LAEN	AEC1 - AECOM1	AEC2 - AECOM2	Dot on R-pack opposite RP2 label

For 24V isolated enable, tie +24V of external power supply to AEC1 at the D-sub, tie common return to AEC2. Replace RP6 with a 4.7 kΩ resistor pack. For Axes A-D, AEC1 and AEC2 are located on the EXTERNAL DRIVER (A-D) D-Sub connector. For Axes E-H, AEC1 and AEC2 are located on the EXTERNAL DRIVER (E-H) D-Sub connector.
Note: AEC1 and AEC2 for axes A-D are NOT connected to AEC1 and AEC2 for axes E-H.

Table 3-2: Sinking Configuration

Amplifier Enable Circuit
Sourcing Output Configuration
(Pin 1 of LTV8441 in Pin 1 of Socket U4)

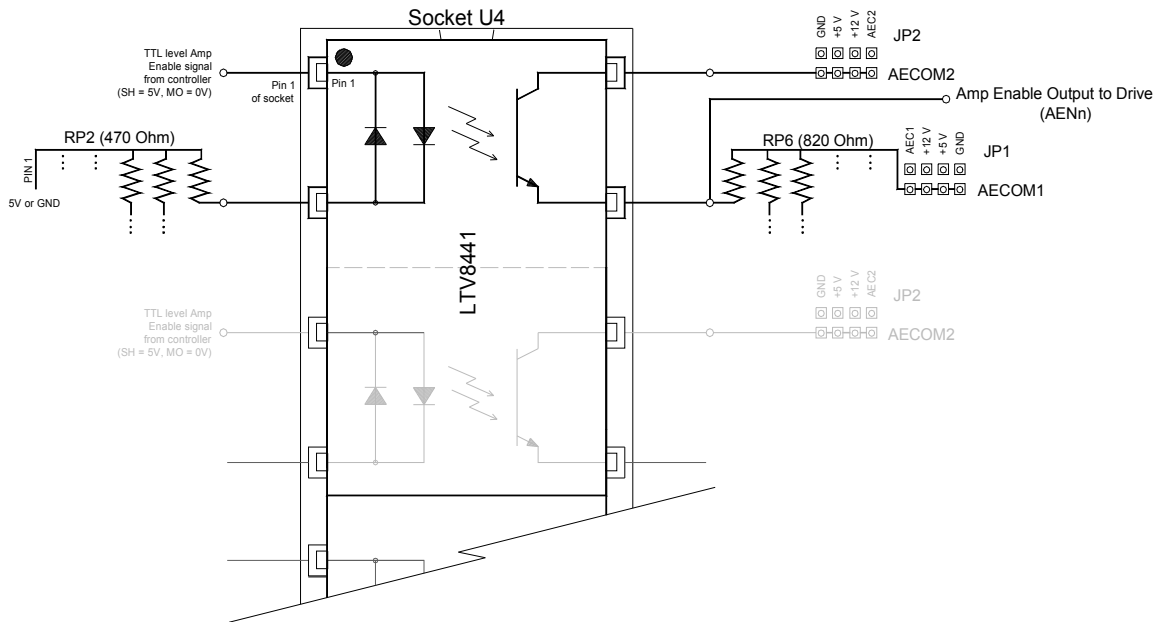

Figure 3-5: Amplifier Enable Circuit Sourcing Output Configuration

Sourcing Configuration (pin1 of LTV8441 chip in pin1 of socket U4)			
Logic State	JP1	JP2	RP2 (square pin next to RP2 label is 5V)
5V, HAEN	GND – AECOM1	5V – AECOM2	Dot on R-pack opposite RP2 label
5V, LAEN	GND – AECOM1	5V – AECOM2	Dot on R-pack next to RP2 label
12V, HAEN	GND – AECOM1	+12V – AECOM2	Dot on R-pack opposite RP2 label
12V, LAEN	GND – AECOM1	+12V – AECOM2	Dot on R-pack next to RP2 label
Isolated 24V, HAEN	AEC1 – AECOM1	AEC2 - AECOM2	Dot on R-pack opposite RP2 label
Isolated 24V, LAEN	AEC1 - AECOM1	AEC2 – AECOM2	Dot on R-pack next to RP2 label

For 24V isolated enable, tie +24V of external power supply to AEC2 at the D-sub, tie common return to AEC1. Replace RP6 with a 4.7 kΩ resistor pack. For Axes A-D, AEC1 and AEC2 are located on the EXTERNAL DRIVER (A-D) D-Sub connector. For Axes E-H, AEC1 and AEC2 are located on the EXTERNAL DRIVER (E-H) D-Sub connector. **Note:** AEC1 and AEC2 for axes A-D are NOT connected to AEC1 and AEC2 for axes E-H.

Table3-3: Sourcing Configuration

ICM-42200 Amplifier Enable Circuit

This section describes how to configure the ICM-42200 for different Amplifier Enable outputs. The ICM-42200 is designed to be used with external amplifiers. As a result, the amplifier enable circuit for each axis is individually configurable through jumper settings. The user can choose between High-Amp-Enable (HAEN), Low-Amp-Enable (LAEN), 5V logic, 12V logic, external voltage supplies up to 24V, sinking, or sourcing. Every different configuration is described below with jumper settings and a schematic of the circuit.

**+5V
HIGH AMP ENABLE
SINKING**

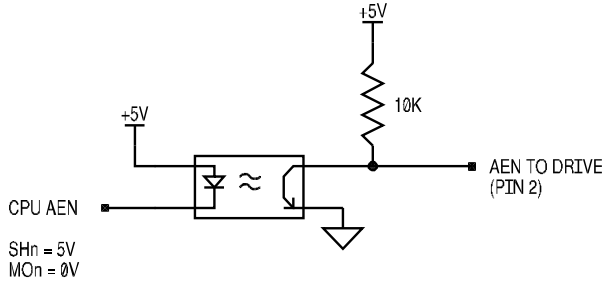
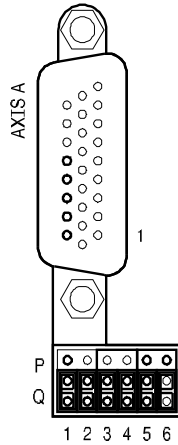

**+12V
HIGH AMP ENABLE
SINKING**

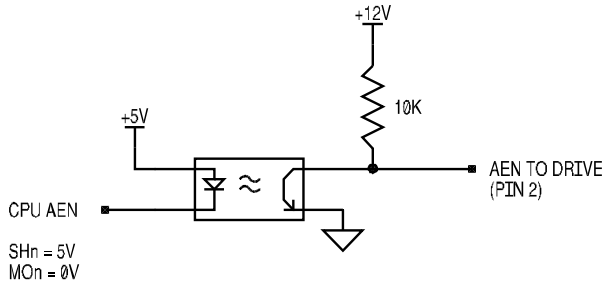
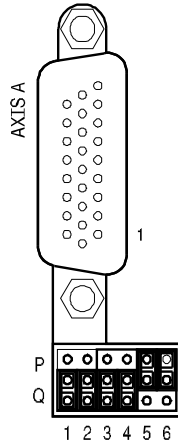

**ISOLATED SUPPLY
HIGH AMP ENABLE
SINKING**

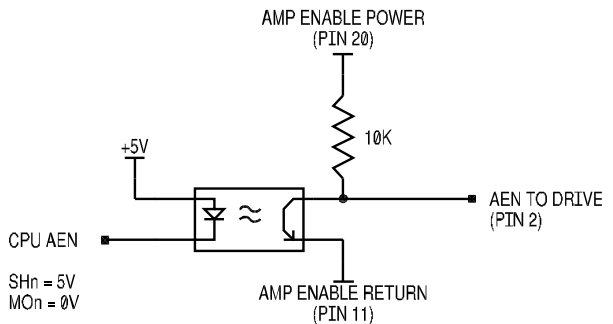
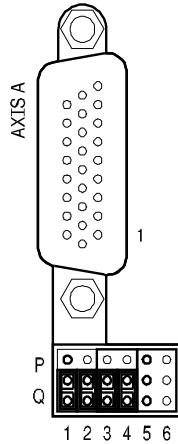

**+5V
LOW AMP ENABLE
SINKING**

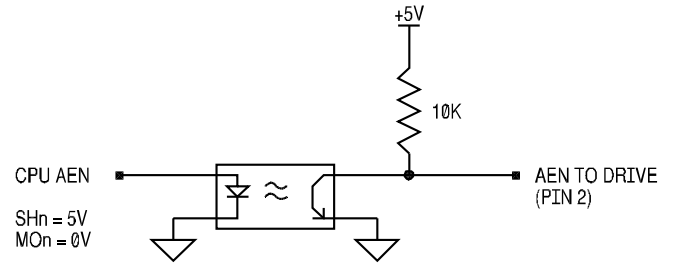
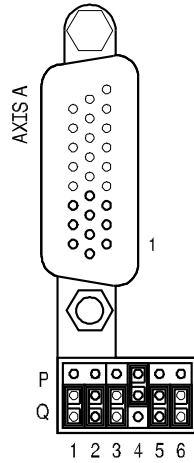

**+12V
LOW AMP ENABLE
SINKING**

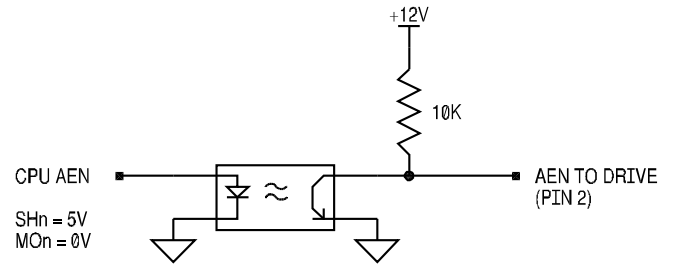
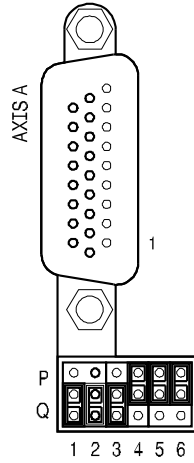

**ISOLATED SUPPLY
LOW AMP ENABLE
SINKING**

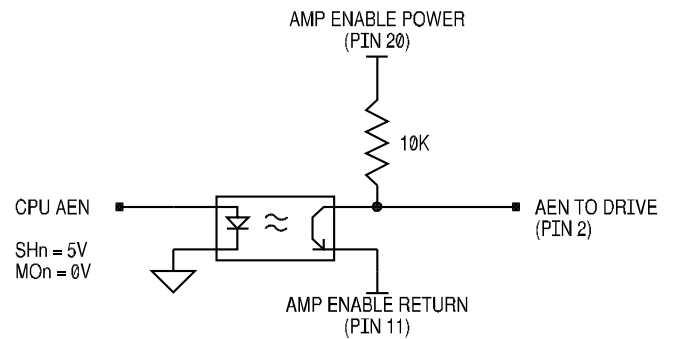
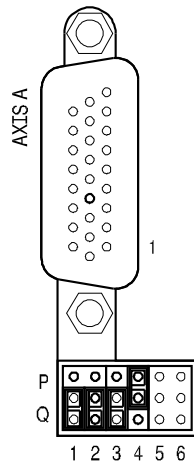

**+5V
HIGH AMP ENABLE
SOURCING**

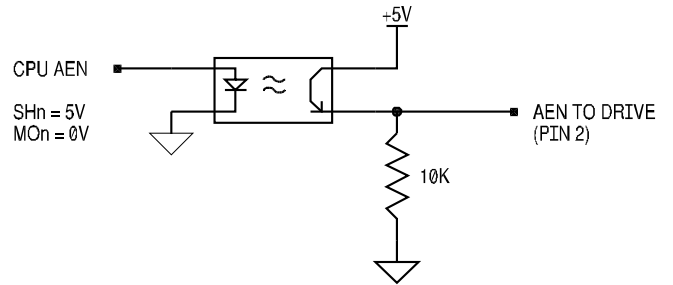
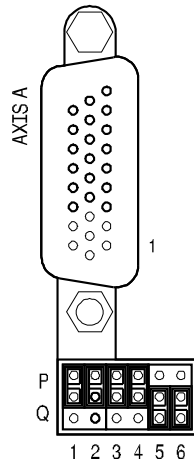

**+12V
HIGH AMP ENABLE
SOURCING**

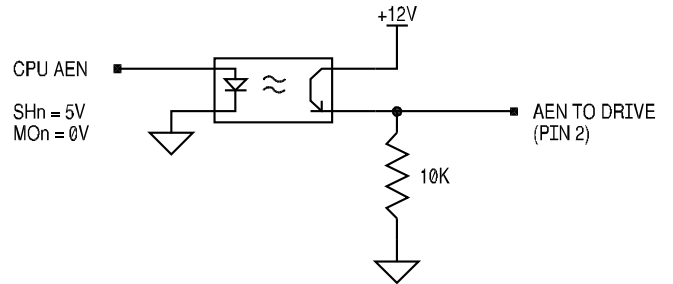
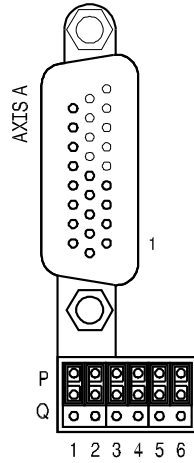

**ISOLATED SUPPLY
HIGH AMP ENABLE
SOURCING**

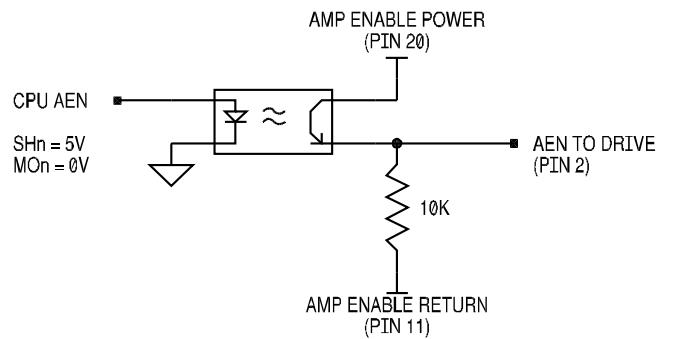
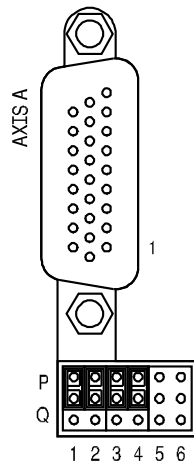

**+5V
LOW AMP ENABLE
SOURCING**

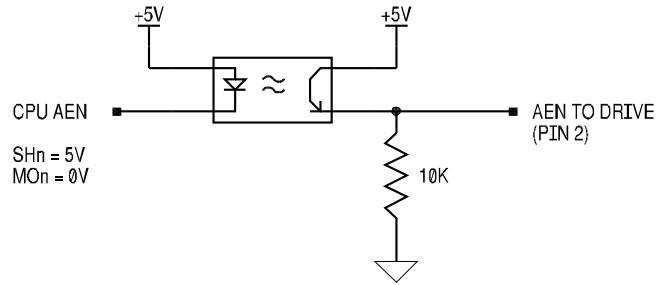
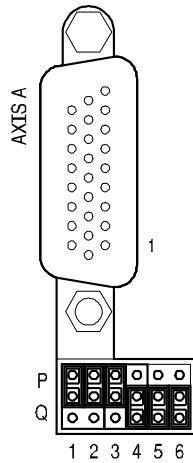

**+12V
LOW AMP ENABLE
SOURCING**

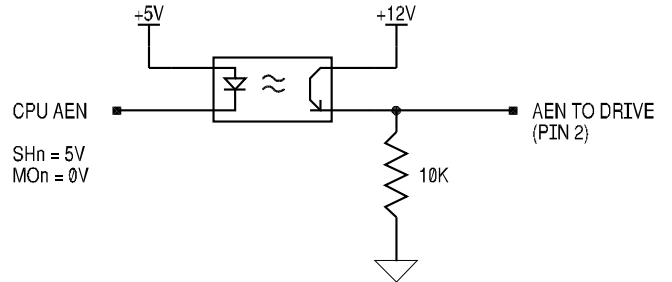
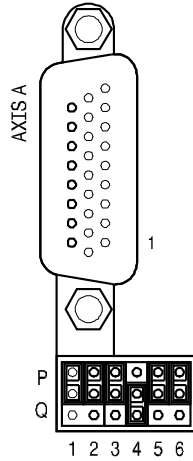

**ISOLATED SUPPLY
LOW AMP ENABLE
SOURCING**

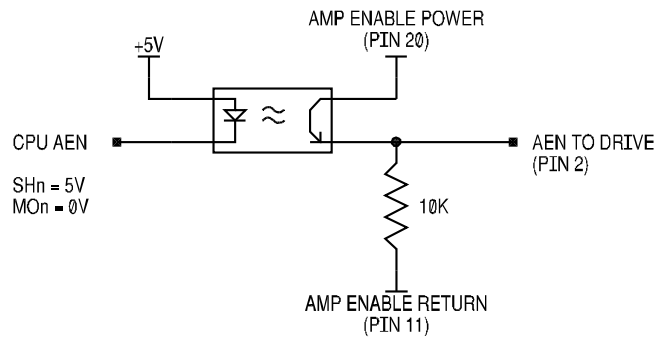
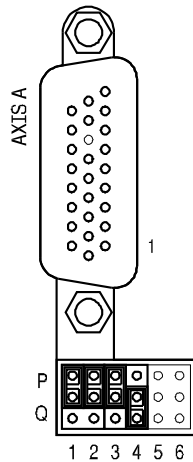

Chapter 4 Software Tools and Communication

Introduction

The default configuration DMC-40x0 has two RS232 ports and 1 Ethernet port. The main RS-232 port is the data set and can be configured through the jumpers on the top of the controller. The auxiliary RS-232 port is the data term and can be configured with the software command CC. The auxiliary RS-232 port can be configured either for daisy chain operation or as a general port. This configuration can be saved using the Burn (BN) instruction. The RS232 ports also have a clock synchronizing line that allows synchronization of motion on more than one controller.

Galil software is available for PC computers running Microsoft Windows® to communicate with the DMC-40x0 controller. Standard Galil communications software utilities are available for Windows operating systems, which includes **GalilTools**. This software package has been developed to operate under Windows and Linux, and include all the necessary drivers to communicate to the controller. In addition, GalilTools includes a software development communication library which allows users to create their own application interfaces using programming environments such as C, C++, Visual Basic, and LabVIEW.

The following sections in this chapter are a description of the communications protocol, and a brief introduction to the software tools and communication techniques used by Galil. At the application level, GalilTools is the basic programs that the majority of users will need to communicate with the controller, to perform basic setup, and to develop application code (.DMC programs) that is downloaded to the controller. At the Galil API level, the GalilTools Communication Library is available for users, who wish to develop their own custom application programs to communicate to the controller. Custom application programs can utilize API function calls directly to our DLL's. At the driver level, we provide fundamental hardware interface information for users who desire to create their own drivers.

RS232 and RS422 Ports

The RS232 pin-out description for the main and auxiliary port is given below. Note that the auxiliary port is essentially the same as the main port except inputs and outputs are reversed. The DMC-40x0 may also be configured by the factory for RS422. These pin-outs are also listed below.

RS-232 Configuration

NOTE: If you are connecting the RS232 auxiliary port to a terminal or any device which is a DATASET, it is necessary to use a connector adapter, which changes a dataset to a dataterm. This cable is also known as a 'null' modem cable.

RS232 - Main Port {P1} DATATERM

- | | |
|--------------------------|----------------------------|
| 1 No Connect | 6 No Connect |
| 2 Transmit Data - output | 7 Clear To Send - input |
| 3 Receive Data - input | 8 Request To Send - output |
| 4 No Connect | 9 No connect |
| 5 Ground | |

RS232 - Auxiliary Port {P2} DATASET

- | | |
|--------------------------|--|
| 1 No Connect | 6 No Connect |
| 2 Receive Data - input | 7 Request To Send - output |
| 3 Transmit Data - output | 8 Clear To Send - input |
| 4 No Connect | 9 No Connect (Can be connected to 5V with APWR jumper) |
| 5 Ground | |

Configuration

Configure your PC for 8-bit data, one start-bit, one stop-bit, full duplex and no parity. The baud rate for the RS232 communication can be selected by setting the proper switch configuration on the front panel according to the table below.

Baud Rate Selection

SWITCH SETTINGS		
19.2	38.4	BAUD RATE
ON	ON	9600
ON	OFF	19200
OFF	ON	38400
OFF	OFF	115200

Handshaking

The RS232 main port is set for hardware handshaking. Hardware Handshaking uses the RTS and CTS lines. The CTS line will go high whenever the DMC-40x0 is not ready to receive additional characters. The RTS line will inhibit the DMC-40x0 from sending additional characters. Note, the RTS line goes high for inhibit.

The auxiliary port of the DMC-40x0 can be configured either as a general port or for the daisy-chain. When configured as a general port, the port can be commanded to send ASCII messages to another DMC-40x0 controller or to a display terminal or panel.

CC Command: (Configure Communication) at port 2. The command is in the format of (See CC in the Command Reference for more information):

CC m,n,r,p

where 'm' sets the baud rate, 'n' sets for either handshake or non-handshake mode, 'r' sets for general port or the auxiliary port, and 'p' turns echo on or off.

m - Baud Rate - 9600,19200,38400,115200

n - Handshake - 0=No; 1=Yes

r - Mode - 0=Disabled; 1=enabled

p - Echo - 0=Off; 1=On; Valid only if r=0

NOTE: for the handshake of the auxiliary port, the roles for the RTS and CTS lines are reversed.

Example:

CC 19200,0,1,1 Configure auxiliary communication port for 19200 baud, no handshake, general port mode and echo turned on.

RS-422 Configuration

The DMC-40x0 can be ordered with the main and/or auxiliary port configured for RS-422 communication. RS-422 communication is a differentially driven serial communication protocol that should be used when long distance serial communication is required in an application.

RS-422-Main Port (Non-Standard Option)

Standard connector and cable when DMC-40x0 is ordered with RS-422 Option.

Pin	Signal
1	RTS-
2	TXD-
3	RXD-
4	CTS-
5	GND
6	RTS+
7	TXD+
8	RXD+
9	CTS+

RS-422-Auxiliary Port (Non-Standard Option)

Standard connector and cable when DMC-40x0 is ordered with RS-422 Option.

Pin	Signal
1	CTS-
2	RXD-
3	TXD-
4	RTS-
5	GND
6	CTS+
7	RXD+
8	TXD+
9	RTS+

Ethernet Configuration**Communication Protocols**

The Ethernet is a local area network through which information is transferred in units known as packets. Communication protocols are necessary to dictate how these packets are sent and received. The DMC-40x0 supports two industry standard protocols, TCP/IP and UDP/IP. The controller will automatically respond in the format in which it is contacted.

TCP/IP is a "connection" protocol. The master must be connected to the slave in order to begin communicating. Each packet sent is acknowledged when received. If no acknowledgement is received, the information is assumed lost and is resent.

Unlike TCP/IP, UDP/IP does not require a "connection". This protocol is similar to communicating via RS232. If information is lost, the controller does not return a colon or question mark. Because the protocol does not provide for lost information, the sender must re-send the packet.

Although UDP/IP is more efficient and simple, Galil recommends using the TCP/IP protocol. TCP/IP insures that if a packet is lost or destroyed while in transit, it will be resent.

Ethernet communication transfers information in 'packets'. The packets must be limited to 512 data bytes (including UDP/TCP IP Header) or less. Larger packets could cause the controller to lose communication.

NOTE: In order not to lose information in transit, Galil recommends that the user wait for an acknowledgement of receipt of a packet before sending the next packet.

Addressing

There are three levels of addresses that define Ethernet devices. The first is the MAC or hardware address. This is a unique and permanent 6 byte number. No other device will have the same MAC address. The DMC-40x0 MAC address is set by the factory and the last two bytes of the address are the serial number of the board. To find the Ethernet MAC address for a DMC-40x0 unit, use the TH command. A sample is shown here with a unit that has a serial number of 3:

Sample MAC Ethernet Address: 00-50-4C-20-04-AF

The second level of addressing is the IP address. This is a 32-bit (or 4 byte) number that usually looks like this: 192.168.15.1. The IP address is constrained by each local network and must be assigned locally. Assigning an IP address to the DMC-40x0 controller can be done in a number of ways.

The first method for setting the IP address is using a DHCP server. The DH command controls whether the DMC-40x0 controller will get an IP address from the DHCP server. If the unit is set to DH1 (default) and there is a DHCP server on the network, the controller will be dynamically assigned an IP address from the server. Setting the board to DH0 will prevent the controller from being assigned an IP address from the server.

The second method to assign an IP address is to use the BOOT-P utility via the Ethernet connection. The BOOT-P functionality is only enabled when DH is set to 0. Either a BOOT-P server on the internal network or the Galil software may be used. When opening the Galil Software, it will respond with a list of all DMC-40x0's and other controllers on the network that do not currently have IP addresses. The user must select the board and the software will assign the specified IP address to it. This address will be burned into the controller (BN) internally to save the IP address to the non-volatile memory.

NOTE: if multiple boards are on the network – use the serial numbers to differentiate them.

CAUTION: Be sure that there is only one BOOT-P or DHCP server running. If your network has DHCP or BOOT-P running, it may automatically assign an IP address to the DMC-40x0 controller upon linking it to the network. In order to ensure that the IP address is correct, please contact your system administrator before connecting the I/O board to the Ethernet network.

The third method for setting an IP address is to send the IA command through the RS-232 port. (Note: The IA command is only valid if DH0 is set). The IP address may be entered as a 4 byte number delimited by commas (industry standard uses periods) or a signed 32 bit number (e.g. IA 124,51,29,31 or IA 2083724575). Type in BN to save the IP address to the DMC-40x0 non-volatile memory.

NOTE: Galil strongly recommends that the IP address selected is not one that can be accessed across the Gateway. The Gateway is an application that controls communication between an internal network and the outside world.

The third level of Ethernet addressing is the UDP or TCP port number. The Galil board does not require a specific port number. The port number is established by the client or master each time it connects to the DMC-40x0 board. Typical port numbers for applications are:

Port 23: Telnet

Port 502: Modbus

Communicating with Multiple Devices

The DMC-40x0 is capable of supporting multiple masters and slaves. The masters may be multiple PC's that send commands to the controller. The slaves are typically peripheral I/O devices that receive commands from the controller.

NOTE: The term "Master" is equivalent to the internet "client". The term "Slave" is equivalent to the internet "server".

An Ethernet handle is a communication resource within a device. The DMC-40x0 can have a maximum of 8 Ethernet handles open at any time. When using TCP/IP, each master or slave uses an individual Ethernet handle. In UDP/IP, one handle may be used for all the masters, but each slave uses one. (Pings and ARPs do not occupy handles.) If all 8 handles are in use and a 9th master tries to connect, it will be sent a "reset packet" that generates the appropriate error in its windows application.

NOTE: There are a number of ways to reset the controller. Hardware reset (push reset button or power down controller) and software resets (through Ethernet or RS232 by entering RS). The only reset that will not cause the controller to disconnect is a software reset via the Ethernet.

When the Galil controller acts as the master, the IH command is used to assign handles and connect to its slaves. The IP address may be entered as a 4 byte number separated with commas (industry standard uses periods) or as a signed 32 bit number. A port number may also be specified, but if it is not, it will default to 1000. The protocol (TCP/IP or UDP/IP) to use must also be designated at this time. Otherwise, the controller will not connect to the slave. (Ex. IHB=151,25,255,9<179>2 This will open handle #2 and connect to the IP address 151.25.255.9, port 179, using TCP/IP)

Which devices receive what information from the controller depends on a number of things. If a device queries the controller, it will receive the response unless it explicitly tells the controller to send it to another device. If the command that generates a response is part of a downloaded program, the response will route to whichever port is specified as the default (unless explicitly told to go to another port with the CF command). To designate a specific destination for the information, add {Eh} to the end of the command. (Ex. MG{EC}"Hello" will send the message "Hello" to handle #3. TP,,?{EF} will send the z axis position to handle #6.)

Multicasting

A multicast may only be used in UDP/IP and is similar to a broadcast (where everyone on the network gets the information) but specific to a group. In other words, all devices within a specified group will receive the information that is sent in a multicast. There can be many multicast groups on a network and are differentiated by their multicast IP address. To communicate with all the devices in a specific multicast group, the information can be sent to the multicast IP address rather than to each individual device IP address. All Galil controllers belong to a default multicast address of 239.255.19.56. The controller's multicast IP address can be changed by using the IA> u command.

Using Third Party Software

Galil supports DHCP, ARP, BOOT-P, and Ping which are utilities for establishing Ethernet connections. DHCP is a protocol used by networked devices (clients) to obtain the parameters necessary for operation in an Internet Protocol network. ARP is an application that determines the Ethernet (hardware) address of a device at a specific IP address. BOOT-P is an application that determines which devices on the network do not have an IP address and assigns the IP address you have chosen to it. Ping is used to check the communication between the device at a specific IP address and the host computer.

The DMC-40x0 can communicate with a host computer through any application that can send TCP/IP or UDP/IP packets. A good example of this is Telnet, a utility that comes with most Windows systems.

Modbus

An additional protocol layer is available for speaking to I/O devices. Modbus is an RS-485 protocol that packages information in binary packets that are sent as part of a TCP/IP packet. In this protocol, each slave has a 1 byte slave address. The DMC-40x0 can use a specific slave address or default to the handle number. The port number for Modbus is 502.

The Modbus protocol has a set of commands called function codes. The DMC-40x0 supports the 10 major function codes:

Function Code	Definition
01	Read Coil Status (Read Bits)
02	Read Input Status (Read Bits)
03	Read Holding Registers (Read Words)
04	Read Input Registers (Read Words)
05	Force Single Coil (Write One Bit)
06	Preset Single Register (Write One Word)
07	Read Exception Status (Read Error Code)
15	Force Multiple Coils (Write Multiple Bits)
16	Preset Multiple Registers (Write Words)
17	Report Slave ID

The DMC-40x0 provides three levels of Modbus communication. The first level allows the user to create a raw packet and receive raw data. It uses the MBh command with a function code of -1. The format of the command is

$$\text{MBh} = -1, \text{len}, \text{array}[] \quad \text{where} \quad \text{len} \text{ is the number of bytes}$$

$$\text{array}[] \text{ is the array with the data}$$

The second level incorporates the Modbus structure. This is necessary for sending configuration and special commands to an I/O device. The formats vary depending on the function code that is called. For more information refer to the Command Reference.

The third level of Modbus communication uses standard Galil commands. Once the slave has been configured, the commands that may be used are @IN[], @AN[], SB, CB, OB, and AO. For example, AO 2020,8.2 would tell I/O number 2020 to output 8.2 volts.

If a specific slave address is not necessary, the I/O number to be used can be calculated with the following:

$$\text{I/O Number} = (\text{HandleNum} * 1000) + ((\text{Module}-1) * 4) + (\text{BitNum}-1)$$

Where HandleNum is the handle number from 1 (A) to 6 (F). Module is the position of the module in the rack from 1 to 16. BitNum is the I/O point in the module from 1 to 4.

If an explicit slave address is to be used, the equation becomes:

$$\text{I/O Number} = (\text{SlaveAddress} * 10000) + (\text{HandleNum} * 1000) + ((\text{Module}-1) * 4) + (\text{Bitnum}-1)$$

Modbus Examples

Example #1

DMC-4040 connected as a Modbus master to a RIO-47120 via Modbus. The DMC-4040 will set or clear all 16 of the RIO's digital outputs

1. Begin by opening a connection to the RIO which in our example has IP address 192.168.1.120

```
IHB=192,168,1,120<502          (Issued to DMC-4040)
```

2. Dimension an array to store the commanded values. Set array element 0 equal to 170 and array element 1 equal to 85. (array element 1 configures digital outputs 15-8 and array element 0 configures digital outputs 7-0)

```
DM myarray[2]
myarray[0] = 170          (which is 10101010 in binary)
myarray[1] = 85          (which is 01010101 in binary)
```

3. a) Send the appropriate MB command. Use function code 15. Start at output 0 and set/clear all 16 outputs based on the data in myarray[]

```
MBB=,15,0,16,myarray[]
```

3. b) Set the outputs using the SB command.

```
SB2001;SB2003;SB2005;SB2007;SB2008;SB2010;SB2012;SB2014;
```

Results:

Both steps 3a and 3b will result in outputs being activated as below. The only difference being that step 3a will set and clear all 16 bits where as step 3b will only set the specified bits and will have no affect on the others.

Bit Number	Status
0	0
1	1
2	0
3	1
4	0
5	1
6	0
7	1

Bit Number	Status
8	1
9	0
10	1
11	0
12	1
13	0
14	1
15	0

Example #2

DMC-4040 connected as a Modbus master to a 3rd party PLC. The DMC-4040 will read the value of analog inputs 3 and 4 on the PLC located at addresses 40006 and 40008 respectively. The PLC stores values as 32-bit floating point numbers which is common.

1. Begin by opening a connection to the PLC which has an IP address of 192.168.1.10 in our example

```
IHB=192,168,1,10<502
```

2. Dimension an array to store the results

```
DM myanalog[4]
```

3. Send the appropriate MB command. Use function code 4 (as specified per the PLC). Start at address 40006. Retrieve 4 modbus registers (2 modbus registers per 1 analog input, as specified by the PLC)

```
MBB=,4,40006,4,myanalog[]
```

Results:

Array elements 0 and 1 will make up the 32 bit floating point value for analog input 3 on the PLC and array elements 2 and 3 will combine for the value of analog input 4.

```
myanalog[0]=16412=0x401C  
myanalog[1]=52429=0xCCCC  
myanalog[2]=49347=0xC0C3  
myanalog[3]=13107=0x3333
```

Analog input 3 = 0x401CCCCD = 2.45V

Analog input 4 = 0xC0C33333 = -6.1V

Example #3

DMC-4040 connected as a Modbus master to a hydraulic pump. The DMC-4040 will set the pump pressure by writing to an analog output on the pump located at Modbus address 30000 and consisting of 2 Modbus registers forming a 32 bit floating point value.

1. Begin by opening a connection to the pump which has an IP address of 192.168.1.100 in our example

```
IHB=192,168,1,100<502
```

2. Dimension and fill an array with values that will be written to the PLC

```
DM pump[2]  
pump[0]=16531=0x4093  
pump[1]=13107=0x3333
```

3. Send the appropriate MB command. Use function code 16. Start at address 30000 and write to 2 registers using the data in the array pump[]

```
MBB=,16,30000,2,pump[]
```

Results:

Analog output will be set to 0x40933333 which is 4.6V

To view an example procedure for communicating with an OPTO-22 rack, refer to Example- Communicating with OPTO-22 SNAP-B3000-ENET in the Appendices.

Data Record

The DMC-40x0 can provide a block of status information with the use of a single command, QR. This command, along with the QZ command can be very useful for accessing complete controller status. The QR command will return 4 bytes of header information and specific blocks of information as specified by the command arguments:

```
QR ABCDEFGHST
```

Each argument corresponds to a block of information according to the Data Record Map below. If no argument is given, the entire data record map will be returned. Note that the data record size will depend on the number of axes.

Note: UB = Unsigned Byte (1), UW = Unsigned Word (2), SW = Signed Word (2), SL = Signed Long Word (4), UL = Unsigned Long Word (4)

ADDR	TYPE	ITEM
00	UB	1 st Byte of Header
01	UB	2 nd Byte of Header
02	UB	3 rd Byte of Header
03	UB	4 th Byte of Header
04-05	UW	sample number
06	UB	general input block 0 (inputs 1-8)
07	UB	general input block 1 (inputs 9-16)
08	UB	general input block 2 (inputs 17-24)
09	UB	general input block 3 (inputs 25-32)
10	UB	general input block 4 (inputs 33-40)
11	UB	general input block 5 (inputs 41-48)
12	UB	general input block 6 (inputs 49-56)
13	UB	general input block 7 (inputs 57-64)
14	UB	general input block 8 (inputs 65-72)
15	UB	general input block 9 (inputs 73-80)
16	UB	general output block 0 (outputs 1-8)
17	UB	general output block 1 (outputs 9-16)
18	UB	general output block 2 (outputs 17-24)
19	UB	general output block 3 (outputs 25-32)
20	UB	general output block 4 (outputs 33-40)
21	UB	general output block 5 (outputs 41-48)
22	UB	general output block 6 (outputs 49-56)
23	UB	general output block 7 (outputs 57-64)
24	UB	general output block 8 (outputs 65-72)
25	UB	general output block 9 (outputs 73-80)
26-27	SW (new)	Reserved
28-29	SW (new)	Reserved
30-31	SW (new)	Reserved
32-33	SW (new)	Reserved
34-35	SW (new)	Reserved
36-37	SW (new)	Reserved
38-39	SW (new)	Reserved
40-41	SW (new)	Reserved
42	UB	Ethernet Handle A Status
43	UB	Ethernet Handle B Status
44	UB	Ethernet Handle C Status
45	UB	Ethernet Handle D Status
46	UB	Ethernet Handle E Status
47	UB	Ethernet Handle F Status
48	UB	Ethernet Handle G Status
49	UB	Ethernet Handle H Status

50	UB	error code
51	UB	thread status – see bit field map below
52-55	UL (new)	Amplifier Status
56-59	UL (new)	Segment Count for Contour Mode
60-61	UW (new)	Buffer space remaining – Contour Mode
62-63	UW	segment count of coordinated move for S plane
64-65	UW	coordinated move status for S plane – see bit field map below
66-69	SL	distance traveled in coordinated move for S plane
70-71	UW (new)	Buffer space remaining – S Plane
72-73	UW	segment count of coordinated move for T plane
74-75	UW	Coordinated move status for T plane – see bit field map below
76-79	SL	distance traveled in coordinated move for T plane
80-81	UW (new)	Buffer space remaining – T Plane
Axis information:		
82-83	UW	A axis status – see bit field map below
84	UB	A axis switches – see bit field map below
85	UB	A axis stop code
86-89	SL	A axis reference position
90-93	SL	A axis motor position
94-97	SL	A axis position error
98-101	SL	A axis auxiliary position
102-105	SL	A axis velocity
106-109	SL (new size)	A axis torque
110-111	SW or UW ¹	A axis analog input
112	UB(new)	A Hall Input Status
113	UB	Reserved
114-117	SL (new)	A User defined variable (ZA)
118-119	UW	B axis status – see bit field map below
120	UB	B axis switches – see bit field map below
121	UB	B axis stop code
122-125	SL	B axis reference position
126-129	SL	B axis motor position
130-133	SL	B axis position error
134-137	SL	B axis auxiliary position
138-141	SL	B axis velocity
142-145	SL (new size)	B axis torque
146-147	SW or UW ¹	B axis analog input
148	UB (new)	B Hall Input Status
149	UB	Reserved
150-153	SL (new)	B User defined variable (ZA)
154-155	UW	C axis status – see bit field map below
156	UB	C axis switches – see bit field map below
157	UB	C axis stop code
158-161	SL	C axis reference position
162-165	SL	C axis motor position

166-169	SL	C axis position error
170-173	SL	C axis auxiliary position
174-177	SL	C axis velocity
178-181	SL (new size)	C axis torque
182-183	SW or UW ¹	C axis analog input
184	UB (new)	C Hall Input Status
185	UB	Reserved
186-189	SL (new)	C User defined variable (ZA)
190-191	UW	D axis status – see bit field map below
192	UB	D axis switches – see bit field map below
193	UB	D axis stop code
194-197	SL	D axis reference position
198-201	SL	D axis motor position
202-205	SL	D axis position error
206-209	SL	D axis auxiliary position
210-213	SL	D axis velocity
214-217	SL (new size)	D axis torque
218-219	SW or UW ¹	D axis analog input
220	UB (new)	D Hall Input Status
221	UB	Reserved
222-225	SL (new)	D User defined variable (ZA)
226-227	UW	E axis status – see bit field map below
228	UB	E axis switches – see bit field map below
229	UB	E axis stop code
230-233	SL	E axis reference position
234-237	SL	E axis motor position
238-241	SL	E axis position error
242-245	SL	E axis auxiliary position
246-249	SL	E axis velocity
250-253	SL (new size)	E axis torque
254-255	SW or UW ¹	E axis analog input
256	UB (new)	E Hall Input Status
257	UB	Reserved
258-261	SL (new)	E User defined variable (ZA)
262-263	UW	F axis status – see bit field map below
264	UB	F axis switches – see bit field map below
265	UB	F axis stop code
266-269	SL	F axis reference position
270-273	SL	F axis motor position
274-277	SL	F axis position error
278-281	SL	F axis auxiliary position
282-285	SL	F axis velocity
286-289	SL (new size)	F axis torque
290-291	SW or UW ¹	F axis analog input

292	UB (new)	F Hall Input Status
293	UB	Reserved
294-297	SL (new)	F User defined variable (ZA)
298-299	UW	G axis status – see bit field map below
300	UB	G axis switches – see bit field map below
301	UB	G axis stop code
302-305	SL	G axis reference position
306-309	SL	G axis motor position
310-313	SL	G axis position error
314-317	SL	G axis auxiliary position
318-321	SL	G axis velocity
322-325	SL (new size)	G axis torque
326-327	SW or UW ¹	G axis analog input
328	UB (new)	G Hall Input Status
329	UB	Reserved
330-333	SL (new)	G User defined variable (ZA)
334-335	UW	H axis status – see bit field map below
336	UB	H axis switches – see bit field map below
337	UB	H axis stop code
338-341	SL	H axis reference position
342-345	SL	H axis motor position
346-349	SL	H axis position error
350-353	SL	H axis auxiliary position
354-357	SL	H axis velocity
358-361	SL (new size)	H axis torque
362-363	SW or UW ¹	H axis analog input
364	UB (new)	H Hall Input Status
365	UB	Reserved
366-369	SL (new)	H User defined variable (ZA)

1 Will be either a Signed Word or Unsigned Word depending upon AQ setting. See AQ in the Command Reference for more information.

Explanation Data Record Bit Fields

Header Information - Byte 0, 1 of Header:

BIT 15	BIT 14	BIT 13	BIT 12	BIT 11	BIT 10	BIT 9	BIT 8
1	N/A	N/A	N/A	N/A	I Block Present in Data Record	T Block Present in Data Record	S Block Present in Data Record
BIT 7	BIT 6	BIT 5	BIT 4	BIT 3	BIT 2	BIT 1	BIT 0
H Block Present in Data Record	G Block Present in Data Record	F Block Present in Data Record	E Block Present in Data Record	D Block Present in Data Record	C Block Present in Data Record	B Block Present in Data Record	A Block Present in Data Record

Bytes 2, 3 of Header:

Bytes 2 and 3 make a word which represents the Number of bytes in the data record, including the header.

Byte 2 is the low byte and byte 3 is the high byte

NOTE: The header information of the data records is formatted in little endian.

Thread Status (1 Byte)

BIT 7	BIT 6	BIT 5	BIT 4	BIT 3	BIT 2	BIT 1	BIT 0
Thread 7 Running	Thread 6 Running	Thread 5 Running	Thread 4 Running	Thread 3 Running	Thread 2 Running	Thread 1 Running	Thread 0 Running

Coordinated Motion Status for S or T Plane (2 Byte)

BIT 15	BIT 14	BIT 13	BIT 12	BIT 11	BIT 10	BIT 9	BIT 8
Move in Progress	N/A	N/A	N/A	N/A	N/A	N/A	N/A

BIT 7	BIT 6	BIT 5	BIT 4	BIT 3	BIT 2	BIT 1	BIT 0
N/A	N/A	Motion is slewing	Motion is stopping due to ST or Limit Switch	Motion is making final decel.	N/A	N/A	N/A

Axis Status (1 Word)

BIT 15	BIT 14	BIT 13	BIT 12	BIT 11	BIT 10	BIT 9	BIT 8
Move in Progress	Mode of Motion PA or PR	Mode of Motion PA only	(FE) Find Edge in Progress	Home (HM) in Progress	1 st Phase of HM complete	2 nd Phase of HM complete or FI command issued	Mode of Motion Coord. Motion

BIT 7	BIT 6	BIT 5	BIT 4	BIT 3	BIT 2	BIT 1	BIT 0
Negative Direction Move	Mode of Motion Contour	Motion is slewing	Motion is stopping due to ST of Limit Switch	Motion is making final decel.	Latch is armed	3 rd Phase of HM in Progress	Motor Off

Axis Switches (1 Byte)

BIT 7	BIT 6	BIT 5	BIT 4	BIT 3	BIT 2	BIT 1	BIT 0
Latch Occurred	State of Latch Input	N/A	N/A	State of Forward Limit	State of Reverse Limit	State of Home Input	Stepper Mode

Notes Regarding Velocity and Torque Information

The velocity information that is returned in the data record is 64 times larger than the value returned when using the command TV (Tell Velocity). See command reference for more information about TV.

The Torque information is represented as a number in the range of +/-32767. Maximum negative torque is -32767. Maximum positive torque is 32767. Zero torque is 0.

QZ Command

The QZ command can be very useful when using the QR command, since it provides information about the controller and the data record. The QZ command returns the following 4 bytes of information.

BYTE #	INFORMATION
0	Number of axes present
1	number of bytes in general block of data record
2	number of bytes in coordinate plane block of data record
3	Number of Bytes in each axis block of data record

Controller Response to Commands

Most DMC-40x0 instructions are represented by two characters followed by the appropriate parameters. Each instruction must be terminated by a carriage return or semicolon.

Instructions are sent in ASCII, and the DMC-40x0 decodes each ASCII character (one byte) one at a time. It takes approximately 0.05 msec for the controller to decode each command.

After the instruction is decoded, the DMC-40x0 returns a response to the port from which the command was generated. If the instruction was valid, the controller returns a colon (:) or a question mark (?) if the instruction was not valid. For example, the controller will respond to commands which are sent via the main RS-232 port back through the RS-232 port, and to commands which are sent via the Ethernet port back through the Ethernet port.

For instructions that return data, such as Tell Position (TP), the DMC-40x0 will return the data followed by a carriage return, line feed and : .

It is good practice to check for : after each command is sent to prevent errors. An echo function is provided to enable associating the DMC-40x0 response with the data sent. The echo is enabled by sending the command EO 1 to the controller.

Unsolicited Messages Generated by Controller

When the controller is executing a program, it may generate responses which will be sent via the main RS-232 port or Ethernet ports. This response could be generated as a result of messages using the MG command OR as a result of a command error. These responses are known as unsolicited messages since they are not generated as the direct response to a command.

Messages can be directed to a specific port using the specific Port arguments – see the MG and CF commands in the Command Reference. If the port is not explicitly given or the default is not changed with the CF command, unsolicited messages will be sent to the default port. The default port is the main serial port.

The controller has a special command, CW, which can affect the format of unsolicited messages. This command is used by Galil Software to differentiate response from the command line and unsolicited messages. The command, CW1 causes the controller to set the high bit of ASCII characters to 1 of all unsolicited characters. This may cause characters to appear garbled to some terminals. This function can be disabled by issuing the command, CW2. For more information, see the CW command in the Command Reference.

When handshaking is used (hardware and/or software handshaking) characters which are generated by the controller are placed in a FIFO buffer before they are sent out of the controller. The size of the RS-232 buffer is 512 bytes. When this buffer becomes full, the controller must either stop executing commands or ignore additional characters generated for output. The command CW,1 causes the controller to ignore all output from the controller while the FIFO is full. The command, CW ,0 causes the controller to stop executing new commands until more room is made available in the FIFO. This command can be very useful when hardware handshaking is being used and the communication line between controller and terminal will be disconnected. In this case, characters will continue to build up in the controller until the FIFO is full. For more information, see the CW command in the Command Reference.

GalilTools (Windows and Linux)

GalilTools is Galil's set of software tools for current Galil controllers. It is highly recommended for all first-time purchases of Galil controllers as it provides easy set-up, tuning and analysis. GalilTools replaces the WSDK Tuning software with an improved user-interface, real-time scopes and communications utilities.

The Galil Tools set contains the following tools: Scope, Editor, Terminal, Watch and Tuner, and a Communication Library for development with Galil Controllers.

The powerful Scope Tool is ideal for system analysis as it captures numerous types of data for each axis in real-time. Up to eight channels of data can be displayed at once, and additional real-time data can be viewed by changing the scope settings. This allows literally hundreds of parameters to be analyzed during a single data capture sequence. A rising or falling edge trigger feature is also included for precise synchronization of data.

The Program Editor Tool allows for easy writing of application programs and multiple editors to be open simultaneously.

The Terminal Tool provides a window for sending and receiving Galil commands and responses.

The Watch Tool displays controller parameters in a tabular format and includes units and scale factors for easy viewing.

The Tuning Tool helps select PID parameters for optimal servo performance.

The Communication Library provides function calls for communicating to Galil Controllers with C++ (Windows and Linux) and COM enabled languages such as VB C#, and Labview (Windows only).

GalilTools runs on Windows and Linux platforms as standard with other platforms available on request.

GalilTools-Lite is available at no charge and contains the Editor, Terminal, Watch and Communication Library tools only.

The latest version of GalilTools can be downloaded from the Galil website at:

<http://www.galilmc.com/products/software/galiltools.html>

For information on using GalilTools see the help menu in GalilTools, or the GalilTools user manual.

<http://www.galilmc.com/support/manuals/galiltools/index.html>

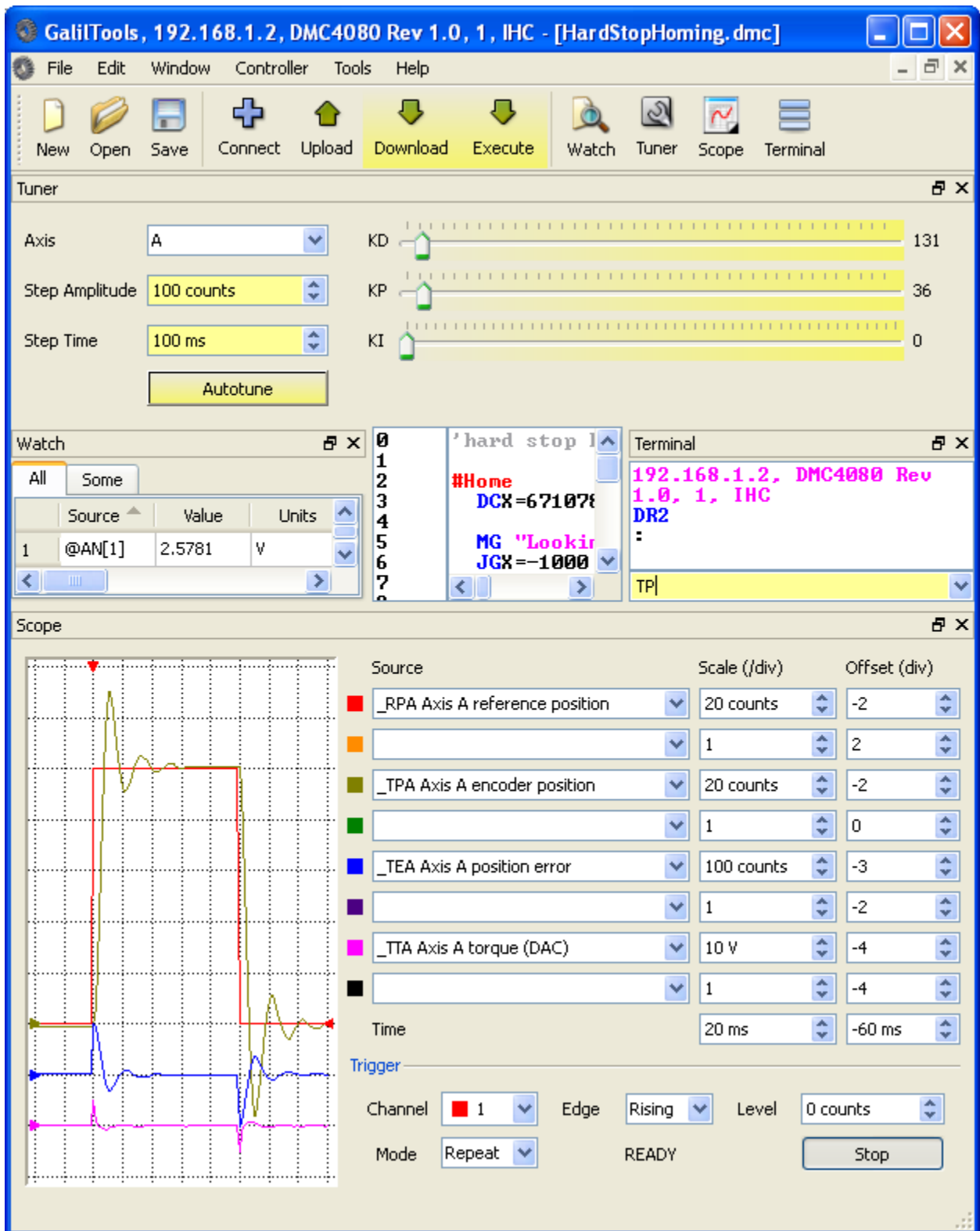

Figure 4.1 - GalilTools

Creating Custom Software Interfaces

Galil provides programming tools so that users can develop their own custom software interfaces to a Galil controller. These tools include the GalilTools Communication Library, ActiveX Toolkit, .NET API and DMCWin.

For new applications, Galil recommends the GalilTools Communication Libraries.

HelloGalil – Quick Start to PC programming

For programmers developing Windows applications that communicate with a Galil controller, the HelloGalil library of quick start projects immediately gets you communicating with the controller from the programming language of your choice. In the "Hello World" tradition, each project contains the bare minimum code to demonstrate communication to the controller and simply prints the controller's model and serial numbers to the screen:

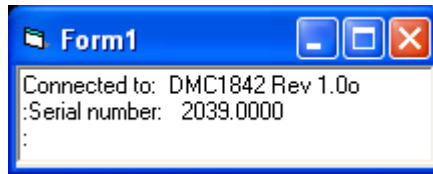

Figure 4.2. Sample program output

http://www.galilmc.com/support/hello_galil.html

GalilTools Communication Libraries

The GalilTools Communication Library (Galil class) provides methods for communication with a Galil motion controller over Ethernet, RS-232 or PCI buses. It consists of a native C++ Library and a similar COM interface which extends compatibility to Windows programming languages (e.g. VB, C#, etc).

A Galil object (usually referred to in sample code as "g") represents a single connection to a Galil controller.

For Ethernet controllers, which support more than one connection, multiple objects may be used to communicate with the controller. An example of multiple objects is one Galil object containing a TCP handle to a DMC-40x0 for commands and responses, and one Galil object containing a UDP handle for unsolicited messages from the controller. If [recordsStart\(\)](#) is used to begin the automatic data record function, the library will open an additional UDP handle to the controller (transparent to the user).

The library is conceptually divided into six categories:

1. Connecting and Disconnecting - functions to establish and discontinue communication with a controller.
2. Basic Communication - The most heavily used functions for command-and-response and unsolicited messages.
3. Programs - Downloading and uploading embedded programs.
4. Arrays - Downloading and uploading array data.
5. Advanced - Lesser-used calls.
6. Data Record - Access to the data record in both synchronous and asynchronous modes.

C++ Library (Windows and Linux)

Both Full and Lite versions of GalilTools ship with a native C++ communication library. The Linux version (libGalil.so) is compatible with g++ and the Windows version (Galil1.dll) with Visual C++ 2008. Contact Galil if another version of the C++ library is required. See the [getting started guide](#) and the hello.cpp example in /lib.

COM (Windows)

To further extend the language compatibility on Windows, a COM (Component Object Model) class built on top of the C++ library is also provided with Windows releases. This COM wrapper can be used in any language and IDE supporting COM (Visual Studio 2005, 2008, etc). The COM wrapper includes all of the functionality of the base C++ class. See the [getting started guide](#) and the hello.* examples in \lib for more info.

For more information on the GalilTools Communications Library, see the online user manual.

<http://www.galilmc.com/support/manuals/galiltools/library.html>

ActiveX Toolkit

Galil recommends the GalilTools Communication Library for all new applications.

Galil's ActiveX Toolkit is useful for the programmer who wants to easily create a custom operator interface to a Galil controller. The ActiveX Toolkit includes a collection of ready-made ActiveX COM controls for use with Visual Basic, Visual C++, Delphi, LabVIEW and other ActiveX compatible programming tools. The most common environment is Visual Basic 6, but Visual Basic.NET, Visual C++, Wonderware, LabVIEW and HPVEE have all been tested by Galil to work with the .OCX controls.

The ActiveX Toolkit can be purchased from Galil at:

<http://www.galilmc.com/buy/index.html>

The ActiveX toolkit can save many hours of programming time. Built-in dialog boxes are provided for quick parameter setup, selection of color, size, location and text. The toolkit controls are easy to use and provide context sensitive help, making it ideal for even the novice programmer.

ActiveX Toolkit Includes:

- a terminal control for sending commands and editing programs
- a polling window for displaying responses from the controller such as position and speed
- a storage scope control for plotting real time trajectories such as position versus time or X versus Y
- a send file control for sending contour data or vector DMC files
- a continuous array capture control for data collection, and for teach and playback
- a graphical display control for monitoring a 2-D motion path
- a diagnostics control for capturing current configurations
- a display control for input and output status
- a vector motion control for tool offsets and corner speed control

For more detailed information on the ActiveX Toolkit, please refer to the user manual at

<http://www.galilmc.com/support/manuals/activex.pdf>.

DMCWin Programmers Toolkit

Galil recommends the GalilTools Communication Library for all new applications.

DMCWin is a programmer's toolkit for C/C++ and Visual Basic users. The toolkit includes header files for the Galil communications API, as well as source code and examples for developing Windows® programs that communicate to Galil Controllers. The Galil communications API includes functions to send commands, download programs, download/upload arrays, access the data record, etc. For a complete list of all the functions, refer to the DMCWin user manual at:

<http://www.galilmc.com/support/manuals/dmcwin.pdf>.

This software package is free for download and is available at:

<http://www.galilmc.com/support/download.html>

Galil Communications API with C/C++

Galil recommends the GalilTools Communication Library for all new applications.

When programming in C/C++, the communications API can be used as included functions or through a class library. All Galil communications programs written in C must include the DMCCOM.H file and access the API functions through the declared routine calls. C++ programs can use the DMCCOM.H routines or use the class library defined in DMCWIN.H.

After installing DMCWin into the default directory, the DMCCOM.H header file is located in C:\Program Files\Galil\DMCWIN\INCLUDE. C++ programs that use the class library need the files DMCWIN.H and DMCWIN.CPP, which contain the class definitions and implementations respectively. These can be found in the C:\ProgramFiles\Galil\DMCWIN\CPP directory.

To link the application with the DLL's, the DMC32.lib file must be included in the project and is located at C:\Program Files\Galil\DMCWIN\LIB

Example: A simple console application that sends commands to the controller

To initiate communication, declare a variable of type HANDLEDMC (a long integer) and pass the address of that variable in the DMCOpen() function. If the DMCOpen() function is successful, the variable will contain the handle to the Galil controller, which is required for all subsequent function calls. The following simple example program written as a Visual C console application tells the controller to move the X axis 1000 encoder counts. Remember to add DMC32.LIB to your project prior to compiling.

```
#include <windows.h>
#include <dmccom.h>
long lRetCode;
HANDLEDMC hDmc;
HWND hWnd;
int main(void)
{
    // Connect to controller number 1
    lRetCode= DMCOpen(1, hWnd, &hDmc);
    if (rc == DMCNOERROR)
    {
        char szBuffer[64];
        // Move the X axis 1000 counts
        lRetCode = DMCCCommand(hDmc, "PR1000;BGX;", szBuffer,
sizeof(szBuffer));
        // Disconnect from controller number 1 as the last action
        lRetCode = DMCClose(hDmc);
    }
    return 0;
}
```

Galil Communications API with Visual Basic

Declare Functions

Galil recommends the GalilTools Communication Library for all new applications.

To use the Galil communications API functions, add the module file included in the C:\ProgramFiles\Galil\DMCWIN\VB directory named DMCCOM40.BAS. This module declares the routines making them available for the VB project. To add this file, select 'Add Module' from the 'Project' menu in VB5/6.

Sending Commands in VB

Most commands are sent to the controller with the DMCCCommand() function. This function allows any Galil command to be sent from VB to the controller. The DMCCCommand() function will return the response from the controller as a string. Before sending any commands the DMCOpen() function must be called. This function establishes communication with the controller and is called only once.

This example code illustrates the use of DMCOpen() and DMCCCommand(). A connection is made to controller #1 in the Galil registry upon launching the application. Then, the controller is sent the command 'TPX' whenever a command button is pressed. The response is then placed in a text box. When the application is closed, the controller is disconnected.

To use this example, start a new Visual Basic project, place a Text Box and a Command Button on a Form, add the DMCCOM40.BAS module, and type the following code:

```
Dim m_nController As Integer
Dim m_hDmc As Long
Dim m_nRetCode As Long
Dim m_nResponseLength As Long
Dim m_sResponse As String * 256

Private Sub Command1_Click()
    m_nRetCode = DMCCCommand(m_hDmc, "TPX", m_sResponse, m_nResponseLength)
    Text1.Text = Val(m_sResponse)
End Sub

Private Sub Form_Load()
    m_nResponseLength = 256
    m_nController = 1
    m_nRetCode = DMCOpen(m_nController, 0, m_hDmc)
End Sub

Private Sub Form_Unload(Cancel As Integer)
    m_nRetCode = DMCClose(m_hDmc)
End Sub
```

Where:

'm_nController' is the number for the controller in the Galil registry.

'm_hDmc' is the DMC handle used to identify the controller. It is returned by DMCOpen.

'm_nRetCode' is the return code for the routine.

'm_nResponseLength' is the response string length which must be set to the size of the response string.

'm_sResponse' is the string containing the controller response to the command.

DOS, and QNX tools

Galil offers unsupported code examples that demonstrate communications to the controller using the following operating systems.

DOS

DOS based utilities & Programming Libraries for Galil controllers, which includes a terminal, utilities to upload and download programs, and source code for BASIC and C programs. Download DMCDOS at :

<http://www.galilmc.com/support/download.html#dos>.

QNX

Galil offers sample drivers for ISA and PCI cards for the QNX 4.24 operating system. We also offer drivers and utilities for QNX 6.2 for PCI only. Download at:

<http://www.galilmc.com/support/download.html#linux>.

Linux

Galil now offers full support to Linux users through the GalilTools software package. For more information see the previous section on GalilTools, or visit the Galil website.

<http://www.galilmc.com/products/software/galiltools.html>

Chapter 5 Command Basics

Introduction

The DMC-40x0 provides over 100 commands for specifying motion and machine parameters. Commands are included to initiate action, interrogate status and configure the digital filter. These commands can be sent in ASCII or binary.

In ASCII, the DMC-40x0 instruction set is BASIC-like and easy to use. Instructions consist of two uppercase letters that correspond phonetically with the appropriate function. For example, the instruction BG begins motion, and ST stops the motion. In binary, commands are represented by a binary code ranging from 80 to FF.

ASCII commands can be sent "live" over the communications port for immediate execution by the DMC-40x0, or an entire group of commands can be downloaded into the DMC-40x0 memory for execution at a later time. Combining commands into groups for later execution is referred to as Applications Programming and is discussed in the following chapter. Binary commands cannot be used in Applications programming.

This section describes the DMC-40x0 instruction set and syntax. A summary of commands as well as a complete listing of all DMC-40x0 instructions is included in the *Command Reference*.

Command Syntax - ASCII

DMC-40x0 instructions are represented by two ASCII upper case characters followed by applicable arguments. A space may be inserted between the instruction and arguments. A semicolon or <return> is used to terminate the instruction for processing by the DMC-40x0 command interpreter.

NOTE: If you are using a Galil terminal program, commands will not be processed until an <return> command is given. This allows the user to separate many commands on a single line and not begin execution until the user gives the <return> command.

IMPORTANT: All DMC-40x0 commands are sent in upper case.

For example, the command

PR 4000 <return> Position relative

PR is the two character instruction for position relative. 4000 is the argument which represents the required position value in counts. The <return> terminates the instruction. The space between PR and 4000 is optional.

For specifying data for the A,B,C and D axes, commas are used to separate the axes. If no data is specified for an axis, a comma is still needed as shown in the examples below. If no data is specified for an axis, the previous value is maintained.

To view the current values for each command, type the command followed by a ? for each axis requested.

PR 1000	Specify A only as 1000
PR ,2000	Specify B only as 2000
PR ,,3000	Specify C only as 3000
PR,,,4000	Specify D only as 4000
PR 2000, 4000,6000, 8000	Specify A,B,C and D
PR ,8000,,9000	Specify B and D only
PR ?,?,?,?	Request A,B,C,D values
PR ,?	Request B value only

The DMC-40x0 provides an alternative method for specifying data. Here data is specified individually using a single axis specifier such as A, B, C or D. An equals sign is used to assign data to that axis. For example:

PRA=1000	Specify a position relative movement for the A axis of 1000
ACB=200000	Specify acceleration for the B axis as 200000

Instead of data, some commands request action to occur on an axis or group of axes. For example, ST AB stops motion on both the A and B axes. Commas are not required in this case since the particular axis is specified by the appropriate letter A, B, C or D. If no parameters follow the instruction, action will take place on all axes. Here are some examples of syntax for requesting action:

BG A	Begin A only
BG B	Begin B only
BG ABCD	Begin all axes
BG BD	Begin B and D only
BG	Begin all axes

4080

For controllers with 5 or more axes, the axes are referred to as A,B,C,D,E,F,G,H. The specifiers X,Y,Z,W and A,B,C,D may be used interchangeably.

BG ABCDEFGH	Begin all axes
BG D	Begin D only

Coordinated Motion with more than 1 axis

When requesting action for coordinated motion, the letter S or T is used to specify the coordinated motion. This allows for coordinated motion to be setup for two separate coordinate systems. Refer to the CA command in the Command Reference for more information on specifying a coordinate system. For example:

BG S	Begin coordinated sequence, S
BG TW	Begin coordinated sequence, T, and D axis

Command Syntax – Binary (advanced)

Some commands have an equivalent binary value. Binary communication mode can be executed about 20% faster than ASCII commands. Binary format can only be used when commands are sent from the PC and cannot be embedded in an application program.

Binary Command Format

All binary commands have a 4 byte header and is followed by data fields. The 4 bytes are specified in hexadecimal format.

Header Format:

Byte 1 specifies the command number between 80 to FF. The complete binary command number table is listed below.

Byte 2 specifies the # of bytes in each field as 0,1,2,4 or 6 as follows:

00	No data fields (i.e. SH or BG)
01	One byte per field
02	One word (2 bytes per field)
04	One long word (4 bytes) per field
06	Galil real format (4 bytes integer and 2 bytes fraction)

Byte 3 specifies whether the command applies to a coordinated move as follows:

00	No coordinated motion movement
01	Coordinated motion movement

For example, the command STS designates motion to stop on a vector move, S coordinate system. The third byte for the equivalent binary command would be 01.

Byte 4 specifies the axis # or data field as follows

Bit 7 = H axis or 8 th data field
Bit 6 = G axis or 7 th data field
Bit 5 = F axis or 6 th data field
Bit 4 = E axis or 5 th data field
Bit 3 = D axis or 4 th data field
Bit 2 = C axis or 3 rd data field
Bit 1 = B axis or 2 nd data field
Bit 0 = A axis or 1 st data field

Data fields Format

Data fields must be consistent with the format byte and the axes byte. For example, the command PR 1000., -500 would be :

A7 02 00 05 03 E8 FE 0C

where A7 is the command number for PR

02 specifies 2 bytes for each data field

00 S is not active for PR

05 specifies bit 0 is active for A axis and bit 2 is active for C axis ($2^0 + 2^2=5$)

03 E8 represents 1000

FE OC represents -500

Example

The command ST XYZS would be :

A1 00 01 07

where A1 is the command number for ST

00 specifies 0 data fields

01 specifies stop the coordinated axes S

07 specifies stop X (bit 0), Y (bit 1) and Z (bit 2) $2^0+2^1+2^2=7$

Binary command table

Command	No.	Command	No.	Command	No.
reserved	80	reserved	ab	reserved	d6
KP	81	reserved	ac	reserved	d7
KI	82	reserved	ad	RP	d8
KD	83	reserved	ae	TP	d9
DV	84	reserved	af	TE	da
AF	85	LM	b0	TD	db
KS	86	LI	b1	TV	dc
PL	87	VP	b2	RL	dd
ER	88	CR	b3	TT	de
IL	89	TN	b4	TS	df
TL	8a	LE, VE	b5	TI	e0
MT	8b	reserved	b6	SC	e1
CE	8c	VA	b7	reserved	e2
OE	8d	VD	b8	reserved	e3
FL	8e	VS	b9	reserved	e4
BL	8f	VR	ba	TM	e5
AC	90	reserved	bb	CN	e6
DC	91	reserved	bc	LZ	e7
SP	92	CM	bd	OP	e8
IT	93	CD	be	OB	e9
FA	94	DT	bf	SB	ea
FV	95	ET	c0	CB	eb
GR	96	EM	c1	II	ec
DP	97	EP	c2	EI	ed
DE	98	EG	c3	AL	ee

OF	99	EB	c4	reserved	ef
GM	9a	EQ	c5	reserved	f0
reserved	9b	EC	c6	reserved	f1
reserved	9c	reserved	c7	reserved	f2
reserved	9d	AM	c8	reserved	f3
reserved	9e	MC	c9	reserved	f4
reserved	9f	TW	ca	reserved	f5
BG	a0	MF	cb	reserved	f6
ST	a1	MR	cc	reserved	f7
AB	a2	AD	cd	reserved	f8
HM	a3	AP	ce	reserved	f9
FE	a4	AR	cf	reserved	fa
FI	a5	AS	d0	reserved	fb
PA	a6	AI	d1	reserved	fc
PR	a7	AT	d2	reserved	fd
JG	a8	WT	d3	reserved	fe
MO	a9	reserved	d4	reserved	ff
SH	aa	reserved	d5		

Controller Response to DATA

The DMC-40x0 returns a : for valid commands and a ? for invalid commands.

For example, if the command BG is sent in lower case, the DMC-40x0 will return a ?.

```

:bg <return>          invalid command, lower case
?                      DMC-40x0 returns a ?

```

When the controller receives an invalid command the user can request the error code. The error code will specify the reason for the invalid command response. To request the error code type the command TC1. For example:

```

?TC1 <return>        Tell Code command
1 Unrecognized        Returned response

```

There are many reasons for receiving an invalid command response. The most common reasons are: unrecognized command (such as typographical entry or lower case), command given at improper time (such as during motion), or a command out of range (such as exceeding maximum speed). A complete listing of all codes is listed in the TC command in the Command Reference section.

Interrogating the Controller

Interrogation Commands

The DMC-40x0 has a set of commands that directly interrogate the controller. When the command is entered, the requested data is returned in decimal format on the next line followed by a carriage return and line feed. The format of the returned data can be changed using the Position Format (PF), Variable Format (VF) and Leading Zeros (LZ) command. See [Chapter 7](#) and the Command Reference.

Summary of Interrogation Commands

RP	Report Command Position
RL	Report Latch
^R ^V	Firmware Revision Information
SC	Stop Code
TB	Tell Status
TC	Tell Error Code
TD	Tell Dual Encoder
TE	Tell Error
TI	Tell Input
TP	Tell Position
TR	Trace
TS	Tell Switches
TT	Tell Torque
TV	Tell Velocity

For example, the following example illustrates how to display the current position of the X axis:

```
TP A <return>      Tell position A
0                  Controllers Response
TP AB <return>     Tell position A and B
0,0                Controllers Response
```

Interrogating Current Commanded Values.

Most commands can be interrogated by using a question mark (?) as the axis specifier. Type the command followed by a ? for each axis requested.

```
PR ?,?,? ,?      Request A,B,C,D values
PR ,?             Request B value only
```

The controller can also be interrogated with operands.

Operands

Most DMC-40x0 commands have corresponding operands that can be used for interrogation. Operands must be used inside of valid DMC expressions. For example, to display the value of an operand, the user could use the command:

MG 'operand' where 'operand' is a valid DMC operand

All of the command operands begin with the underscore character (_). For example, the value of the current position on the A axis can be assigned to the variable 'V' with the command:

```
V=_TPA
```

The Command Reference denotes all commands which have an equivalent operand as "Used as an Operand". Also, see description of operands in [Chapter 7](#).

Command Summary

For a complete command summary, see *Command Reference* manual.

Chapter 6 Programming Motion

Overview

The DMC-40x0 provides several modes of motion, including independent positioning and jogging, coordinated motion, electronic cam motion, and electronic gearing. Each one of these modes is discussed in the following sections.

The DMC-4010 are single axis controllers and use X-axis motion only. Likewise, the DMC-4020 use X and Y, the DMC-4030 use X,Y, and Z, and the DMC-4040 use X,Y,Z, and W. The DMC-4050 use A,B,C,D, and E. The DMC-4060 use A,B,C,D,E, and F. The DMC-4070 use A,B,C,D,E,F, and G. The DMC-4080 use the axes A,B,C,D,E,F,G, and H.

The example applications described below will help guide you to the appropriate mode of motion.

4080

For controllers with 5 or more axes, the specifiers, ABCDEFGH, are used. XYZ and W may be interchanged with ABCD.

EXAMPLE APPLICATION	MODE OF MOTION	COMMANDS
Absolute or relative positioning where each axis is independent and follows prescribed velocity profile.	Independent Axis Positioning	PA,PR SP,AC,DC
Velocity control where no final endpoint is prescribed. Motion stops on Stop command.	Independent Jogging	JG AC,DC ST
Absolute positioning mode where absolute position targets may be sent to the controller while the axis is in motion.	Position Tracking	PA, PT SP AC, DC
Motion Path described as incremental position points versus time.	Contour Mode	CM CD DT
2,3 or 4 axis coordinated motion where path is described by linear segments.	Linear Interpolation	LM LI, LE VS,VR VA,VD

2-D motion path consisting of arc segments and linear segments, such as engraving or quilting.	Coordinated Motion	VM VP CR VS,VR VA,VD VE
Third axis must remain tangent to 2-D motion path, such as knife cutting.	Coordinated motion with tangent axis specified	VM VP CR VS,VA,VD TN VE
Electronic gearing where slave axes are scaled to master axis which can move in both directions.	Electronic Gearing	GA GD _GP GR GM (if gantry)
Master/slave where slave axes must follow a master such as conveyer speed.	Electronic Gearing	GA GD _GP GR
Moving along arbitrary profiles or mathematically prescribed profiles such as sine or cosine trajectories.	Contour Mode	CM CD DT
Teaching or Record and Play Back	Contour Mode with Automatic Array Capture	CM CD DT RA RD RC
Backlash Correction	Dual Loop	DV
Following a trajectory based on a master encoder position	Electronic Cam	EA EM EP ET EB EG EQ
Smooth motion while operating in independent axis positioning	Independent Motion Smoothing	IT
Smooth motion while operating in vector or linear interpolation positioning	Vector Smoothing	IT
Smooth motion while operating with stepper motors	Stepper Motor Smoothing	KS
Gantry - two axes are coupled by gantry	Gantry Mode	GR GM

Independent Axis Positioning

In this mode, motion between the specified axes is independent, and each axis follows its own profile. The user specifies the desired absolute position (PA) or relative position (PR), slew speed (SP), acceleration ramp (AC), and deceleration ramp (DC), for each axis. On begin (BG), the DMC-40x0 profiler generates the corresponding trapezoidal or triangular velocity profile and position trajectory. The controller determines a new command position along the trajectory every sample period until the specified profile is complete. Motion is complete when the last position command is sent by the DMC-40x0 profiler. Note: The actual motor motion may not be complete when the profile has been completed, however, the next motion command may be specified.

The Begin (BG) command can be issued for all axes either simultaneously or independently. XYZ or W axis specifiers are required to select the axes for motion. When no axes are specified, this causes motion to begin on all axes.

The speed (SP) and the acceleration (AC) can be changed at any time during motion, however, the deceleration (DC) and position (PR or PA) cannot be changed until motion is complete. Remember, motion is complete when the profiler is finished, not when the actual motor is in position. The Stop command (ST) can be issued at any time to decelerate the motor to a stop before it reaches its final position.

An incremental position movement (IP) may be specified during motion as long as the additional move is in the same direction. Here, the user specifies the desired position increment, n. The new target is equal to the old target plus the increment, n. Upon receiving the IP command, a revised profile will be generated for motion towards the new end position. The IP command does not require a begin. Note: If the motor is not moving, the IP command is equivalent to the PR and BG command combination.

Command Summary - Independent Axis

COMMAND	DESCRIPTION
PR x,y,z,w	Specifies relative distance
PA x,y,z,w	Specifies absolute position
SP x,y,z,w	Specifies slew speed
AC x,y,z,w	Specifies acceleration rate
DC x,y,z,w	Specifies deceleration rate
BG XYZW	Starts motion
ST XYZW	Stops motion before end of move
IP x,y,z,w	Changes position target
IT x,y,z,w	Time constant for independent motion smoothing
AM XYZW	Trippoint for profiler complete
MC XYZW	Trippoint for "in position"

The lower case specifiers (x,y,z,w) represent position values for each axis.

The DMC-40x0 also allows use of single axis specifiers such as PRY=2000

Operand Summary - Independent Axis

OPERAND	DESCRIPTION
_ACx	Return acceleration rate for the axis specified by 'x'
_DCx	Return deceleration rate for the axis specified by 'x'

_SPx	Returns the speed for the axis specified by 'x'
_PAx	Returns current destination if 'x' axis is moving, otherwise returns the current commanded position if in a move.
_PRx	Returns current incremental distance specified for the 'x' axis

Example - Absolute Position Movement

```

PA 10000,20000      Specify absolute X,Y position
AC 1000000,1000000  Acceleration for X,Y
DC 1000000,1000000  Deceleration for X,Y
SP 50000,30000      Speeds for X,Y
BG XY               Begin motion

```

Example - Multiple Move Sequence

Required Motion Profiles:

```

X-Axis  500 counts      Position
         20000 count/sec  Speed
         500000 counts/sec2  Acceleration
Y-Axis  1000 counts     Position
         10000 count/sec   Speed
         500000 counts/sec2  Acceleration
Z-Axis  100 counts      Position
         5000 counts/sec   Speed
         500000 counts/sec  Acceleration

```

This example will specify a relative position movement on X, Y and Z axes. The movement on each axis will be separated by 20 msec. Fig. 6.0 shows the velocity profiles for the X,Y and Z axis.

```

#A          Begin Program
PR 2000,500,100  Specify relative position movement of 1000, 500 and 100 counts for X,Y and Z axes.
SP 20000,10000,5000  Specify speed of 20000, 10000, and 5000 counts / sec
AC 500000,500000,500000  Specify acceleration of 500000 counts / sec2 for all axes
DC 500000,500000,500000  Specify deceleration of 500000 counts / sec2 for all axes
BG X          Begin motion on the X axis
WT 20         Wait 20 msec
BG Y          Begin motion on the Y axis
WT 20         Wait 20 msec
BG Z          Begin motion on Z axis
EN           End Program

```

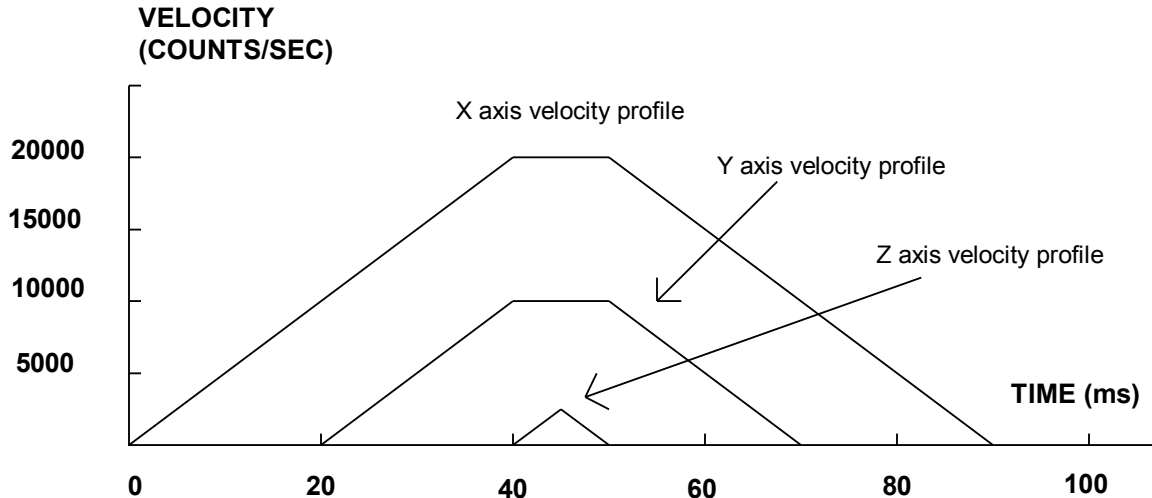



Figure 6.1: Velocity Profiles of XYZ

Notes on Figure 6.1: The X and Y axis have a ‘trapezoidal’ velocity profile, while the Z axis has a ‘triangular’ velocity profile. The X and Y axes accelerate to the specified speed, move at this constant speed, and then decelerate such that the final position agrees with the command position, PR. The Z axis accelerates, but before the specified speed is achieved, must begin deceleration such that the axis will stop at the commanded position. All 3 axes have the same acceleration and deceleration rate, hence, the slope of the rising and falling edges of all 3 velocity profiles are the same.

Independent Jogging

The jog mode of motion is very flexible because speed, direction and acceleration can be changed during motion. The user specifies the jog speed (JG), acceleration (AC), and the deceleration (DC) rate for each axis. The direction of motion is specified by the sign of the JG parameters. When the begin command is given (BG), the motor accelerates up to speed and continues to jog at that speed until a new speed or stop (ST) command is issued. If the jog speed is changed during motion, the controller will make an accelerated (or decelerated) change to the new speed.

An instant change to the motor position can be made with the use of the IP command. Upon receiving this command, the controller commands the motor to a position which is equal to the specified increment plus the current position. This command is useful when trying to synchronize the position of two motors while they are moving.

Note that the controller operates as a closed-loop position controller while in the jog mode. The DMC-40x0 converts the velocity profile into a position trajectory and a new position target is generated every sample period. This method of control results in precise speed regulation with phase lock accuracy.

Command Summary - Jogging

COMMAND	DESCRIPTION
AC x,y,z,w	Specifies acceleration rate
BG XYZW	Begins motion
DC x,y,z,w	Specifies deceleration rate
IP x,y,z,w	Increments position instantly
IT x,y,z,w	Time constant for independent motion smoothing
JG +/-x,y,z,w	Specifies jog speed and direction
ST XYZW	Stops motion

Parameters can be set with individual axes specifiers such as JGY=2000 (set jog speed for Y axis to 2000).

Operand Summary - Independent Axis

OPERAND	DESCRIPTION
_ACx	Return acceleration rate for the axis specified by 'x'
_DCx	Return deceleration rate for the axis specified by 'x'
_SPx	Returns the jog speed for the axis specified by 'x'
_TVx	Returns the actual velocity of the axis specified by 'x' (averaged over 0.25 sec)

Example - Jog in X only

Jog X motor at 50000 count/s. After X motor is at its jog speed, begin jogging Z in reverse direction at 25000 count/s.

```
#A
AC 20000,,20000      Specify X,Z acceleration of 20000 cts / sec
DC 20000,,20000      Specify X,Z deceleration of 20000 cts / sec
JG 50000,,-25000     Specify jog speed and direction for X and Z axis
BG X                  Begin X motion
AS X                  Wait until X is at speed
BG Z                  Begin Z motion
EN
```

Example - Joystick Jogging

The jog speed can also be changed using an analog input such as a joystick. Assume that for a 10 Volt input the speed must be 50000 counts/sec.

```
#JOY                  Label
JG0                    Set in Jog Mode
BGX                    Begin motion
#B                      Label for loop
V1 =@AN[1]             Read analog input
VEL=V1*50000/10        Compute speed
JG VEL                 Change JG speed
JP #B                  Loop
```

Position Tracking

The Galil controller may be placed in the position tracking mode to support changing the target of an absolute position move on the fly. New targets may be given in the same direction or the opposite direction of the current position target. The controller will then calculate a new trajectory based upon the new target and the acceleration, deceleration, and speed parameters that have been set. The motion profile in this mode is trapezoidal. There is not a set limit governing the rate at which the end point may be changed, however at the standard TM rate, the controller updates the position information at the rate of 1msec. The controller generates a profiled point every other sample, and linearly interpolates one sample between each profiled point. Some examples of applications that may use this mode are satellite tracking, missile tracking, random pattern polishing of mirrors or lenses, or any application that requires the ability to change the endpoint without completing the previous move.

The PA command is typically used to command an axis or multiple axes to a specific absolute position. For some applications such as tracking an object, the controller must proceed towards a target and have the ability to change

the target during the move. In a tracking application, this could occur at any time during the move or at regularly scheduled intervals. For example if a robot was designed to follow a moving object at a specified distance and the path of the object wasn't known the robot would be required to constantly monitor the motion of the object that it was following. To remain within a specified distance it would also need to constantly update the position target it is moving towards. Galil motion controllers support this type of motion with the position tracking mode. This mode will allow scheduled or random updates to the current position target on the fly. Based on the new target the controller will either continue in the direction it is heading, change the direction it is moving, or decelerate to a stop.

The position tracking mode shouldn't be confused with the contour mode. The contour mode allows the user to generate custom profiles by updating the reference position at a specific time rate. In this mode, the position can be updated randomly or at a fixed time rate, but the velocity profile will always be trapezoidal with the parameters specified by AC, DC, and SP. Updating the position target at a specific rate will not allow the user to create a custom profile.

The following example will demonstrate the possible different motions that may be commanded by the controller in the position tracking mode. In this example, there is a host program that will generate the absolute position targets. The absolute target is determined based on the current information the host program has gathered on the object that it is tracking. The position tracking mode does allow for all of the axes on the controller to be in this mode, but for the sake of discussion, it is assumed that the robot is tracking only in the X dimension.

The controller must be placed in the position tracking mode to allow on the fly absolute position changes. This is performed with the PT command. To place the X axis in this mode, the host would issue PT1 to the controller if both X and Y axes were desired the command would be PT 1,1. The next step is to begin issuing PA command to the controller. The BG command isn't required in this mode, the SP, AC, and DC commands determine the shape of the trapezoidal velocity profile that the controller will use.

Example Motion 1: The host program determines that the first target for the controller to move to is located at 5000 encoder counts. The acceleration and deceleration should be set to 150,000 cts/sec² and the velocity is set to 50,000 cts/sec. The command sequence to perform this is listed below.

Command	Description
PT1	Place the X axis in Position tracking mode
AC150000	Set the X axis acceleration to 150000 cts/sec ²
DC150000	Set the X axis deceleration to 150000 cts/sec ²
SP50000	Set the X axis speed to 50000 cts/sec
PA5000	Command the X axis to absolute position 5000 encoder counts

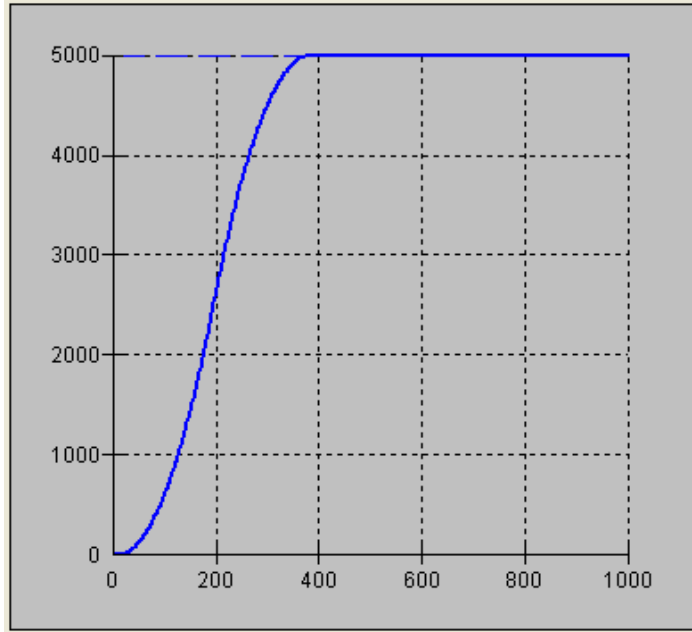

Figure 6.2: Position vs. Time (msec) Motion 1

Example - Motion 2:

The previous step showed the plot if the motion continued all the way to 5000, however partway through the motion, the object that was being tracked changed direction, so the host program determined that the actual target position should be 2000 cts at that time. Figure 6.2 shows what the position profile would look like if the move was allowed to complete to 5000 cts. The position was modified when the robot was at a position of 4200 cts. Note that the robot actually travels to a distance of almost 5000 cts before it turns around. This is a function of the deceleration rate set by the DC command. When a direction change is commanded, the controller decelerates at the rate specified by the DC command. The controller then ramps the velocity in up to the value set with SP in the opposite direction traveling to the new specified absolute position. In Figure 6.3 the velocity profile is triangular because the controller doesn't have sufficient time to reach the set speed of 50000 cts/sec before it is commanded to change direction.

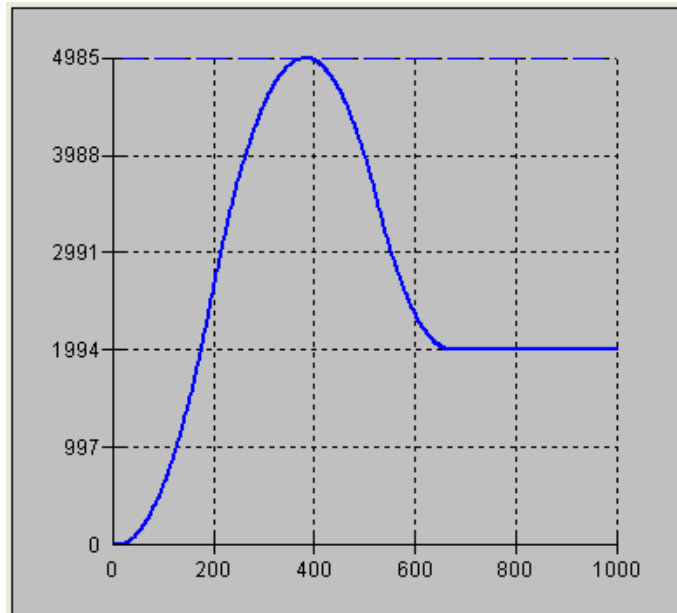

Figure 6.3: Position vs. Time (msec) Motion 2

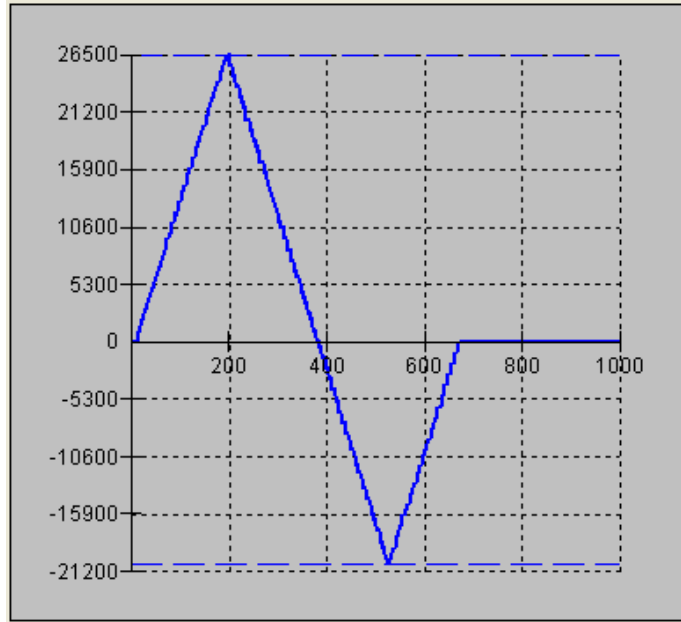

Figure 6.4: Velocity vs. Time (msec) Motion 2

Example Motion 4

In this motion, the host program commands the controller to begin motion towards position 5000, changes the target to -2000, and then changes it again to 8000. Figure 6.5 shows the plot of position vs. time, Figure 6.6 plots velocity vs. time, and Figure 6.7 demonstrates the use of motion smoothing (IT) on the velocity profile in this mode. The jerk in the system is also affected by the values set for AC and DC.

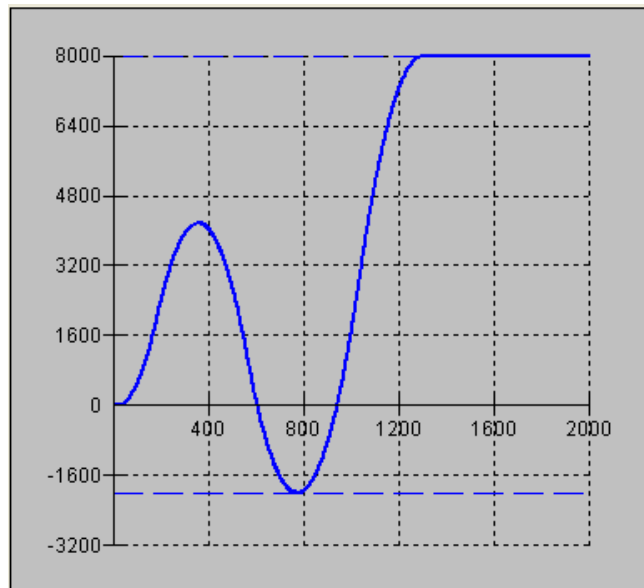

Figure 6.5: Position vs. Time (msec) Motion 4

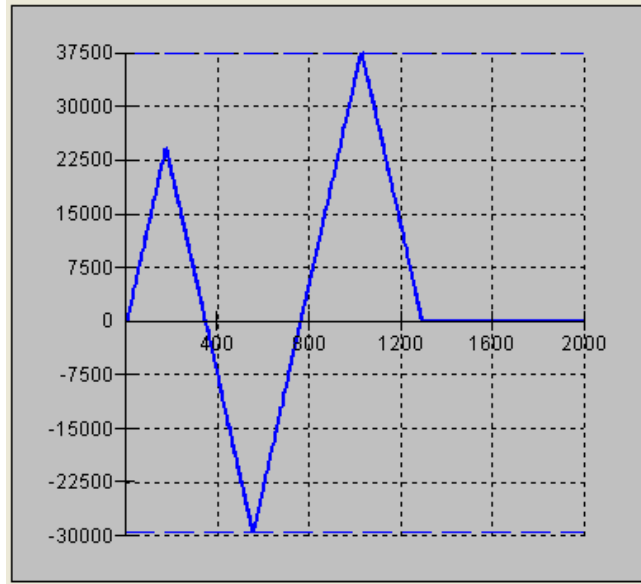

Figure 6.6: Velocity vs. Time Motion 4

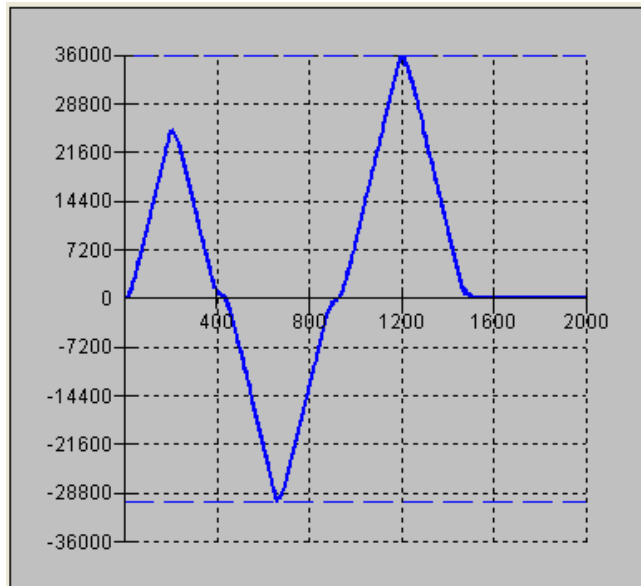

Figure 6.7: Velocity cts/sec vs. Time (msec) with IT

Note the controller treats the point where the velocity passes through zero as the end of one move, and the beginning of another move. IT is allowed, however it will introduce some time delay.

Trip Points

Most trip points are valid for use while in the position tracking mode. There are a few exceptions to this; the AM and MC commands may not be used while in this mode. It is recommended that MF, MR, or AP be used, as they involve motion in a specified direction, or the passing of a specific absolute position.

Command Summary – Position Tracking Mode

COMMAND	DESCRIPTION
AC n,n,n,n,n,n,n	Acceleration settings for the specified axes
AP n,n,n,n,n,n,n	Trip point that holds up program execution until an absolute position has been reached
DC n,n,n,n,n,n,n	Deceleration settings for the specified axes
MF n,n,n,n,n,n,n	Trip point to hold up program execution until n number of counts have passed in the forward direction. Only one axis at a time may be specified.
MR n,n,n,n,n,n,n	Trip point to hold up program execution until n number of counts have passed in the reverse direction. Only one axis at a time may be specified.
PT n,n,n,n,n,n,n	Command used to enter and exit the Trajectory Modification Mode
PA n,n,n,n,n,n,n	Command Used to specify the absolute position target
SP n,n,n,n,n,n,n	Speed settings for the specified axes

Linear Interpolation Mode

The DMC-40x0 provides a linear interpolation mode for 2 or more axes. In linear interpolation mode, motion between the axes is coordinated to maintain the prescribed vector speed, acceleration, and deceleration along the specified path. The motion path is described in terms of incremental distances for each axis. An unlimited number of incremental segments may be given in a continuous move sequence, making the linear interpolation mode ideal for following a piece-wise linear path. There is no limit to the total move length.

The LM command selects the Linear Interpolation mode and axes for interpolation. For example, LM YZ selects only the Y and Z axes for linear interpolation.

When using the linear interpolation mode, the LM command only needs to be specified once unless the axes for linear interpolation change.

Specifying Linear Segments

The command LI x,y,z,w or LI a,b,c,d,e,f,g,h specifies the incremental move distance for each axis. This means motion is prescribed with respect to the current axis position. Up to 511 incremental move segments may be given prior to the Begin Sequence (BGS) command. Once motion has begun, additional LI segments may be sent to the controller.

The clear sequence (CS) command can be used to remove LI segments stored in the buffer prior to the start of the motion. To stop the motion, use the instructions STS or AB. The command, ST, causes a decelerated stop. The command, AB, causes an instantaneous stop and aborts the program, and the command AB1 aborts the motion only.

The Linear End (LE) command must be used to specify the end of a linear move sequence. This command tells the controller to decelerate to a stop following the last LI command. If an LE command is not given, an Abort AB1 must be used to abort the motion sequence.

It is the responsibility of the user to keep enough LI segments in the DMC-40x0 sequence buffer to ensure continuous motion. If the controller receives no additional LI segments and no LE command, the controller will stop motion instantly at the last vector. There will be no controlled deceleration. LM? or _LM returns the available spaces for LI segments that can be sent to the buffer. 511 returned means the buffer is empty and 511 LI segments can be sent. A zero means the buffer is full and no additional segments can be sent. As long as the buffer is not full, additional LI segments can be sent at PC bus speeds.

The instruction _CS returns the segment counter. As the segments are processed, _CS increases, starting at zero. This function allows the host computer to determine which segment is being processed.

Additional Commands

The commands VS n, VA n, and VD n are used to specify the vector speed, acceleration and deceleration. The DMC-40x0 computes the vector speed based on the axes specified in the LM mode. For example, LM XYZ designates linear interpolation for the X,Y and Z axes. The vector speed for this example would be computed using the equation:

$VS2=XS2+YS2+ZS2$, where XS, YS and ZS are the speed of the X,Y and Z axes.

The controller always uses the axis specifications from LM, not LI, to compute the speed.

IT is used to set the S-curve smoothing constant for coordinated moves. The command AV n is the 'After Vector' trippoint, which halts program execution until the vector distance of n has been reached.

An Example of Linear Interpolation Motion:

#LMOVE	label
DP 0,0	Define position of X and Y axes to be 0
LMXY	Define linear mode between X and Y axes.
LI 5000,0	Specify first linear segment
LI 0,5000	Specify second linear segment
LE	End linear segments
VS 4000	Specify vector speed
BGS	Begin motion sequence
AV 4000	Set trippoint to wait until vector distance of 4000 is reached
VS 1000	Change vector speed
AV 5000	Set trippoint to wait until vector distance of 5000 is reached
VS 4000	Change vector speed
EN	Program end

In this example, the XY system is required to perform a 90° turn. In order to slow the speed around the corner, we use the AV 4000 trippoint, which slows the speed to 1000 count/s. Once the motors reach the corner, the speed is increased back to 4000 cts / s.

Specifying Vector Speed for Each Segment

The instruction VS has an immediate effect and, therefore, must be given at the required time. In some applications, such as CNC, it is necessary to attach various speeds to different motion segments. This can be done by two functions: < n and > m

For example: LI x,y,z,w < n > m

The first command, < n, is equivalent to commanding VS_n at the start of the given segment and will cause an acceleration toward the new commanded speeds, subjects to the other constraints.

The second function, > m, requires the vector speed to reach the value m at the end of the segment. Note that the function > m may start the deceleration within the given segment or during previous segments, as needed to meet the final speed requirement, under the given values of VA and VD.

Note, however, that the controller works with one > m command at a time. As a consequence, one function may be masked by another. For example, if the function >100000 is followed by >5000, and the distance for deceleration is not sufficient, the second condition will not be met. The controller will attempt to lower the speed to 5000, but will reach that at a different point.

As an example, consider the following program.

#ALT	Label for alternative program
DP 0,0	Define Position of X and Y axis to be 0
LMXY	Define linear mode between X and Y axes.
LI 4000,0 <4000 >1000	Specify first linear segment with a vector speed of 4000 and end speed 1000

```

LI 1000,1000 < 4000      Specify second linear segment with a vector speed of 4000 and end speed
>1000                    1000
LI 0,5000 < 4000        Specify third linear segment with a vector speed of 4000 and end speed 1000
>1000
LE                        End linear segments
BGS                       Begin motion sequence
EN                        Program end

```

Changing Feed Rate:

The command VR n allows the feed rate, VS, to be scaled between 0 and 10 with a resolution of .0001. This command takes effect immediately and causes VS to be scaled. VR also applies when the vector speed is specified with the '<' operator. This is a useful feature for feed rate override. VR does not ratio the accelerations. For example, VR .5 results in the specification VS 2000 to be divided in half.

Command Summary - Linear Interpolation

COMMAND	DESCRIPTION
LM xyzw LM abcdefgh	Specify axes for linear interpolation (same) controllers with 5 or more axes
LM?	Returns number of available spaces for linear segments in DMC-40x0 sequence buffer. Zero means buffer full. 511 means buffer empty.
LI x,y,z,w < n LI a,b,c,d,e,f,g,h < n	Specify incremental distances relative to current position, and assign vector speed n.
VS n	Specify vector speed
VA n	Specify vector acceleration
VD n	Specify vector deceleration
VR n	Specify the vector speed ratio
BGS	Begin Linear Sequence
CS	Clear sequence
LE	Linear End- Required at end of LI command sequence
LE?	Returns the length of the vector (resets after 2147483647)
AMS	Trippoint for After Sequence complete
AV n	Trippoint for After Relative Vector distance, n
IT	S curve smoothing constant for vector moves

Operand Summary - Linear Interpolation

OPERAND	DESCRIPTION
_AV	Return distance traveled
_CS	Segment counter - returns number of the segment in the sequence, starting at zero.
_LE	Returns length of vector (resets after 2147483647)
_LM	Returns number of available spaces for linear segments in DMC-40x0 sequence buffer. Zero means buffer full. 511 means buffer empty.
_VPm	Return the absolute coordinate of the last data point along the trajectory. (m=X,Y,Z or W or A,B,C,D,E,F,G or H)

To illustrate the ability to interrogate the motion status, consider the first motion segment of our example, #LMOVE, where the X axis moves toward the point X=5000. Suppose that when X=3000, the controller is interrogated using the command 'MG _AV'. The returned value will be 3000. The value of _CS, _VPX and _VPY will be zero.

Now suppose that the interrogation is repeated at the second segment when Y=2000. The value of _AV at this point is 7000, _CS equals 1, _VPX=5000 and _VPY=0.

Example - Linear Move

Make a coordinated linear move in the ZW plane. Move to coordinates 40000,30000 counts at a vector speed of 100000 counts/sec and vector acceleration of 1000000 counts/sec².

LM ZW	Specify axes for linear interpolation
LI,,40000,30000	Specify ZW distances
LE	Specify end move
VS 100000	Specify vector speed
VA 1000000	Specify vector acceleration
VD 1000000	Specify vector deceleration
BGS	Begin sequence

Note that the above program specifies the vector speed, VS, and not the actual axis speeds VZ and VW. The axis speeds are determined by the controller from:

$$VS = \sqrt{VZ^2 + VW^2}$$

The result is shown in Figure 6.8: Linear Interpolation.

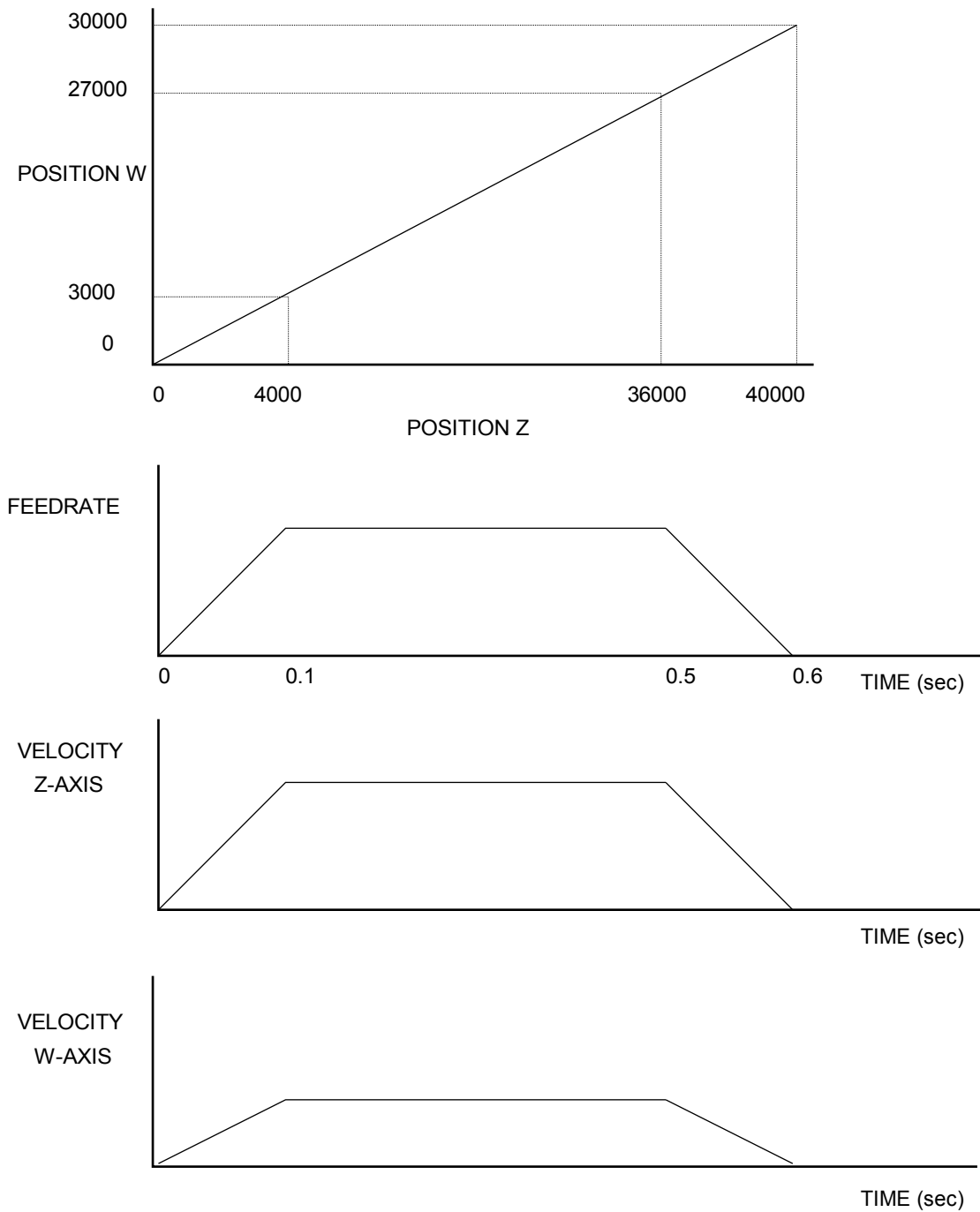

Figure 6.8: Linear Interpolation

Example - Multiple Moves

This example makes a coordinated linear move in the XY plane. The Arrays VX and VY are used to store 750 incremental distances which are filled by the program #LOAD.

```

#LOAD                               Load Program
DM VX [750],VY [750]               Define Array
COUNT=0                             Initialize Counter

```

N=0	Initialize position increment
#LOOP	LOOP
VX [COUNT]=N	Fill Array VX
VY [COUNT]=N	Fill Array VY
N=N+10	Increment position
COUNT=COUNT+1	Increment counter
JP #LOOP,COUNT<750	Loop if array not full
#A	Label
LM XY	Specify linear mode for XY
COUNT=0	Initialize array counter
#LOOP2;JP#LOOP2,_LM=0	If sequence buffer full, wait
JS#C,COUNT=500	Begin motion on 500 th segment
LI VX[COUNT],VY[COUNT]	Specify linear segment
COUNT=COUNT+1	Increment array counter
JP #LOOP2,COUNT<750	Repeat until array done
LE	End Linear Move
AMS	After Move sequence done
MG "DONE"	Send Message
EN	End program
#C;BGS;EN	Begin Motion Subroutine

Vector Mode: Linear and Circular Interpolation Motion

The DMC-40x0 allows a long 2-D path consisting of linear and arc segments to be prescribed. Motion along the path is continuous at the prescribed vector speed even at transitions between linear and circular segments. The DMC-40x0 performs all the complex computations of linear and circular interpolation, freeing the host PC from this time intensive task.

The coordinated motion mode is similar to the linear interpolation mode. Any pair of two axes may be selected for coordinated motion consisting of linear and circular segments. In addition, a third axis can be controlled such that it remains tangent to the motion of the selected pair of axes. Note that only one pair of axes can be specified for coordinated motion at any given time.

The command VM m,n,p where 'm' and 'n' are the coordinated pair and p is the tangent axis (Note: the commas which separate m,n and p are not necessary). For example, VM XWZ selects the XW axes for coordinated motion and the Z-axis as the tangent.

Specifying the Coordinate Plane

The DMC-40x0 allows for 2 separate sets of coordinate axes for linear interpolation mode or vector mode. These two sets are identified by the letters S and T.

To specify vector commands the coordinate plane must first be identified. This is done by issuing the command CAS to identify the S plane or CAT to identify the T plane. All vector commands will be applied to the active coordinate system until changed with the CA command.

Specifying Vector Segments

The motion segments are described by two commands; VP for linear segments and CR for circular segments. Once a set of linear segments and/or circular segments have been specified, the sequence is ended with the command VE. This defines a sequence of commands for coordinated motion. Immediately prior to the execution of the first coordinated movement, the controller defines the current position to be zero for all movements in a sequence. Note:

This 'local' definition of zero does not affect the absolute coordinate system or subsequent coordinated motion sequences.

The command, VP x,y specifies the coordinates of the end points of the vector movement with respect to the starting point. Non-sequential axis do not require comma delimitation. The command, CR r,q,d define a circular arc with a radius r, starting angle of q, and a traversed angle d. The notation for q is that zero corresponds to the positive horizontal direction, and for both q and d, the counter-clockwise (CCW) rotation is positive.

Up to 511 segments of CR or VP may be specified in a single sequence and must be ended with the command VE. The motion can be initiated with a Begin Sequence (BGS) command. Once motion starts, additional segments may be added.

The Clear Sequence (CS) command can be used to remove previous VP and CR commands which were stored in the buffer prior to the start of the motion. To stop the motion, use the instructions STS or AB1. ST stops motion at the specified deceleration. AB1 aborts the motion instantaneously.

The Vector End (VE) command must be used to specify the end of the coordinated motion. This command requires the controller to decelerate to a stop following the last motion requirement. If a VE command is not given, an Abort (AB1) must be used to abort the coordinated motion sequence.

It is the responsibility of the user to keep enough motion segments in the DMC-40x0 sequence buffer to ensure continuous motion. If the controller receives no additional motion segments and no VE command, the controller will stop motion instantly at the last vector. There will be no controlled deceleration. LM? or _LM returns the available spaces for motion segments that can be sent to the buffer. 511 returned means the buffer is empty and 511 segments can be sent. A zero means the buffer is full and no additional segments can be sent. As long as the buffer is not full, additional segments can be sent at PC bus speeds.

The operand _CS can be used to determine the value of the segment counter.

Additional commands

The commands VS n, VA n and VD n are used for specifying the vector speed, acceleration, and deceleration.

IT is the s curve smoothing constant used with coordinated motion.

Specifying Vector Speed for Each Segment:

The vector speed may be specified by the immediate command VS. It can also be attached to a motion segment with the instructions

VP x,y < n > m

CR r,θ,δ < n > m

The first command, <n, is equivalent to commanding VS_n at the start of the given segment and will cause an acceleration toward the new commanded speeds, subjects to the other constraints.

The second function, > m, requires the vector speed to reach the value m at the end of the segment. Note that the function > m may start the deceleration within the given segment or during previous segments, as needed to meet the final speed requirement, under the given values of VA and VD.

Note, however, that the controller works with one > m command at a time. As a consequence, one function may be masked by another. For example, if the function >100000 is followed by >5000, and the distance for deceleration is not sufficient, the second condition will not be met. The controller will attempt to lower the speed to 5000, but will reach that at a different point.

Changing Feed Rate:

The command VR n allows the feed rate, VS, to be scaled between 0 and 10 with a resolution of .0001. This command takes effect immediately and causes VS scaled. VR also applies when the vector speed is specified with the '<' operator. This is a useful feature for feed rate override. VR does not ratio the accelerations. For example, VR 0.5 results in the specification VS 2000 to be divided by two.

Compensating for Differences in Encoder Resolution:

By default, the DMC-40x0 uses a scale factor of 1:1 for the encoder resolution when used in vector mode. If this is not the case, the command, ES can be used to scale the encoder counts. The ES command accepts two arguments which represent the number of counts for the two encoders used for vector motion. The smaller ratio of the two numbers will be multiplied by the higher resolution encoder. For more information, see ES command in the Command Reference.

Trippoints:

The AV n command is the After Vector trippoint, which waits for the vector relative distance of n to occur before executing the next command in a program.

Tangent Motion:

Several applications, such as cutting, require a third axis (i.e. a knife blade), to remain tangent to the coordinated motion path. To handle these applications, the DMC-40x0 allows one axis to be specified as the tangent axis. The VM command provides parameter specifications for describing the coordinated axes and the tangent axis.

VM m,n,p	m,n specifies coordinated axes p specifies tangent axis such as X,Y,Z,W p=N turns off tangent axis
----------	--

Before the tangent mode can operate, it is necessary to assign an axis via the VM command and define its offset and scale factor via the TN m,n command. m defines the scale factor in counts/degree and n defines the tangent position that equals zero degrees in the coordinated motion plane. The operand _TN can be used to return the initial position of the tangent axis.

Example:

Assume an XY table with the Z-axis controlling a knife. The Z-axis has a 2000 quad counts/rev encoder and has been initialized after power-up to point the knife in the +Y direction. A 180° circular cut is desired, with a radius of 3000, center at the origin and a starting point at (3000,0). The motion is CCW, ending at (-3000,0). Note that the 0° position in the XY plane is in the +X direction. This corresponds to the position -500 in the Z-axis, and defines the offset. The motion has two parts. First, X,Y and Z are driven to the starting point, and later, the cut is performed. Assume that the knife is engaged with output bit 0.

#EXAMPLE	Example program
VM XYZ	XY coordinate with Z as tangent
TN 2000/360,-500	2000/360 counts/degree, position -500 is 0 degrees in XY plane
CR 3000,0,180	3000 count radius, start at 0 and go to 180 CCW
VE	End vector
CB0	Disengage knife
PA 3000,0,_TN	Move X and Y to starting position, move Z to initial tangent position
BG XYZ	Start the move to get into position
AM XYZ	When the move is complete
SB0	Engage knife
WT50	Wait 50 msec for the knife to engage
BGS	Do the circular cut
AMS	After the coordinated move is complete
CB0	Disengage knife
MG "ALL DONE"	
EN	End program

Command Summary - Coordinated Motion Sequence

COMMAND	DESCRIPTION.
VM m,n	Specifies the axes for the planar motion where m and n represent the planar axes and p is the tangent axis.
VP m,n	Return coordinate of last point, where m=X,Y,Z or W.
CR r,Θ, ±ΔΘ	Specifies arc segment where r is the radius, Θ is the starting angle and ΔΘ is the travel angle. Positive direction is CCW.
VS s,t	Specify vector speed or feed rate of sequence.
VA s,t	Specify vector acceleration along the sequence.
VD s,t	Specify vector deceleration along the sequence.
VR s,t	Specify vector speed ratio
BGST	Begin motion sequence, S or T
CSST	Clear sequence, S or T
AV s,t	Trippoint for After Relative Vector distance.
AMST	Holds execution of next command until Motion Sequence is complete.
TN m,n	Tangent scale and offset.
ES m,n	Ellipse scale factor.
IT s,t	S curve smoothing constant for coordinated moves
LM?	Return number of available spaces for linear and circular segments in DMC-40x0 sequence buffer. Zero means buffer is full. 511 means buffer is empty.
CAS or CAT	Specifies which coordinate system is to be active (S or T)

Operand Summary - Coordinated Motion Sequence

OPERAND	DESCRIPTION
_VPM	The absolute coordinate of the axes at the last intersection along the sequence.
_AV	Distance traveled.
_LM	Number of available spaces for linear and circular segments in DMC-40x0 sequence buffer. Zero means buffer is full. 511 means buffer is empty.
_CS	Segment counter - Number of the segment in the sequence, starting at zero.
_VE	Vector length of coordinated move sequence.

When AV is used as an operand, _AV returns the distance traveled along the sequence.

The operands _VPX and _VPY can be used to return the coordinates of the last point specified along the path.

Example:

Traverse the path shown in Fig. 6.8. Feed rate is 20000 counts/sec. Plane of motion is XY

VM XY	Specify motion plane
VS 20000	Specify vector speed
VA 1000000	Specify vector acceleration
VD 1000000	Specify vector deceleration
VP -4000,0	Segment AB
CR 1500,270,-180	Segment BC

VP 0,3000	Segment CD
CR 1500,90,-180	Segment DA
VE	End of sequence
BGS	Begin Sequence

The resulting motion starts at the point A and moves toward points B, C, D, A. Suppose that we interrogate the controller when the motion is halfway between the points A and B.

The value of `_AV` is 2000

The value of `_CS` is 0

`_VPX` and `_VPY` contain the absolute coordinate of the point A

Suppose that the interrogation is repeated at a point, halfway between the points C and D.

The value of `_AV` is $4000+1500\pi+2000=10,712$

The value of `_CS` is 2

`_VPX`, `_VPY` contain the coordinates of the point C

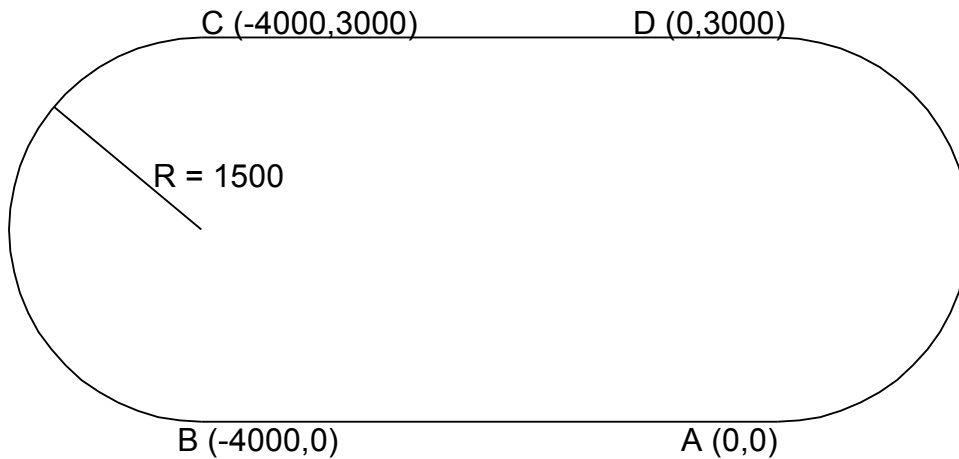

Figure 6.9: The Required Path

Electronic Gearing

This mode allows up to 8 axes to be electronically geared to some master axes. The masters may rotate in both directions and the geared axes will follow at the specified gear ratio. The gear ratio may be different for each axis and changed during motion.

The command `GAX yzw` or `GA ABCDEFGH` specifies the master axes. `GR x,y,z,w` specifies the gear ratios for the slaves where the ratio may be a number between ± 127.9999 with a fractional resolution of .0001. There are two modes: standard gearing and gantry mode. The gantry mode (enabled with the command `GM`) allows the gearing to stay enabled even if a limit is hit or an `ST` command is issued. `GR 0,0,0,0` turns off gearing in both modes.

The command `GM x,y,z,w` select the axes to be controlled under the gantry mode. The parameter 1 enables gantry mode, and 0 disables it.

`GR` causes the specified axes to be geared to the actual position of the master. The master axis is commanded with motion commands such as `PR`, `PA` or `JG`.

When the master axis is driven by the controller in the jog mode or an independent motion mode, it is possible to define the master as the command position of that axis, rather than the actual position. The designation of the commanded position master is by the letter, C. For example, `GACX` indicates that the gearing is the commanded position of X.

An alternative gearing method is to synchronize the slave motor to the commanded vector motion of several axes performed by GAS. For example, if the X and Y motor form a circular motion, the Z axis may move in proportion to the vector move. Similarly, if X,Y and Z perform a linear interpolation move, W can be geared to the vector move.

Electronic gearing allows the geared motor to perform a second independent or coordinated move in addition to the gearing. For example, when a geared motor follows a master at a ratio of 1:1, it may be advanced an additional distance with PR, or JG, commands, or VP, or LI.

Ramped Gearing

In some applications, especially when the master is traveling at high speeds, it is desirable to have the gear ratio ramp gradually to minimize large changes in velocity on the slave axis when the gearing is engaged. For example if the master axis is already traveling at 1,000,000 cts/sec and the slave will be geared at a ratio of 1:1 when the gearing is engaged, the slave will instantly develop following error, and command maximum current to the motor. This can be a large shock to the system. For many applications it is acceptable to slowly ramp the engagement of gearing over a greater time frame. Galil allows the user to specify an interval of the master axis over which the gearing will be engaged. For example, the same master X axis in this case travels at 1,000,000 counts/sec, and the gear ratio is 1:1, but the gearing is slowly engaged over 30,000 cts of the master axis, greatly diminishing the initial shock to the slave axis. Figure 6.10 below shows the velocity vs. time profile for instantaneous gearing. Figure 6.11 shows the velocity vs. time profile for the gradual gearing engagement.

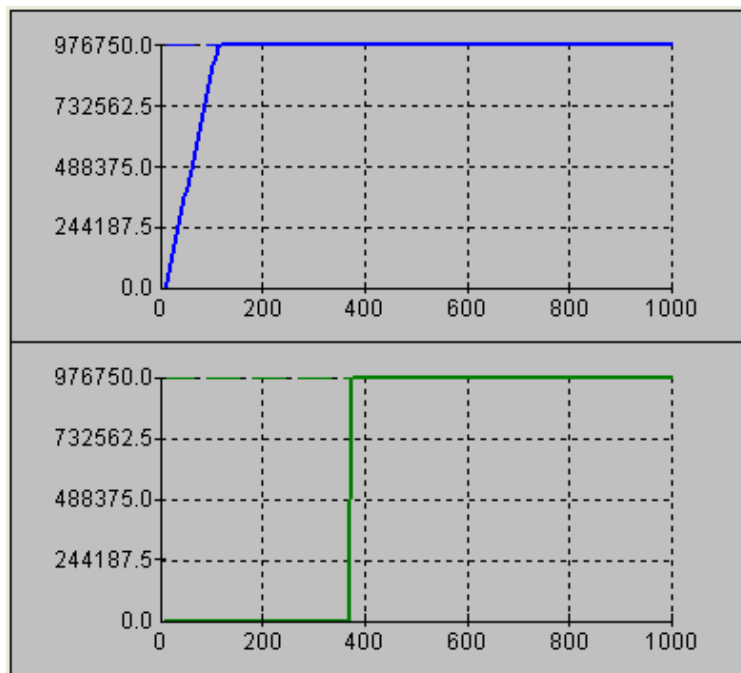

Figure 6.10: Velocity cts/sec vs. Time (msec) Instantaneous Gearing Engagement

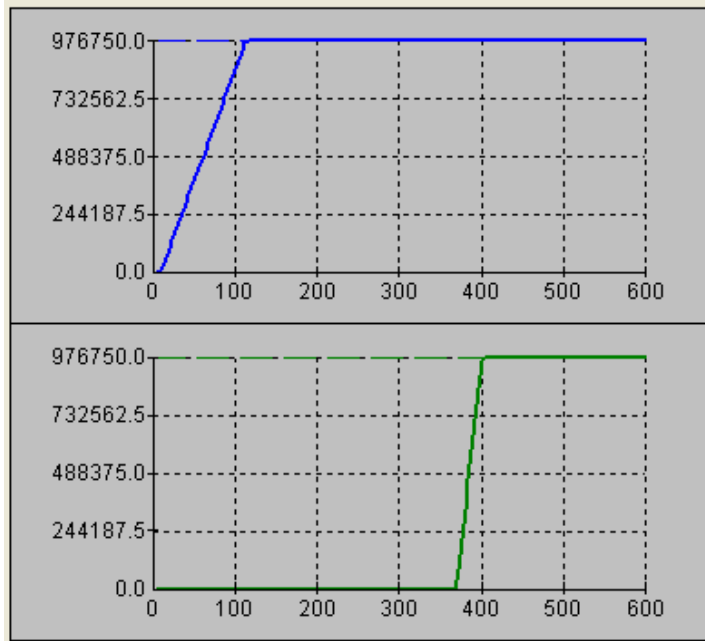

Figure 6.11: Velocity (cts/sec) vs. Time (msec) Ramped Gearing

The slave axis for each figure is shown on the bottom portion of the figure; the master axis is shown on the top portion. The shock to the slave axis will be significantly less in Figure 6.11 than in Figure 6.10. The ramped gearing does have one consequence. There isn't a true synchronization of the two axes, until the gearing ramp is complete. The slave will lag behind the true ratio during the ramp period. If exact position synchronization is required from the point gearing is initiated, then the position must be commanded in addition to the gearing. The controller keeps track of this position phase lag with the `_GP` operand. The following example will demonstrate how the command is used.

Example – Electronic Gearing Over a Specified Interval

Objective Run two geared motors at speeds of 1.132 and -.045 times the speed of an external master. Because the master is traveling at high speeds, it is desirable for the speeds to change slowly.

Solution: Use a DMC-4030 controller where the Z-axis is the master and X and Y are the geared axes. We will implement the gearing change over 6000 counts (3 revolutions) of the master axis.

```
MO Z           Turn Z off, for external master
GA Z, Z       Specify Z as the master axis for both X and Y.
GD6000,6000   Specify ramped gearing over 6000 counts of the master axis.
GR 1.132,-.045 Specify gear ratios
```

Question: What is the effect of the ramped gearing?

Answer: Below, in the example titled Electronic Gearing, gearing would take effect immediately. From the start of gearing if the master traveled 6000 counts, the slaves would travel 6792 counts and 270 counts.

Using the ramped gearing, the slave will engage gearing gradually. Since the gearing is engaged over the interval of 6000 counts of the master, the slave will only travel ~3396 counts and ~135 counts respectively. The difference between these two values is stored in the `_GPn` operand. If exact position synchronization is required, the `IP` command is used to adjust for the difference.

Command Summary - Electronic Gearing

COMMAND	DESCRIPTION
GA n	Specifies master axes for gearing where: n = X,Y,Z or W or A,B,C,D,E,F,G,H for main encoder as master n = CX,CY,CZ, CW or CA, CB,CC,CD,CE,CF,CG,CH for commanded position. n = DX,DY,DZ or DW or DA, DB, DC, DD, DE, DF,DG,DH for auxiliary encoders n = S or T for gearing to coordinated motion.
GD a,b,c,d,e,f,g,h	Sets the distance the master will travel for the gearing change to take full effect.
_GpN	This operand keeps track of the difference between the theoretical distance traveled if gearing changes took effect immediately, and the distance traveled since gearing changes take effect over a specified interval.
GR a,b,c,d,e,f,g,h	Sets gear ratio for slave axes. 0 disables electronic gearing for specified axis.
GM a,b,c,d,e,f,g,h	X = 1 sets gantry mode, 0 disables gantry mode
MR x,y,z,w	Trippoint for reverse motion past specified value. Only one field may be used.
MF x,y,z,w	Trippoint for forward motion past specified value. Only one field may be used.

Example - Simple Master Slave

Master axis moves 10000 counts at slew speed of 100000 counts/sec. Y is defined as the master. X,Z,W are geared to master at ratios of 5,-.5 and 10 respectively.

```
GA Y,,Y,Y          Specify master axes as Y
GR 5,,-.5,10      Set gear ratios
PR ,10000          Specify Y position
SP ,100000         Specify Y speed
BGY               Begin motion
```

Example - Electronic Gearing

Objective: Run two geared motors at speeds of 1.132 and -0.045 times the speed of an external master. The master is driven at speeds between 0 and 1800 RPM (2000 counts/rev encoder).

Solution: Use a DMC-4030 controller, where the Z-axis is the master and X and Y are the geared axes.

```
MO Z              Turn Z off, for external master
GA Z, Z           Specify Z as the master axis for both X and Y.
GR 1.132,-.045   Specify gear ratios
```

Now suppose the gear ratio of the X-axis is to change on-the-fly to 2. This can be achieved by commanding:

```
GR 2              Specify gear ratio for X axis to be 2
```

Example - Gantry Mode

In applications where both the master and the follower are controlled by the DMC-40x0 controller, it may be desired to synchronize the follower with the commanded position of the master, rather than the actual position. This eliminates the coupling between the axes which may lead to oscillations.

For example, assume that a gantry is driven by two axes, X,Y, on both sides. This requires the gantry mode for strong coupling between the motors. The X-axis is the master and the Y-axis is the follower. To synchronize Y with the commanded position of X, use the instructions:

```
GA, CX           Specify the commanded position of X as master for Y.
```

GR,1	Set gear ratio for Y as 1:1
GM,1	Set gantry mode
PR 3000	Command X motion
BG X	Start motion on X axis

You may also perform profiled position corrections in the electronic gearing mode. Suppose, for example, that you need to advance the slave 10 counts. Simply command

IP ,10	Specify an incremental position movement of 10 on Y axis.
--------	---

Under these conditions, this IP command is equivalent to:

PR,10	Specify position relative movement of 10 on Y axis
BGY	Begin motion on Y axis

Often the correction is quite large. Such requirements are common when synchronizing cutting knives or conveyor belts.

Example - Synchronize two conveyor belts with trapezoidal velocity correction

GA,X	Define X as the master axis for Y.
GR,2	Set gear ratio 2:1 for Y
PR,300	Specify correction distance
SP,5000	Specify correction speed
AC,100000	Specify correction acceleration
DC,100000	Specify correction deceleration
BGY	Start correction

Electronic Cam

The electronic cam is a motion control mode which enables the periodic synchronization of several axes of motion. Up to 7 axes can be slaved to one master axis. The master axis encoder must be input through a main encoder port.

The electronic cam is a more general type of electronic gearing which allows a table-based relationship between the axes. It allows synchronizing all the controller axes. For example, the DMC-4080 controllers may have one master and up to seven slaves.

To illustrate the procedure of setting the cam mode, consider the cam relationship for the slave axis Y, when the master is X. Such a graphic relationship is shown in Figure 6.12.

Step 1. Selecting the master axis

The first step in the electronic cam mode is to select the master axis. This is done with the instruction

EAp where p = X,Y,Z,W,E,F,G,H

p is the selected master axis

For the given example, since the master is x, we specify EAX

Step 2. Specify the master cycle and the change in the slave axis (or axes).

In the electronic cam mode, the position of the master is always expressed modulo one cycle. In this example, the position of x is always expressed in the range between 0 and 6000. Similarly, the slave position is also redefined such that it starts at zero and ends at 1500. At the end of a cycle when the master is 6000 and the slave is 1500, the positions of both x and y are redefined as zero. To specify the master cycle and the slave cycle change, we use the instruction EM.

EM x, y, z, w

where x,y,z,w specify the cycle of the master and the total change of the slaves over one cycle.

The cycle of the master is limited to 8,388,607 whereas the slave change per cycle is limited to 2,147,483,647. If the change is a negative number, the absolute value is specified. For the given example, the cycle of the master is 6000 counts and the change in the slave is 1500. Therefore, we use the instruction:

```
EM 6000,1500
```

Step 3. Specify the master interval and starting point.

Next we need to construct the ECAM table. The table is specified at uniform intervals of master positions. Up to 256 intervals are allowed. The size of the master interval and the starting point are specified by the instruction:

```
EP m, n
```

where m is the interval width in counts, and n is the starting point.

For the given example, we can specify the table by specifying the position at the master points of 0, 2000, 4000 and 6000. We can specify that by

```
EP 2000, 0
```

Step 4. Specify the slave positions.

Next, we specify the slave positions with the instruction

```
ET [n]=x, y, z, w
```

where n indicates the order of the point.

The value, n, starts at zero and may go up to 256. The parameters x,y,z,w indicate the corresponding slave position. For this example, the table may be specified by

```
ET [0]=, 0  
ET [1]=, 3000  
ET [2]=, 2250  
ET [3]=, 1500
```

This specifies the ECAM table.

Step 5. Enable the ECAM

To enable the ECAM mode, use the command

```
EB n
```

where n=1 enables ECAM mode and n=0 disables ECAM mode.

Step 6. Engage the slave motion

To engage the slave motion, use the instruction

```
EG x, y, z, w
```

where x,y,z,w are the master positions at which the corresponding slaves must be engaged.

If the value of any parameter is outside the range of one cycle, the cam engages immediately. When the cam is engaged, the slave position is redefined, modulo one cycle.

Step 7. Disengage the slave motion

To disengage the cam, use the command

```
EQ x, y, z, w
```

where x,y,z,w are the master positions at which the corresponding slave axes are disengaged.

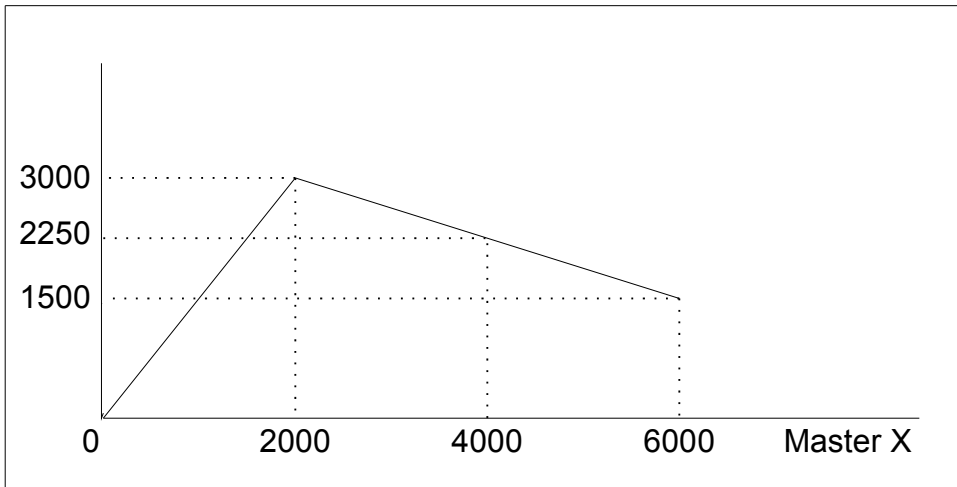

Figure 6.12: Electronic Cam Example

This disengages the slave axis at a specified master position. If the parameter is outside the master cycle, the stopping is instantaneous.

To illustrate the complete process, consider the cam relationship described by the equation:

$$Y = 0.5 * X + 100 \sin (0.18 * X)$$

where X is the master, with a cycle of 2000 counts.

The cam table can be constructed manually, point by point, or automatically by a program. The following program includes the set-up.

The instruction EAX defines X as the master axis. The cycle of the master is 2000. Over that cycle, Y varies by 1000. This leads to the instruction EM 2000,1000.

Suppose we want to define a table with 100 segments. This implies increments of 20 counts each. If the master points are to start at zero, the required instruction is EP 20,0.

The following routine computes the table points. As the phase equals $0.18X$ and X varies in increments of 20, the phase varies by increments of 3.6° . The program then computes the values of Y according to the equation and assigns the values to the table with the instruction ET[N] = ,Y.

INSTRUCTION	INTERPRETATION
#SETUP	Label
EAX	Select X as master
EM 2000,1000	Cam cycles
EP 20,0	Master position increments
N = 0	Index
#LOOP	Loop to construct table from equation
P = N*3.6	Note 3.6 = 0.18 * 20
S = @SIN [P]*100	Define sine position
Y = N*10+S	Define slave position
ET [N] =, Y	Define table
N = N+1	
JP #LOOP, N<=100	Repeat the process
EN	

Now suppose that the slave axis is engaged with a start signal, input 1, but that both the engagement and disengagement points must be done at the center of the cycle: $X = 1000$ and $Y = 500$. This implies that Y must be driven to that point to avoid a jump.

This is done with the program:

INSTRUCTION	INTERPRETATION
#RUN	Label
EB1	Enable cam
PA,500	starting position
SP,5000	Y speed
BGY	Move Y motor
AM	After Y moved
AI1	Wait for start signal
EG,1000	Engage slave
AI - 1	Wait for stop signal
EQ,1000	Disengage slave
EN	End

Command Summary - Electronic CAM

Command	Description
EA p	Specifies master axes for electronic cam where: p = X,Y,Z or W or A,B,C,D,E,F,G,H for main encoder as master or M or N a for virtual axis master
EB n	Enables the ECAM
EC n	ECAM counter - sets the index into the ECAM table
EG x,y,z,w	Engages ECAM
EM x,y,z,w	Specifies the change in position for each axis of the CAM cycle
EP m,n	Defines CAM table entry size and offset
EQ m,n	Disengages ECAM at specified position
ET[n]	Defines the ECAM table entries
EW	Widen Segment (see Application Note #2444)
EY	Set ECAM cycle count

Operand Summary - Electronic CAM

Command	Description
_EB	Contains State of ECAM
_EC	Contains current ECAM index
_EGx	Contains ECAM status for each axis
_EM	Contains size of cycle for each axis
_EP	Contains value of the ECAM table interval
_EQx	Contains ECAM status for each axis
_EY	Set ECAM cycle count

Example - Electronic CAM

The following example illustrates a cam program with a master axis, Z, and two slaves, X and Y.

INSTRUCTION	INTERPRETATION
#A;V1=0	Label; Initialize variable
PA 0,0;BGXY;AMXY	Go to position 0,0 on X and Y axes
EA Z	Z axis as the Master for ECAM
EM 0,0,4000	Change for Z is 4000, zero for X, Y
EP400,0	ECAM interval is 400 counts with zero start
ET[0]=0,0	When master is at 0 position; 1 st point.
ET[1]=40,20	2 nd point in the ECAM table
ET[2]=120,60	3 rd point in the ECAM table
ET[3]=240,120	4 th point in the ECAM table
ET[4]=280,140	5 th point in the ECAM table
ET[5]=280,140	6 th point in the ECAM table
ET[6]=280,140	7 th point in the ECAM table
ET[7]=240,120	8 th point in the ECAM table
ET[8]=120,60	9 th point in the ECAM table

ET[9]=40,20	10 th point in the ECAM table
ET[10]=0,0	Starting point for next cycle
EB 1	Enable ECAM mode
JGZ=4000	Set Z to jog at 4000
EG 0,0	Engage both X and Y when Master = 0
BGZ	Begin jog on Z axis
#LOOP;JP#LOOP,V1=0	Loop until the variable is set
EQ2000,2000	Disengage X and Y when Master = 2000
MF,, 2000	Wait until the Master goes to 2000
ST Z	Stop the Z axis motion
EB 0	Exit the ECAM mode
EN	End of the program

The above example shows how the ECAM program is structured and how the commands can be given to the controller. The next page provides the results captured by the WSDK program. This shows how the motion will be seen during the ECAM cycles. The first graph is for the X axis, the second graph shows the cycle on the Y axis and the third graph shows the cycle of the Z axis.

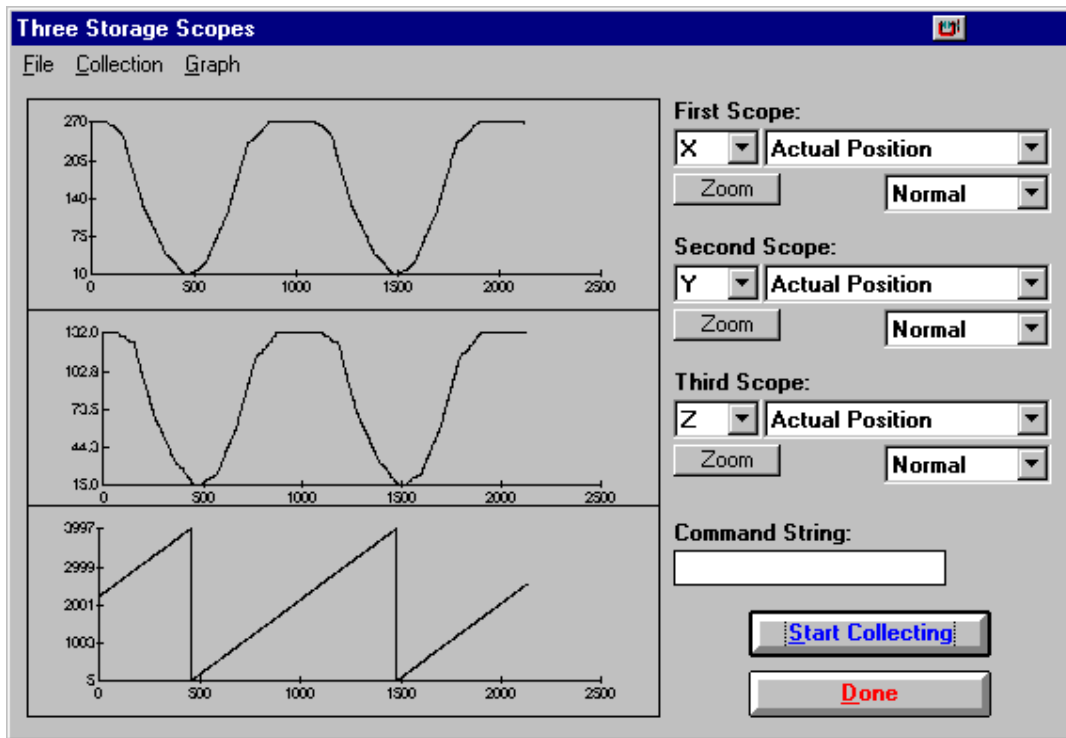

Figure 6.13: Three Storage Scopes

PVT Mode

The DMC-40x0 controllers now supports a mode of motion referred to as “PVT.” This mode allows arbitrary motion profiles to be defined by position, velocity and time individually on all 8 axes. This motion is designed for systems where the load must traverse a series of coordinates with no discontinuities in velocity. By specifying the target position, velocity and time to achieve those parameters the user has control over the velocity profile. Taking advantage of the built in buffering the user can create virtually any profile including those with infinite path lengths.

Specifying PVT Segments

PVT segments must be entered one axis at a time using the PVn command. The PV command includes the target distance to be moved and target velocity to be obtained over the specified timeframe. Positions are entered as relative moves, similar to the standard PR command, in units of encoder counts and velocity is entered in counts/second. The controller will interpolate the motion profile between subsequent PV commands using a 3rd order polynomial equation. During a PV segment, jerk is held constant, and accelerations, velocities, and positions will be calculated every other sample.

Motion will not begin until a BT command is issued, much like the standard BG command. This means that the user can fill the PVT buffer for each axis prior to motion beginning. The BT command will ensure that all axes begin motion simultaneously. It is not required for the “t” value for each axis to be the same, however if they are then the axes will remain coordinated. Each axis has a 255 segment buffer. This buffer is a FIFO and the available space can be queried with the operand _PVn. As the buffer empties the user can add more PVT segments.

Exiting PVT Mode

To exit PVT mode the user must send the segment command PVn=0,0,0. This will exit the mode once the segment is reached in the buffer. To avoid an abrupt stop the user should slow the motion to a zero velocity prior to executing this command. The controller will instantly command a zero velocity once a PVn=0,0,0 is executed. In addition, a ST command will also exit PVT mode. Motion will come to a controlled stop using the DC value for deceleration. The same controlled stop will occur if a limit switch is activated in the direction of motion. As a result, the controller will be switched to a jog mode of motion.

Error Conditions and Stop Codes

If the buffer is allowed to empty while in PVT mode then the profiling will be aborted and the motor will come to a controlled stop on that axis with a deceleration specified by the DC command. Also, PVT mode will be exited and the stop code will be set to 32. During normal operation of PVT mode the stop code will be 30. If PVT mode is exited normally (PVn=0,0,0), then the stop code will be set to 31.

Additional PVT Information

It is the users’ responsibility to enter PVT data that the system’s mechanics and power system can respond to in a reasonable manner. Because this mode of motion is not constrained by the AC, DC or SP values, if a large velocity or position is entered with a short period to achieve it, the acceleration can be very high, beyond the capabilities of the system, resulting in excessive position error. The position and velocity at the end of the segment are guaranteed to be accurate but it is important to remember that the required path to obtain the position and velocity in the specified time may be different based on the PVT values. Mismatched values for PVT can result in different interpolated profiles than expected but the final velocity and position will be accurate.

The “t” value is entered in samples, which will depend on the TM setting. With the default TM of 1000, one sample is 976us. This means that a “t” value of 1024 will yield one second of motion. The velocity value, “v” will always be in units of counts per second, regardless of the TM setting. PVT mode is not available in the “-FAST” version of the firmware. If this is required please consult Galil.

Command Summary – PVT

COMMAND	DESCRIPTION
PVa = p,v,t	Specifies the segment of axis 'a' for a incremental PVT segment of 'p' counts, an end speed of 'v' counts/sec in a total time of 't' samples.
_PVa	Contains the number of PV segments available in the PV buffer for a specified axes.
BT	Begin PVT mode
_BTa	Contains the number PV segments that have executed

PVT Examples

Parabolic Velocity Profile

In this example we will assume that the user wants to start from zero velocity, accelerate to a maximum velocity of 1000 counts/second in 1 second and then back down to 0 counts/second within an additional second. The velocity profile would be described by the following equation and shown in Figure 6.14.

$$v(t) = -1000(t - 1)^2 + 1000$$

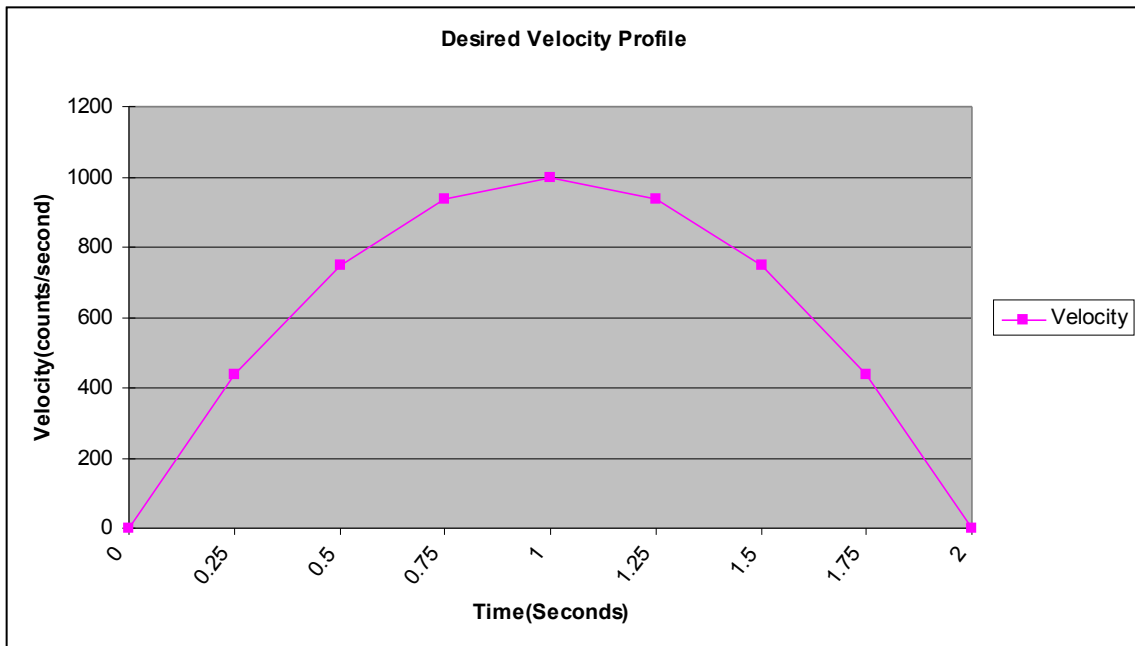

Figure 6.14: Parabolic Velocity Profile

To accomplish this we need to calculate the desired velocities and change in positions. In this example we will assume a delta time of ¼ of a second, which is 256 samples (1024 samples = 1 second with the default TM of 1000).

Velocity(counts/second)	Position(counts)
$v(t) = -1000(t - 1)^2 + 1000$	$p(t) = \int (-1000(t - 1)^2 + 1000)dt$

$v(.25) = 437.5$	$p(0 \text{ to } .25) = 57$
$v(.5) = 750$	$p(.25 \text{ to } .5) = 151$
$v(.75) = 937.5$	$p(.5 \text{ to } .75) = 214$
$v(1) = 1000$	$p(.75 \text{ to } 1) = 245$
$v(1.25) = 937.5$	$p(1 \text{ to } 1.25) = 245$
$v(1.5) = 750$	$p(1.25 \text{ to } 1.5) = 214$
$v(1.75) = 437.5$	$p(1.5 \text{ to } 1.75) = 151$
$v(2) = 0$	$p(1.75 \text{ to } 2) = 57$

The DMC program is shown below and the results can be seen in Figure 6.15.

INSTRUCTION

INTERPRETATION

#PVT	Label
PVX = 57,437,256	Incremental move of 57 counts in 256 samples with a final velocity of 437 counts/sec
PVX = 151,750,256	Incremental move of 151 counts in 256 samples with a final velocity of 750 counts/sec
PVX = 214,937,256	Incremental move of 214 counts in 256 samples with a final velocity of 937 counts/sec
PVX = 245,1000,256	Incremental move of 245 counts in 256 samples with a final velocity of 1000 counts/sec
PVX = 245,937,256	Incremental move of 245 counts in 256 samples with a final velocity of 937 counts/sec
PVX = 214,750,256	Incremental move of 214 counts in 256 samples with a final velocity of 750 counts/sec
PVX = 151,437,256	Incremental move of 151 counts in 256 samples with a final velocity of 437 counts/sec
PVX = 57,0,256	Incremental move of 57 counts in 256 samples with a final velocity of 0 counts/sec
PVX = 0,0,0	Termination of PVT buffer
BTX	Begin PVT
EN	

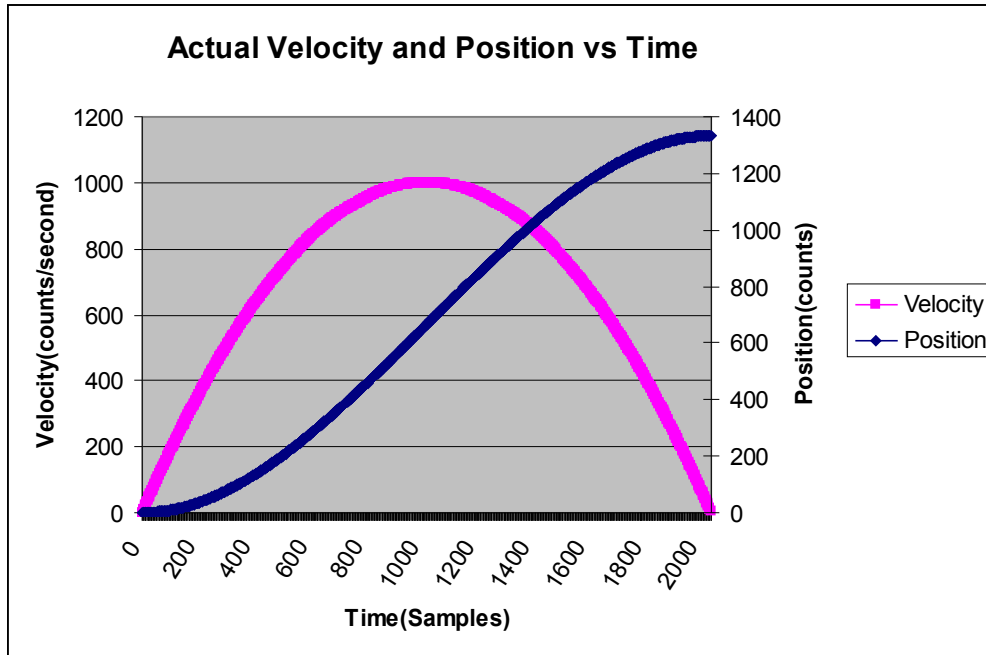

Figure 6.15: Actual Velocity and Position vs Time of Parabolic Velocity Profile

Multi-Axis Coordinated Move

Many applications require moving two or more axes in a coordinated move yet still require smooth motion at the same time. These applications are ideal candidates for PVT mode.

In this example we will have a 2 dimensional stage that needs to follow a specific profile. The application requires that the certain points be met however the path between points is not important. Smooth motion between points is critical.

X Axis	Y Axis
500	500
1500	5000
2500	4000
3300	4200
7300	3300

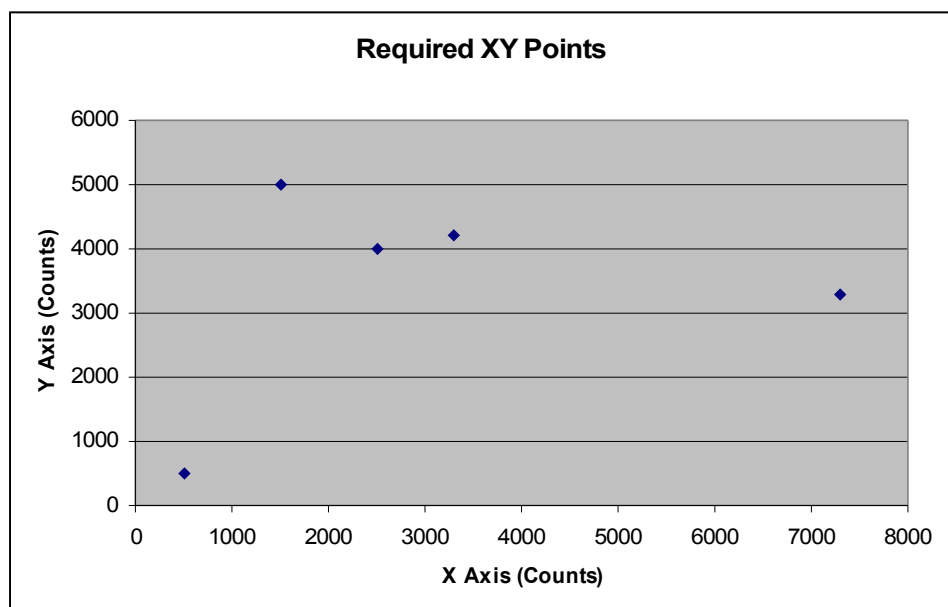

Figure 6.16: Required XY Points

The resultant DMC program is shown below. The position points are dictated by the application requirements and the velocities and times were chosen to create smooth yet quick motion. For example, in the second segment the B axis is slowed to 0 at the end of the move in anticipation of reversing direction during the next segment.

INSTRUCTION	INTERPRETATION
#PVT	Label
PVA = 500,2000,500	1 st point in Figure 6.16 - A axis
PVB = 500,5000,500	1 st point in Figure 6.16 - B axis
PVA = 1000,4000,1200	2 nd point in Figure 6.16 - A axis
PVB = 4500,0,1200	2 nd point in Figure 6.16 - B axis
PVA = 1000,4000,750	3 rd point in Figure 6.16 - A axis
PVB = -1000,1000,750	3 rd point in Figure 6.16 - B axis
BTAB	Begin PVT mode for A and B axes
PVA = 800,10000,250	4 th point in Figure 6.16 - A axis
PVB = 200,1000,250	4 th point in Figure 6.16 - B axis
PVA = 4000,0,1000	5 th point in Figure 6.16 - A axis
PVB = -900,0,1000	5 th point in Figure 6.16 - B axis
PVA = 0,0,0	Termination of PVT buffer for A axis
PVB = 0,0,0	Termination of PVT buffer for B axis
EN	

NOTE: The BT command is issued prior to filling the PVT buffers and additional PV commands are added during motion for demonstration purposes only. The BT command could have been issued at the end of all the PVT points in this example.

The resultant X vs. Y position graph is shown in Figure 6.17, with the specified PVT points enlarged.

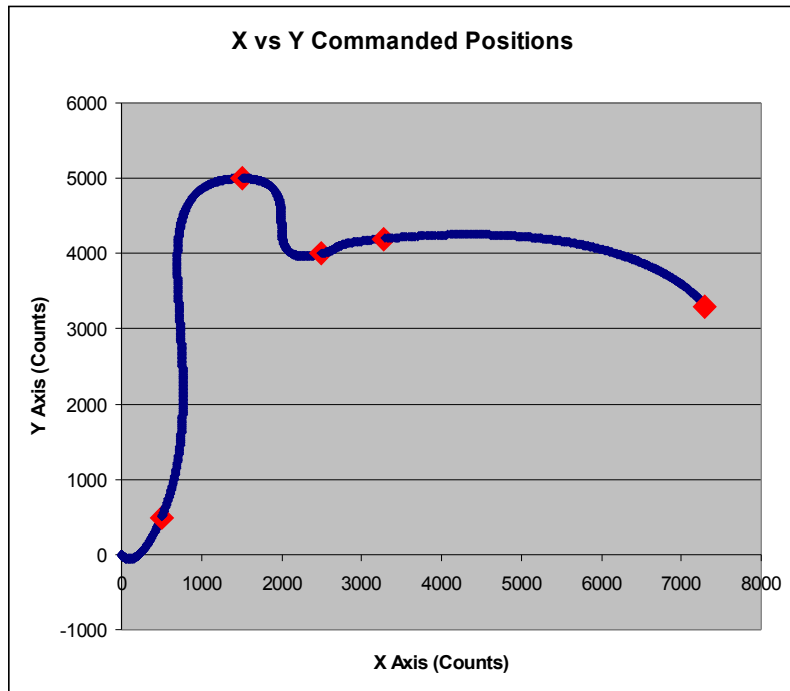

Figure 6.17: X vs Y Commanded Positions for Multi-Axis Coordinated Move

Contour Mode

The DMC-40x0 also provides a contouring mode. This mode allows any arbitrary position curve to be prescribed for 1 to 8 axes. This is ideal for following computer generated paths such as parabolic, spherical or user-defined profiles. The path is not limited to straight line and arc segments and the path length may be infinite.

Specifying Contour Segments

The Contour Mode is specified with the command, CM. For example, CMXZ specifies contouring on the X and Z axes. Any axes that are not being used in the contouring mode may be operated in other modes.

A contour is described by position increments which are described with the command, CD x,y,z,w over a time interval, DT n. The parameter, n, specifies the time interval. The time interval is defined as 2n sample period (1 ms for TM1000), where n is a number between 1 and 8. The controller performs linear interpolation between the specified increments, where one point is generated for each sample. If the time interval changes for each segment, use CD x,y,z,w=n where n is the new DT value.

Consider, for example, the trajectory shown in Fig. 6.18. The position X may be described by the points:

Point 1	X=0 at T=0ms
Point 2	X=48 at T=4ms
Point 3	X=288 at T=12ms
Point 4	X=336 at T=28ms

The same trajectory may be represented by the increments

Increment 1	DX=48	Time=4	DT=2
Increment 2	DX=240	Time=8	DT=3
Increment 3	DX=48	Time=16	DT=4

When the controller receives the command to generate a trajectory along these points, it interpolates linearly between the points. The resulting interpolated points include the position 12 at 1 msec, position 24 at 2 msec, etc.

The programmed commands to specify the above example are:

```
#A
CMX           Specifies X axis for contour mode
CD 48=2       Specifies first position increment and time interval, 22 ms
CD 240=3      Specifies second position increment and time interval, 23 ms
CD 48=4       Specifies the third position increment and time interval, 24 ms
CD 0=0        End Contour buffer
#Wait;JP#Wait,_CM<>511  Wait until path is done
EN
```

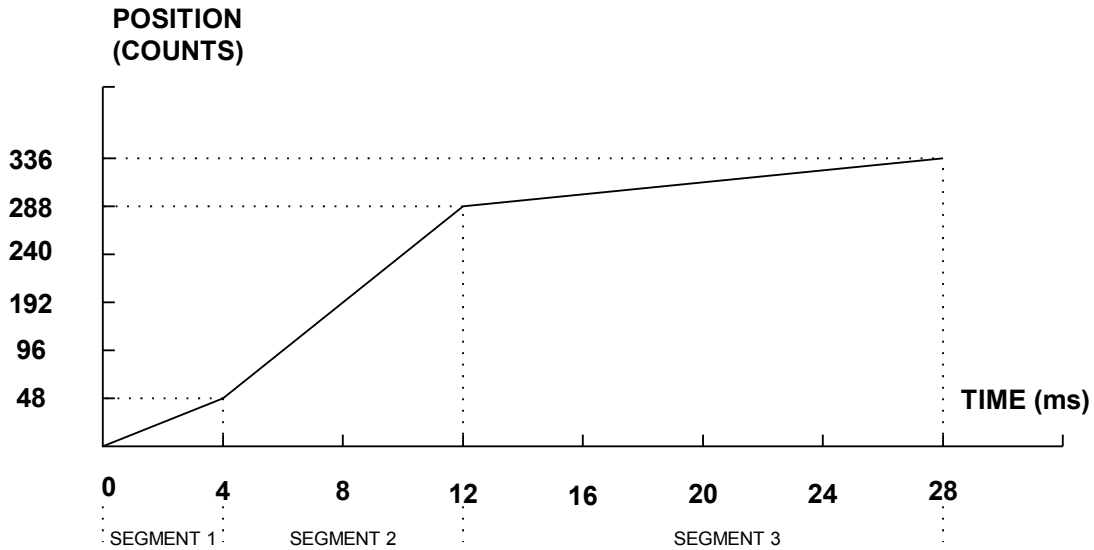

Figure 6.18: The Required Trajectory

Additional Commands

CM gives the amount of space available in the contour buffer (511 maximum). Zero parameters for DT followed by zero parameters for CD exit the contour mode.

If no new data record is found and the controller is still in the contour mode, the controller waits for new data. No new motion commands are generated while waiting. If bad data is received, the controller responds with a ?.

Command Summary - Contour Mode

COMMAND	DESCRIPTION
CM XYZW	Specifies which axes for contouring mode. Any non-contouring axes may be operated in other modes.
CM ABCDEFGH	Contour axes for DMC-4080
CD x,y,z,w	Specifies position increment over time interval. Range is +/-32,000. CD 0,0,0.. =0 ends the contour buffer. This is much like the LE or VE commands.
CD a,b,c,d,e,f,g,h	Position increment data for DMC-4080
DT n	Specifies time interval 2 ⁿ sample periods (1 ms for TM1000) for position increment, where n is an integer between 1 and 8. Zero ends contour mode. If n does not change, it does not need to be specified with each CD.
<u>CM</u>	Amount of space left in contour buffer (511 maximum)

General Velocity Profiles

The Contour Mode is ideal for generating any arbitrary velocity profiles. The velocity profile can be specified as a mathematical function or as a collection of points.

The design includes two parts: Generating an array with data points and running the program.

Generating an Array - An Example

Consider the velocity and position profiles shown in Fig. 6.14. The objective is to rotate a motor a distance of 6000 counts in 120 ms. The velocity profile is sinusoidal to reduce the jerk and the system vibration. If we describe the position displacement in terms of A counts in B milliseconds, we can describe the motion in the following manner:

$$\omega = \frac{A}{B} (1 - \cos(2\pi/B))$$

$$X = \frac{AT}{B} - \frac{A}{2\pi} \sin(2\pi/B)$$

Note: ω is the angular velocity; X is the position; and T is the variable, time, in milliseconds.

In the given example, A=6000 and B=120, the position and velocity profiles are:

$$X = 50T - (6000/2\pi) \sin(2\pi T/120)$$

Note that the velocity, ω , in count/ms, is

$$\omega = 50 [1 - \cos 2\pi T/120]$$

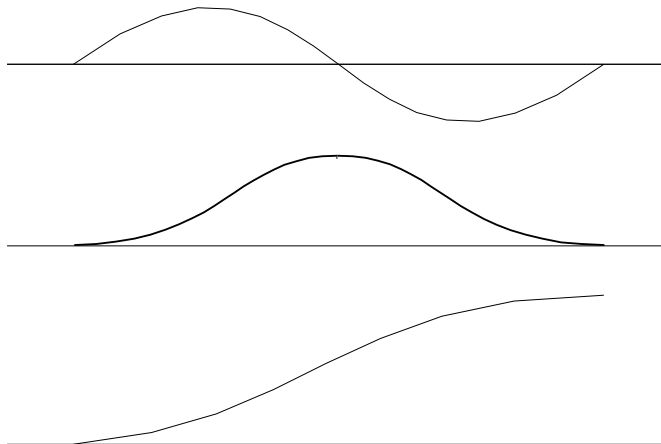

Figure 6.19: Velocity Profile with Sinusoidal Acceleration

The DMC-40x0 can compute trigonometric functions. However, the argument must be expressed in degrees. Using our example, the equation for X is written as:

$$X = 50T - 955 \sin 3T$$

A complete program to generate the contour movement in this example is given below. To generate an array, we compute the position value at intervals of 8 ms. This is stored at the array POS. Then, the difference between the positions is computed and is stored in the array DIF. Finally the motors are run in the contour mode.

Contour Mode Example

INSTRUCTION	INTERPRETATION
#POINTS	Program defines X points
DM POS[16]	Allocate memory
DM DIF[15]	
C=0	Set initial conditions, C is index
T=0	T is time in ms
#A	
V1=50*T	
V2=3*T	Argument in degrees
V3=-955*@SIN[V2]+V1	Compute position
V4=@INT[V3]	Integer value of V3
POS[C]=V4	Store in array POS
T=T+8	
C=C+1	
JP #A,C<16	

```

#B                Program to find position differences
C=0
#C
D=C+1
DIF[C]=POS[D]-POS[C]  Compute the difference and store
C=C+1
JP #C,C<15

#RUN             Program to run motor
CMX             Contour Mode
DT3            8 millisecond intervals
C=0
#E
CD DIF[C]      Contour Distance is in DIF
C=C+1
JP #E,C<15
CD 0=0        End contour buffer
#Wait;JP#Wait,_CM<>511  Wait until path is done
EN            End the program

```

Teach (Record and Play-Back)

Several applications require teaching the machine a motion trajectory. Teaching can be accomplished using the DMC-40x0 automatic array capture feature to capture position data. The captured data may then be played back in the contour mode. The following array commands are used:

```

DM C[n]         Dimension array
RA C[]         Specify array for automatic record (up to 4 for DMC-4040)
RD _TPX        Specify data for capturing (such as _TPX or _TPZ)
RC n,m         Specify capture time interval where n is 2n sample periods (1
              ms for TM1000), m is number of records to be captured
RC? or _RC     Returns a 1 if recording

```

Record and Playback Example:

```

#RECORD        Begin Program
DM XPOS[501]   Dimension array with 501 elements
RA XPOS[]     Specify automatic record
RD _TPX       Specify X position to be captured
MOX           Turn X motor off
RC2           Begin recording; 4 msec interval (at TM1000)
#A;JP#A,_RC=1 Continue until done recording
#COMPUTE      Compute DX
DM DX[500]    Dimension Array for DX
C=0           Initialize counter
#L            Label
D=C+1
DELTA=XPOS[D]-XPOS[C]  Compute the difference
DX[C]=DELTA   Store difference in array
C=C+1         Increment index
JP #L,C<500   Repeat until done

```

```

#PLAYBCK          Begin Playback
CMX              Specify contour mode
DT2             Specify time increment
I=0             Initialize array counter
#B              Loop counter
CD DX[I]; I=I+1  Specify contour data I=I+1 Increment array counter
JP #B,I<500      Loop until done
CD 0=0          End countour buffer
#Wait;JP#Wait,_CM<>511 Wait until path is done
EN              End program

```

For additional information about automatic array capture, see [Chapter 7, Arrays](#).

Virtual Axis

The DMC-40x0 controller has two additional virtual axes designated as the M and N axes. These axes have no encoder and no DAC. However, they can be commanded by the commands:

```
AC, DC, JG, SP, PR, PA, BG, IT, GA, VM, VP, CR, ST, DP, RP
```

The main use of the virtual axes is to serve as a virtual master in ECAM modes, and to perform an unnecessary part of a vector mode. These applications are illustrated by the following examples.

ECAM Master Example

Suppose that the motion of the XY axes is constrained along a path that can be described by an electronic cam table. Further assume that the ecam master is not an external encoder but has to be a controlled variable.

This can be achieved by defining the N axis as the master with the command EAN and setting the modulo of the master with a command such as EMN= 4000. Next, the table is constructed. To move the constrained axes, simply command the N axis in the jog mode or with the PR and PA commands.

For example,

```
PAN = 2000
BGN
```

will cause the XY axes to move to the corresponding points on the motion cycle.

Sinusoidal Motion Example

The x axis must perform a sinusoidal motion of 10 cycles with an amplitude of 1000 counts and a frequency of 20 Hz.

This can be performed by commanding the X and N axes to perform circular motion. Note that the value of VS must be

$$VS=2\pi * R * F$$

where R is the radius, or amplitude and F is the frequency in Hz.

Set VA and VD to maximum values for the fastest acceleration.

INSTRUCTION	INTERPRETATION
VMXN	Select Axes
VA 68000000	Maximum Acceleration
VD 68000000	Maximum Deceleration
VS 125664	VS for 20 Hz
CR 1000, -90, 3600	Ten Cycles
VE	
BGS	

Stepper Motor Operation

When configured for stepper motor operation, several commands are interpreted differently than from servo mode. The following describes operation with stepper motors.

Specifying Stepper Motor Operation

Stepper motor operation is specified by the command MT. The argument for MT is as follows:

- 2 specifies a stepper motor with active low step output pulses
- 2 specifies a stepper motor with active high step output pulses
- 2.5 specifies a stepper motor with active low step output pulses and reversed direction
- 2.5 specifies a stepper motor with active high step output pulse and reversed direction

Stepper Motor Smoothing

The command, KS, provides stepper motor smoothing. The effect of the smoothing can be thought of as a simple Resistor-Capacitor (single pole) filter. The filter occurs after the motion profiler and has the effect of smoothing out the spacing of pulses for a more smooth operation of the stepper motor. Use of KS is most applicable when operating in full step or half step operation. KS will cause the step pulses to be delayed in accordance with the time constant specified.

When operating with stepper motors, you will always have some amount of stepper motor smoothing, KS. Since this filtering effect occurs after the profiler, the profiler may be ready for additional moves before all of the step pulses have gone through the filter. It is important to consider this effect since steps may be lost if the controller is commanded to generate an additional move before the previous move has been completed. See the discussion below, Monitoring Generated Pulses vs. Commanded Pulses.

The general motion smoothing command, IT, can also be used. The purpose of the command, IT, is to smooth out the motion profile and decrease 'jerk' due to acceleration.

Monitoring Generated Pulses vs. Commanded Pulses

For proper controller operation, it is necessary to make sure that the controller has completed generating all step pulses before making additional moves. This is most particularly important if you are moving back and forth. For example, when operating with servo motors, the trippoint AM (After Motion) is used to determine when the motion profiler is complete and is prepared to execute a new motion command. However when operating in stepper mode, the controller may still be generating step pulses when the motion profiler is complete. This is caused by the stepper motor smoothing filter, KS. To understand this, consider the steps the controller executes to generate step pulses:

First, the controller generates a motion profile in accordance with the motion commands.

Second, the profiler generates pulses as prescribed by the motion profile. The pulses that are generated by the motion profiler can be monitored by the command, RP (Reference Position). RP gives the absolute value of the position as determined by the motion profiler. The command, DP, can be used to set the value of the reference position. For example, DP 0, defines the reference position of the X axis to be zero.

Third, the output of the motion profiler is filtered by the stepper smoothing filter. This filter adds a delay in the output of the stepper motor pulses. The amount of delay depends on the parameter which is specified by the command, KS. As mentioned earlier, there will always be some amount of stepper motor smoothing. The default value for KS is 1.313 which corresponds to a time constant of 3.939 sample periods.

Fourth, the output of the stepper smoothing filter is buffered and is available for input to the stepper motor driver. The pulses which are generated by the smoothing filter can be monitored by the command, TD (Tell Dual). TD gives the absolute value of the position as determined by actual output of the buffer. The command, DP sets the value of the step count register as well as the value of the reference position. For example, DP 0, defines the reference position of the X axis to be zero.

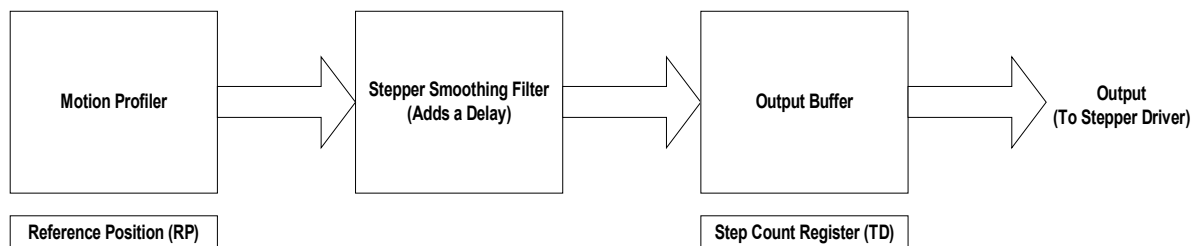

Motion Complete Trippoint

When used in stepper mode, the MC command will hold up execution of the proceeding commands until the controller has generated the same number of steps out of the step count register as specified in the commanded position. The MC trippoint (Motion Complete) is generally more useful than AM trippoint (After Motion) since the step pulses can be delayed from the commanded position due to stepper motor smoothing.

Using an Encoder with Stepper Motors

An encoder may be used on a stepper motor to check the actual motor position with the commanded position. If an encoder is used, it must be connected to the main encoder input. Note: The auxiliary encoder is not available while operating with stepper motors. The position of the encoder can be interrogated by using the command, TP. The position value can be defined by using the command, DE.

Note: Closed loop operation with a stepper motor is not possible.

Command Summary - Stepper Motor Operation

COMMAND	DESCRIPTION
DE	Define Encoder Position (When using an encoder)
DP	Define Reference Position and Step Count Register
IT	Motion Profile Smoothing - Independent Time Constant
KS	Stepper Motor Smoothing
MT	Motor Type (2,-2,2.5 or -2.5 for stepper motors)
RP	Report Commanded Position
TD	Report number of step pulses generated by controller
TP	Tell Position of Encoder

Operand Summary - Stepper Motor Operation

OPERAND	DESCRIPTION
_DEx	Contains the value of the step count register for the 'x' axis
_DPx	Contains the value of the main encoder for the 'x' axis
_ITx	Contains the value of the Independent Time constant for the 'x' axis
_KSx	Contains the value of the Stepper Motor Smoothing Constant for the 'x' axis
_MTx	Contains the motor type value for the 'x' axis
_RPx	Contains the commanded position generated by the profiler for the 'x' axis
_TDx	Contains the value of the step count register for the 'x' axis
_TPx	Contains the value of the main encoder for the 'x' axis

Stepper Position Maintenance Mode (SPM)

The Galil controller can be set into the Stepper Position Maintenance (SPM) mode to handle the event of stepper motor position error. The mode looks at position feedback from the main encoder and compares it to the commanded step pulses. The position information is used to determine if there is any significant difference between the commanded and the actual motor positions. If such error is detected, it is updated into a command value for operator use. In addition, the SPM mode can be used as a method to correct for friction at the end of a microstepping move. This capability provides closed-loop control at the application program level. SPM mode can be used with Galil and non-Galil step drives.

SPM mode is configured, executed, and managed with seven commands. This mode also utilizes the #POSERR automatic subroutine allowing for automatic user-defined handling of an error event.

Internal Controller Commands (user can query):

QS Error Magnitude (pulses)

User Configurable Commands (user can query & change):

OE Profiler Off-On Error
YA Step Drive Resolution (pulses / full motor step)
YB Step Motor Resolution (full motor steps / revolution)
YC Encoder Resolution (counts / revolution)
YR Error Correction (pulses)
YS Stepper Position Maintenance enable, status

A pulse is defined by the resolution of the step drive being used. Therefore, one pulse could be a full step, a half step or a microstep.

When a Galil controller is configured for step motor operation, the step pulse output by the controller is internally fed back to the auxiliary encoder register. For SPM the feedback encoder on the stepper will connect to the main encoder port. Enabling the SPM mode on a controller with YS=1 executes an internal monitoring of the auxiliary and main encoder registers for that axis or axes. Position error is then tracked in step pulses between these two registers (QS command).

$$QS = TD - \frac{TP \times YA \times YB}{YC}$$

Where TD is the auxiliary encoder register(step pulses) and TP is the main encoder register(feedback encoder). Additionally, YA defines the step drive resolution where YA = 1 for full stepping or YA = 2 for half stepping. The full range of YA is up to YA = 9999 for microstepping drives.

Error Limit

The value of QS is internally monitored to determine if it exceeds a preset limit of three full motor steps. Once the value of QS exceeds this limit, the controller then performs the following actions:

1. The motion is maintained or is stopped, depending on the setting of the OE command. If OE=0 the axis stays in motion, if OE=1 the axis is stopped.
2. YS is set to 2, which causes the automatic subroutine labeled #POSERR to be executed.

Correction

A correction move can be commanded by assigning the value of QS to the YR correction move command. The correction move is issued only after the axis has been stopped. After an error correction move has completed and

QS is less than three full motor steps, the YS error status bit is automatically reset back to 1; indicating a cleared error.

Example: SPM Mode Setup

The following code demonstrates what is necessary to set up SPM mode for a full step drive, a half step drive, and a 1/64th microstepping drive for an axis with a 1.8° step motor and 4000 count/rev encoder. Note the necessary difference is with the YA command.

Full-Stepping Drive, X axis:

```
#SETUP
OE1;          Set the profiler to stop axis upon error
KS16;         Set step smoothing
MT-2;        Motor type set to stepper
YA1;         Step resolution of the full-step drive
YB200;       Motor resolution (full steps per revolution)
YC4000;      Encoder resolution (counts per revolution)
SHX;         Enable axis
WT50;        Allow slight settle time
YS1;         Enable SPM mode
```

Half-Stepping Drive, X axis:

```
#SETUP
OE1;          Set the profiler to stop axis upon error
KS16;         Set step smoothing
MT-2;        Motor type set to stepper
YA2;         Step resolution of the half-step drive
YB200;       Motor resolution (full steps per revolution)
YC4000;      Encoder resolution (counts per revolution)
SHX;         Enable axis
WT50;        Allow slight settle time
YS1;         Enable SPM mode
```

1/64th Step Microstepping Drive, X axis:

```
#SETUP
OE1;          Set the profiler to stop axis upon error
KS16;         Set step smoothing
MT-2;        Motor type set to stepper
YA64;        Step resolution of the microstepping drive
YB200;       Motor resolution (full steps per revolution)
YC4000;      Encoder resolution (counts per revolution)
SHX;         Enable axis
WT50;        Allow slight settle time
YS1;         Enable SPM mode
```

Example: Error Correction

The following code demonstrates what is necessary to set up SPM mode for the X axis, detect error, stop the motor, correct the error, and return to the main code. The drive is a full step drive, with a 1.8° step motor and 4000 count/rev encoder.

```
#SETUP
OE1;           Set the profiler to stop axis upon error
KS16;         Set step smoothing
MT-2,-2,-2,-2; Motor type set to stepper
YA2;         Step resolution of the drive
YB200;        Motor resolution (full steps per revolution)
YC4000;       Encoder resolution (counts per revolution)
SHX;         Enable axis
WT100;        Allow slight settle time

#MOTION
SP512;        Set the speed
PR1000;       Prepare mode of motion
BGX;         Begin motion
#LOOP;JP#LOOP; Keep thread zero alive for #POSERR to run in

REM When error occurs, the axis will stop due to OE1. In
REM #POSERR, query the status YS and the error QS, correct,
REM and return to the main code.

#POSERR;      Automatic subroutine is called when YS=2
WT100;        Wait helps user see the correction
spsave=_SPX; Save current speed setting
JP#RETURN,_YSX<>2; Return to thread zero if invalid error
SP64;         Set slow speed setting for correction
MG"ERROR= ",_QSX
YRX=_QSX;     Else, error is valid, use QS for correction
MCX;         Wait for motion to complete
MG"CORRECTED, ERROR NOW= ",_QSX
WT100;        Wait helps user see the correction

#RETURN
SPX=spsave;   Return the speed to previous setting
REO;          Return from #POSERR
```

Example: Friction Correction

The following example illustrates how the SPM mode can be useful in correcting for X axis friction after each move when conducting a reciprocating motion. The drive is a 1/64th microstepping drive with a 1.8° step motor and 4000 count/rev encoder.

```
#SETUP;       Set the profiler to continue upon error
KS16;         Set step smoothing
MT-2,-2,-2,-2; Motor type set to stepper
YA64;         Step resolution of the microstepping drive
YB200;        Motor resolution (full steps per revolution)
```



```

YC4000;           Encoder resolution (counts per revolution)
SHX;             Enable axis
WT50;           Allow slight settle time
YS1;           Enable SPM mode

#MOTION;        Perform motion
SP16384;       Set the speed
PR10000;       Prepare mode of motion
BGX;           Begin motion
MCX
JS#CORRECT;    Move to correction
#MOTION2
SP16384;       Set the speed
PR-10000;     Prepare mode of motion
BGX;           Begin motion
MCX
JS#CORRECT;    Move to correction
JF#MOTION
#CORRECT;      Correction code
spx=_SPX
#LOOP;         Save speed value
SP2048;        Set a new slow correction speed
WT100;         Stabilize
JF#END,@ABS[_Q SX]<10; End correction if error is within defined tolerance
YRX=_Q SX;     Correction move
MCX
WT100;         Stabilize
JF#LOOP;       Keep correcting until error is within tolerance
#END;          End #CORRECT subroutine, returning to code
SPX=spx
EN

```

Dual Loop (Auxiliary Encoder)

The DMC-40x0 provides an interface for a second encoder for each axis except for axes configured for stepper motor operation and axis used in circular compare. When used, the second encoder is typically mounted on the motor or the load, but may be mounted in any position. The most common use for the second encoder is backlash compensation, described below.

The second encoder may be a standard quadrature type, or it may provide pulse and direction. The controller also offers the provision for inverting the direction of the encoder rotation. The main and the auxiliary encoders are configured with the CE command. The command form is CE x,y,z,w (or a,b,c,d,e,f,g,h for controllers with more than 4 axes) where the parameters x,y,z,w each equal the sum of two integers m and n. m configures the main encoder and n configures the auxiliary encoder.

Using the CE Command

m=	Main Encoder	n=	Second Encoder
0	Normal quadrature	0	Normal quadrature
1	Pulse & direction	4	Pulse & direction

2	Reverse quadrature	8	Reversed quadrature
3	Reverse pulse & direction	12	Reversed pulse & direction

For example, to configure the main encoder for reversed quadrature, m=2, and a second encoder of pulse and direction, n=4, the total is 6, and the command for the X axis is:

```
CE 6
```

Additional Commands for the Auxiliary Encoder

The command, DE x,y,z,w, can be used to define the position of the auxiliary encoders. For example,

```
DE 0,500,-30,300
```

sets their initial values. The positions of the auxiliary encoders may be interrogated with the command, DE?. For example:

```
DE ?, , ?
```

returns the value of the X and Z auxiliary encoders.

The auxiliary encoder position may be assigned to variables with the instructions

```
V1= _DEX
```

The command, TD XYZW, returns the current position of the auxiliary encoder.

The command, DV 1,1,1,1, configures the auxiliary encoder to be used for backlash compensation.

Backlash Compensation

There are two methods for backlash compensation using the auxiliary encoders:

1. Continuous dual loop
2. Sampled dual loop

To illustrate the problem, consider a situation in which the coupling between the motor and the load has a backlash. To compensate for the backlash, position encoders are mounted on both the motor and the load.

The continuous dual loop combines the two feedback signals to achieve stability. This method requires careful system tuning, and depends on the magnitude of the backlash. However, once successful, this method compensates for the backlash continuously.

The second method, the sampled dual loop, reads the load encoder only at the end point and performs a correction. This method is independent of the size of the backlash. However, it is effective only in point-to-point motion systems which require position accuracy only at the endpoint.

Continuous Dual Loop - Example

Connect the load encoder to the main encoder port and connect the motor encoder to the dual encoder port. The dual loop method splits the filter function between the two encoders. It applies the KP (proportional) and KI (integral) terms to the position error, based on the load encoder, and applies the KD (derivative) term to the motor encoder. This method results in a stable system.

The dual loop method is activated with the instruction DV (Dual Velocity), where

```
DV 1,1,1,1
```

activates the dual loop for the four axes and

```
DV 0,0,0,0
```

disables the dual loop.

Note: that the dual loop compensation depends on the backlash magnitude, and in extreme cases will not stabilize the loop. The proposed compensation procedure is to start with $KP=0$, $KI=0$ and to maximize the value of KD under the condition DV1. Once KD is found, increase KP gradually to a maximum value, and finally, increase KI , if necessary.

Sampled Dual Loop - Example

In this example, we consider a linear slide which is run by a rotary motor via a lead screw. Since the lead screw has a backlash, it is necessary to use a linear encoder to monitor the position of the slide. For stability reasons, it is best to use a rotary encoder on the motor.

Connect the rotary encoder to the X-axis and connect the linear encoder to the auxiliary encoder of X. Assume that the required motion distance is one inch, and that this corresponds to 40,000 counts of the rotary encoder and 10,000 counts of the linear encoder.

The design approach is to drive the motor a distance, which corresponds to 40,000 rotary counts. Once the motion is complete, the controller monitors the position of the linear encoder and performs position corrections.

This is done by the following program.

INSTRUCTION	INTERPRETATION
#DUALOOP	Label
CE 0	Configure encoder
DE0	Set initial value
PR 40000	Main move
BGX	Start motion
#Correct	Correction loop
AMX	Wait for motion completion
V1=10000-_DEX	Find linear encoder error
V2=-_TEX/4+V1	Compensate for motor error
JF#END,@ABS[V2]<2	Exit if error is small
PR V2*4	Correction move
BGX	Start correction
JP#CORRECT	Repeat
#END	
EN	

Motion Smoothing

The DMC-40x0 controller allows the smoothing of the velocity profile to reduce the mechanical vibration of the system.

Trapezoidal velocity profiles have acceleration rates which change abruptly from zero to maximum value. The discontinuous acceleration results in jerk which causes vibration. The smoothing of the acceleration profile leads to a continuous acceleration profile and reduces the mechanical shock and vibration.

Using the IT Command:



When operating with servo motors, motion smoothing can be accomplished with the IT command. This command filters the acceleration and deceleration functions to produce a smooth velocity profile. The resulting velocity profile, has continuous acceleration and results in reduced mechanical vibrations.

The smoothing function is specified by the following commands:

IT x,y,z,w Independent time constant

The command, IT, is used for smoothing independent moves of the type JG, PR, PA and to smooth vector moves of the type VM and LM.

The smoothing parameters, x,y,z,w and n are numbers between 0 and 1 and determine the degree of filtering. The maximum value of 1 implies no filtering, resulting in trapezoidal velocity profiles. Smaller values of the smoothing parameters imply heavier filtering and smoother moves.

The following example illustrates the effect of smoothing. Fig. 6.15 shows the trapezoidal velocity profile and the modified acceleration and velocity.

Note that the smoothing process results in longer motion time.

Example - Smoothing

```

PR 20000      Position
AC 100000    Acceleration
DC 100000    Deceleration
SP 5000      Speed
IT .5        Filter for smoothing
BG X         Begin
    
```

ACCELERATION

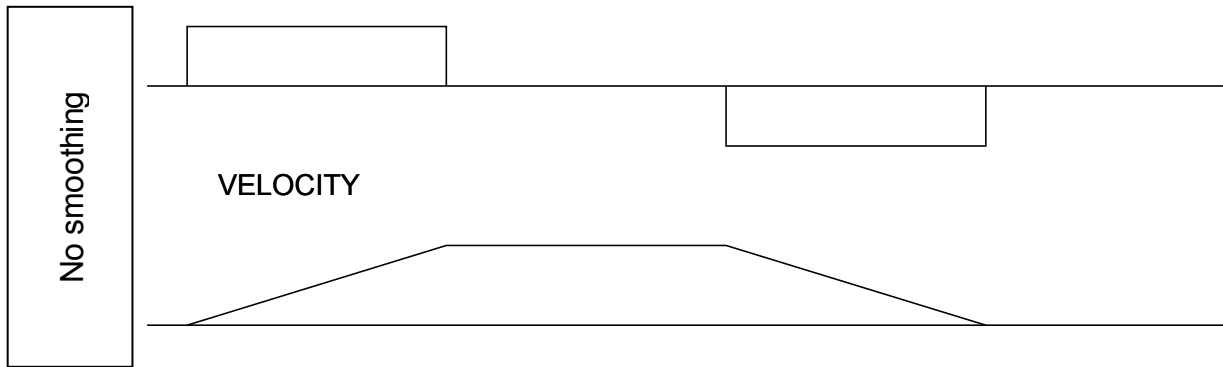

No smoothing

ACCELERATION

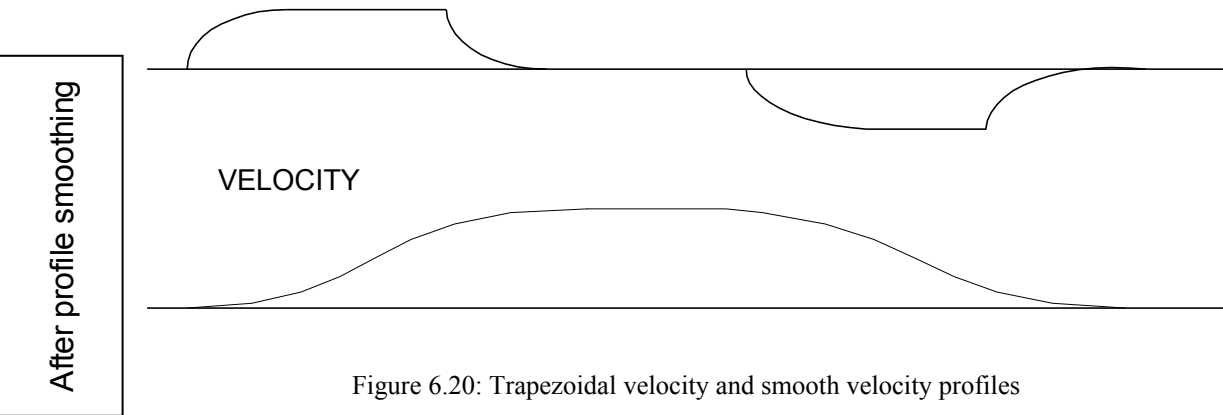

After profile smoothing

Figure 6.20: Trapezoidal velocity and smooth velocity profiles

Using the KS Command (Step Motor Smoothing):



When operating with step motors, motion smoothing can be accomplished with the command, KS. The KS command smoothes the frequency of step motor pulses. Similar to the command IT, this produces a smooth velocity profile.

The step motor smoothing is specified by the following command:

KS x,y,z,w where x,y,z,w is an integer from 0.25 to 64 and represents the amount of smoothing

The smoothing parameters, x,y,z,w and n are numbers between 0.25 and 64 and determine the degree of filtering. The minimum value of 0.25 implies no filtering, resulting in trapezoidal velocity profiles. Larger values of the smoothing parameters imply heavier filtering and smoother moves.

Note that KS is valid only for step motors.

Homing

The Find Edge (FE) and Home (HM) instructions may be used to home the motor to a mechanical reference. This reference is connected to the Home input line. The HM command initializes the motor to the encoder index pulse in addition to the Home input. The configure command (CN) is used to define the polarity of the home input.

The Find Edge (FE) instruction is useful for initializing the motor to a home switch. The home switch is connected to the Homing Input. When the Find Edge command and Begin is used, the motor will accelerate up to the slew speed and slew until a transition is detected on the Homing line. The motor will then decelerate to a stop. A high deceleration value must be input before the find edge command is issued for the motor to decelerate rapidly after sensing the home switch. The Home (HM) command can be used to position the motor on the index pulse after the home switch is detected. This allows for finer positioning on initialization. The HM command and BG command causes the following sequence of events to occur.

Stage 1:

Upon begin, the motor accelerates to the slew speed specified by the JG or SP commands. The direction of its motion is determined by the state of the homing input. If `_HMX` reads 1 initially, the motor will go in the reverse direction first (direction of decreasing encoder counts). If `_HMX` reads 0 initially, the motor will go in the forward direction first. CN is the command used to define the polarity of the home input. With CN,-1 (the default value) a normally open switch will make `_HMX` read 1 initially, and a normally closed switch will make `_HMX` read zero. Furthermore, with CN,1 a normally open switch will make `_HMX` read 0 initially, and a normally closed switch will make `_HMX` read 1. Therefore, the CN command will need to be configured properly to ensure the correct direction of motion in the home sequence.

Upon detecting the home switch changing state, the motor begins decelerating to a stop.

Note: The direction of motion for the FE command also follows these rules for the state of the home input.

Stage 2:

The motor then traverses at HV counts/sec in the opposite direction of Stage 1 until the home switch toggles again. If Stage 3 is in the opposite direction of Stage 2, the motor will stop immediately at this point and change direction. If Stage 2 is in the same direction as Stage 3, the motor will never stop, but will smoothly continue into Stage 3.

Stage 3:

The motor traverses forward at HV counts/sec until the encoder index pulse is detected. The motor then decelerates to a stop and goes back to the index.

The DMC-40x0 defines the home position as the position at which the index was detected and sets the encoder reading at this point to zero.

The 4 different motion possibilities for the home sequence are shown in the following table.

Switch Type	CN Setting	Initial HMX state	Direction of Motion		
			Stage 1	Stage 2	Stage 3
Normally Open	CN,-1	1	Reverse	Forward	Forward
Normally Open	CN,1	0	Forward	Reverse	Forward
Normally Closed	CN,-1	0	Forward	Reverse	Forward
Normally Closed	CN,1	1	Reverse	Forward	Forward

Example: Homing

<u>Instruction</u>	<u>Interpretation</u>
#HOME	Label
CN,-1	Configure the polarity of the home input
AC 1000000	Acceleration Rate
DC 1000000	Deceleration Rate
SP 5000	Speed for Home Search
HM	Home
BG	Begin Motion
AM	After Complete
MG "AT HOME"	Send Message
EN	End

Figure 6.21 shows the velocity profile from the homing sequence of the example program above. For this profile, the switch is normally closed and CN,-1.

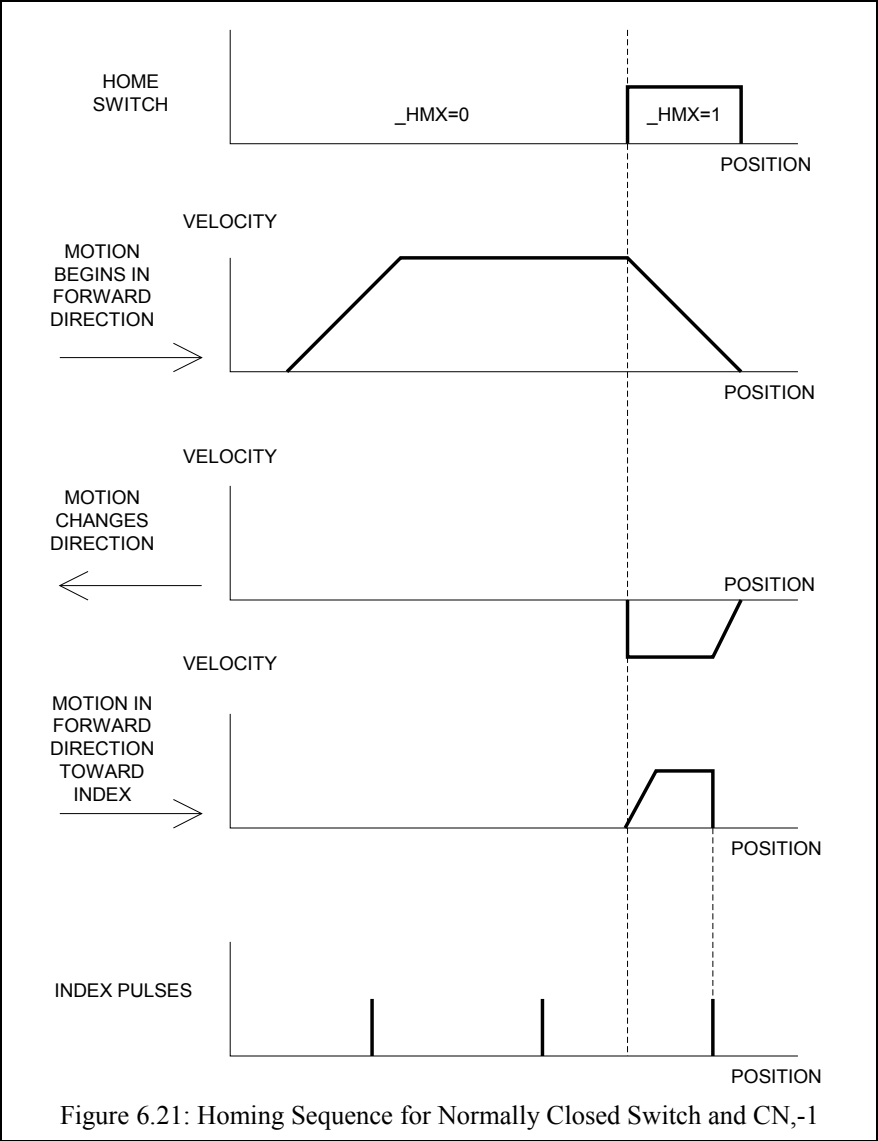

Example: Find Edge

#EDGE	Label
AC 2000000	Acceleration rate
DC 2000000	Deceleration rate
SP 8000	Speed
FE	Find edge command
BG	Begin motion
AM	After complete
MG "FOUND HOME"	Send message
DP 0	Define position as 0
EN	End

Command Summary - Homing Operation

command	description
FE XYZW	Find Edge Routine. This routine monitors the Home Input
FI XYZW	Find Index Routine - This routine monitors the Index Input
HM XYZW	Home Routine - This routine combines FE and FI as Described Above
SC XYZW	Stop Code
TS XYZW	Tell Status of Switches and Inputs

Operand Summary - Homing Operation

operand	Description
_HMx	Contains the value of the state of the Home Input
_SCx	Contains stop code
_TSx	Contains status of switches and inputs

High Speed Position Capture (The Latch Function)

Often it is desirable to capture the position precisely for registration applications. The DMC-40x0 provides a position latch feature. This feature allows the position of the main or auxiliary encoders of X,Y,Z or W to be captured within 25 microseconds of an external low input signal (or index pulse). The general inputs 1 through 4 and 9 thru 12 correspond to each axis.

1 through 4:	9 through 12
IN1 X-axis latch	IN9 E-axis latch
IN2 Y-axis latch	IN10 F-axis latch
IN3 Z-axis latch	IN11 G-axis latch
IN4 W-axis latch	IN12 H-axis latch

Note: To insure a position capture within 25 microseconds, the input signal must be a transition from high to low.

The DMC-40x0 software commands, AL and RL, are used to arm the latch and report the latched position. The steps to use the latch are as follows:

1. Give the AL XYZW command or ABCDEFGH for DMC-4080, to arm the latch for the main encoder and ALSXSYSZSW for the auxiliary encoders.
2. Test to see if the latch has occurred (Input goes low) by using the _AL X or Y or Z or W command. Example, V1=_ALX returns the state of the X latch into V1. V1 is 1 if the latch has not occurred.
3. After the latch has occurred, read the captured position with the RL XYZW command or _RL XYZW.

Note: The latch must be re-armed after each latching event.

Example:

```

#Latch           Latch program
JG,5000          Jog Y
BG Y            Begin motion on Y axis
AL Y            Arm Latch for Y axis
#Wait           #Wait label for loop
JP #Wait,_ALY=1 Jump to #Wait label if latch has not occurred
Result=_RLY     Set value of variable 'Result' equal to the report position of y axis
Result=         Print result
EN              End

```

Fast Update Rate Mode

The DMC-40x0 can operate with much faster servo update rates than the default of every millisecond. This mode is known as 'fast mode' and allows the controller to operate with the following update rates:

DMC-4010	31.25 μ sec
DMC-4020	31.25 μ sec
DMC-4030	62.5 μ sec
DMC-4040	62.5 μ sec
DMC-4050	93.75 μ sec
DMC-4060	93.75 μ sec
DMC-4070	125 μ sec
DMC-4080	125 μ sec

In order to run the DMC-40x0 motion controller in fast mode, the fast firmware must be uploaded. This can be done through the GalilTools communication software. The fast firmware is included with the original DMC-40x0 utilities.

In order to set the desired update rates, use the command TM.

When the controller is operating with the fast firmware, the following functions are **disabled**:

- Gearing mode
- Ecam mode
- Pole (PL)
- Analog Feedback (AF)
- Stepper Motor Operation (MT 2,-2,2.5,-2.5)
- Trippoints in thread 2-8
- Tell Velocity Interrogation Command (TV)
- Aux Encoders (TD)
- Dual Velocity (DV)
- Peak Torque Limit (TK)
- Notch Filter (NB, NF, NZ)
- PVT Mode (PV, BT)

Chapter 7 Application Programming

Overview

The DMC-40x0 provides a powerful programming language that allows users to customize the controller for their particular application. Programs can be downloaded into the DMC-40x0 memory freeing the host computer for other tasks. However, the host computer can send commands to the controller at any time, even while a program is being executed. Only ASCII commands can be used for application programming.

In addition to standard motion commands, the DMC-40x0 provides commands that allow the DMC-40x0 to make its own decisions. These commands include conditional jumps, event triggers and subroutines. For example, the command JP#LOOP, n<10 causes a jump to the label #LOOP if the variable n is less than 10.

For greater programming flexibility, the DMC-40x0 provides user-defined variables, arrays and arithmetic functions. For example, with a cut-to-length operation, the length can be specified as a variable in a program which the operator can change as necessary.

The following sections in this chapter discuss all aspects of creating applications programs. The program memory size is 80 characters x 2000 lines.

Using the DMC-40x0 Editor to Enter Programs

The GalilTools software package provides an editor and utilities that allow the upload and download of DMC programs to the motion controller.

Application programs for the DMC-40x0 may also be created and edited locally using the DMC-40x0.

The DMC-40x0 provides a line Editor for entering and modifying programs. The Edit mode is entered with the ED instruction. (Note: The ED command can only be given when the controller is in the non-edit mode, which is signified by a colon prompt).

In the Edit Mode, each program line is automatically numbered sequentially starting with 000. If no parameter follows the ED command, the editor prompter will default to the last line of the last program in memory. If desired, the user can edit a specific line number or label by specifying a line number or label following ED.

```
ED                Puts Editor at end of last program
:ED 5            Puts Editor at line 5
:ED #BEGIN      Puts Editor at label #BEGIN
```

Line numbers appear as 000,001,002 and so on. Program commands are entered following the line numbers. Multiple commands may be given on a single line as long as the total number of characters doesn't exceed 80 characters per line.

While in the Edit Mode, the programmer has access to special instructions for saving, inserting and deleting program lines. These special instructions are listed below:

Edit Mode Commands

<RETURN>

Typing the return key causes the current line of entered instructions to be saved. The editor will automatically advance to the next line. Thus, hitting a series of <RETURN> will cause the editor to advance a series of lines. Note, changes on a program line will not be saved unless a <return> is given.

<cntrl>P

The <cntrl>P command moves the editor to the previous line.

<cntrl>I

The <cntrl>I command inserts a line above the current line. For example, if the editor is at line number 2 and <cntrl>I is applied, a new line will be inserted between lines 1 and 2. This new line will be labeled line 2. The old line number 2 is renumbered as line 3.

<cntrl>D

The <cntrl>D command deletes the line currently being edited. For example, if the editor is at line number 2 and <cntrl>D is applied, line 2 will be deleted. The previous line number 3 is now renumbered as line number 2.

<cntrl>Q

The <cntrl>Q quits the editor mode. In response, the DMC-40x0 will return a colon.

After the Edit session is over, the user may list the entered program using the LS command. If no operand follows the LS command, the entire program will be listed. The user can start listing at a specific line or label using the operand n. A command and new line number or label following the start listing operand specifies the location at which listing is to stop.

Example:

Instruction	Interpretation
:LS	List entire program
:LS 5	Begin listing at line 5
:LS 5,9	List lines 5 thru 9
:LS #A,9	List line label #A thru line 9
:LS #A, #A +5	List line label #A and additional 5 lines

Program Format

A DMC-40x0 program consists of DMC instructions combined to solve a machine control application. Action instructions, such as starting and stopping motion, are combined with Program Flow instructions to form the complete program. Program Flow instructions evaluate real-time conditions, such as elapsed time or motion complete, and alter program flow accordingly.

Each DMC-40x0 instruction in a program must be separated by a delimiter. Valid delimiters are the semicolon (;) or carriage return. The semicolon is used to separate multiple instructions on a single program line where the maximum number of instructions on a line is limited by 80 characters. A carriage return enters the final command on a program line.

Using Labels in Programs

All DMC-40x0 programs must begin with a label and end with an End (EN) statement. Labels start with the pound (#) sign followed by a maximum of seven characters. The first character must be a letter; after that, numbers are permitted. Spaces are not permitted.

The maximum number of labels which may be defined is 510.

Valid labels

```
#BEGIN
#SQUARE
#X1
#BEGIN1
```

Invalid labels

```
#lSquare
#123
```

A Simple Example Program:

```
#START          Beginning of the Program
PR 10000,20000  Specify relative distances on X and Y axes
BG XY          Begin Motion
AM            Wait for motion complete
WT 2000       Wait 2 sec
JP #START     Jump to label START
EN            End of Program
```

The above program moves X and Y 10000 and 20000 units. After the motion is complete, the motors rest for 2 seconds. The cycle repeats indefinitely until the stop command is issued.

Special Labels

The DMC-40x0 have some special labels, which are used to define input interrupt subroutines, limit switch subroutines, error handling subroutines, and command error subroutines. See section on ...

```
#ININT          Label for Input Interrupt subroutine
#LIMSWI        Label for Limit Switch subroutine
#POSERR        Label for excess Position Error subroutine
#MCTIME        Label for timeout on Motion Complete trip point
#CMDERR        Label for incorrect command subroutine
```

Commenting Programs

Using the command, NO or Apostrophe (‘)

The DMC-40x0 provides a command, NO, for commenting programs or single apostrophe. This command allows the user to include up to 78 characters on a single line after the NO command and can be used to include comments from the programmer as in the following example:

```
#PATH
‘ 2-D CIRCULAR PATH
VMXY
‘ VECTOR MOTION ON X AND Y
VS 10000
‘ VECTOR SPEED IS 10000
VP -4000,0
‘ BOTTOM LINE
CR 1500,270,-180
‘ HALF CIRCLE MOTION
VP 0,3000
‘ TOP LINE
CR 1500,90,-180
```

```

' HALF CIRCLE MOTION
VE
' END VECTOR SEQUENCE
BGS
' BEGIN SEQUENCE MOTION
EN
' END OF PROGRAM

```

Note: The NO command is an actual controller command. Therefore, inclusion of the NO commands will require process time by the controller.

Executing Programs - Multitasking

The DMC-40x0 can run up to 8 independent programs simultaneously. These programs are called threads and are numbered 0 through 7, where 0 is the main thread. Multitasking is useful for executing independent operations such as PLC functions that occur independently of motion.

The main thread differs from the others in the following ways:

1. Only the main thread, thread 0, may use the input command, IN.
2. When input interrupts are implemented for limit switches, position errors or command errors, the subroutines are executed as thread 0.

To begin execution of the various programs, use the following instruction:

```
XQ #A, n
```

Where n indicates the thread number. To halt the execution of any thread, use the instruction

```
HX n
```

where n is the thread number.

Note that both the XQ and HX commands can be performed by an executing program.

The example below produces a waveform on Output 1 independent of a move.

```

#TASK1                Task1 label
AT0                   Initialize reference time
CB1                   Clear Output 1
#LOOP1                Loop1 label
AT 10                 Wait 10 msec from reference time
SB1                   Set Output 1
AT -40                Wait 40 msec from reference time, then initialize reference
CB1                   Clear Output 1
JP #LOOP1             Repeat Loop1
#TASK2                Task2 label
XQ #TASK1,1           Execute Task1
#LOOP2                Loop2 label
PR 1000               Define relative distance
BGX                   Begin motion
AMX                   After motion done
WT 10                 Wait 10 msec
JP #LOOP2,@IN[2]=1    Repeat motion unless Input 2 is low
HX                    Halt all tasks

```

The program above is executed with the instruction XQ #TASK2,0 which designates TASK2 as the main thread (i.e. Thread 0). #TASK1 is executed within TASK2.

Debugging Programs

The DMC-40x0 provides commands and operands which are useful in debugging application programs. These commands include interrogation commands to monitor program execution, determine the state of the controller and the contents of the controllers program, array, and variable space. Operands also contain important status information which can help to debug a program.

Trace Commands

The trace command causes the controller to send each line in a program to the host computer immediately prior to execution. Tracing is enabled with the command, TR1. TR0 turns the trace function off. Note: When the trace function is enabled, the line numbers as well as the command line will be displayed as each command line is executed.

NOTE: When the trace function is enabled, the line numbers as well as the command line will be displayed as each command line is executed.

Data which is output from the controller is stored in the output UART. The UART buffer can store up to 512 characters of information. In normal operation, the controller places output into the FIFO buffer. When the trace mode is enabled, the controller will send information to the UART buffer at a very high rate. In general, the UART will become full because the hardware handshake line will halt serial data until the correct data is read. When the UART becomes full, program execution will be delayed until it is cleared. If the user wants to avoid this delay, the command CW,1 can be given. This command causes the controller to throw away the data which can not be placed into the FIFO. In this case, the controller does not delay program execution.

Error Code Command

When there is a program error, the DMC-40x0 halts the program execution at the point where the error occurs. To display the last line number of program execution, issue the command, MG_ED.

The user can obtain information about the type of error condition that occurred by using the command, TC1. This command reports back a number and a text message which describes the error condition. The command, TC0 or TC, will return the error code without the text message. For more information about the command, TC, see the Command Reference.

Stop Code Command

The status of motion for each axis can be determined by using the stop code command, SC. This can be useful when motion on an axis has stopped unexpectedly. The command SC will return a number representing the motion status. See the command reference for further information.

RAM Memory Interrogation Commands

For debugging the status of the program memory, array memory, or variable memory, the DMC-40x0 has several useful commands. The command, DM ?, will return the number of array elements currently available. The command, DA ?, will return the number of arrays which can be currently defined. For example, a standard DMC-14010 will have a maximum of 16000 array elements in up to 30 arrays. If an array of 100 elements is defined, the command DM ? will return the value 15900 and the command DA ? will return 29.

To list the contents of the variable space, use the interrogation command LV (List Variables). To list the contents of array space, use the interrogation command, LA (List Arrays). To list the contents of the Program space, use the interrogation command, LS (List). To list the application program labels only, use the interrogation command, LL (List Labels).

Operands

In general, all operands provide information which may be useful in debugging an application program. Below is a list of operands which are particularly valuable for program debugging. To display the value of an operand, the message command may be used. For example, since the operand, `_ED` contains the last line of program execution, the command `MG _ED` will display this line number.

- `_ED` contains the last line of program execution. Useful to determine where program stopped.
- `_DL` contains the number of available labels.
- `_UL` contains the number of available variables.
- `_DA` contains the number of available arrays.
- `_DM` contains the number of available array elements.
- `_AB` contains the state of the Abort Input
- `_LFx` contains the state of the forward limit switch for the 'x' axis
- `_LRx` contains the state of the reverse limit switch for the 'x' axis

Debugging Example:

The following program has an error. It attempts to specify a relative movement while the X-axis is already in motion. When the program is executed, the controller stops at line 003. The user can then query the controller using the command, `TC1`. The controller responds with the corresponding explanation:

```
:ED                Edit Mode
000 #A             Program Label
001 PR1000         Position Relative 1000
002 BGX           Begin
003 PR5000         Position Relative 5000
004 EN            End
<cntrl> Q         Quit Edit Mode
:XQ #A            Execute #A
?003 PR5000       Error on Line 3
:TC1              Tell Error Code
?7 Command not valid Command not valid while running
while running.
:ED 3             Edit Line 3
003 AMX;PR5000;BGX Add After Motion Done
<cntrl> Q         Quit Edit Mode
:XQ #A            Execute #A
```

Program Flow Commands

The DMC-40x0 provides instructions to control program flow. The controller program sequencer normally executes program instructions sequentially. The program flow can be altered with the use of event triggers, trippoints, and conditional jump statements.

Event Triggers & Trippoints

To function independently from the host computer, the DMC-40x0 can be programmed to make decisions based on the occurrence of an event. Such events include waiting for motion to be complete, waiting for a specified amount of time to elapse, or waiting for an input to change logic levels.

The DMC-40x0 provides several event triggers that cause the program sequencer to halt until the specified event occurs. Normally, a program is automatically executed sequentially one line at a time. When an event trigger instruction is decoded, however, the actual program sequence is halted. The program sequence does not continue until the event trigger is “tripped”. For example, the motion complete trigger can be used to separate two move sequences in a program. The commands for the second move sequence will not be executed until the motion is complete on the first motion sequence. In this way, the controller can make decisions based on its own status or external events without intervention from a host computer.

DMC-40x0 Event Triggers

Command	Function
AM X Y Z W or S (A B C D E F G H)	Halts program execution until motion is complete on the specified axes or motion sequence(s). AM with no parameter tests for motion complete on all axes. This command is useful for separating motion sequences in a program.
AD X or Y or Z or W (A or B or C or D or E or F or G or H)	Halts program execution until position command has reached the specified relative distance from the start of the move. Only one axis may be specified at a time.
AR X or Y or Z or W (A or B or C or D or E or F or G or H)	Halts program execution until after specified distance from the last AR or AD command has elapsed. Only one axis may be specified at a time.
AP X or Y or Z or W (A or B or C or D or E or F or G or H)	Halts program execution until after absolute position occurs. Only one axis may be specified at a time.
MF X or Y or Z or W (A or B or C or D or E or F or G or H)	Halt program execution until after forward motion reached absolute position. Only one axis may be specified. If position is already past the point, then MF will trip immediately. Will function on geared axis or aux. inputs.
MR X or Y or Z or W (A or B or C or D or E or F or G or H)	Halt program execution until after reverse motion reached absolute position. Only one axis may be specified. If position is already past the point, then MR will trip immediately. Will function on geared axis or aux. inputs.
MC X or Y or Z or W (A or B or C or D or E or F or G or H)	Halt program execution until after the motion profile has been completed and the encoder has entered or passed the specified position. TW x,y,z,w sets timeout to declare an error if not in position. If timeout occurs, then the trippoint will clear and the stop code will be set to 99. An application program will jump to label #MCTIME.
AI +/- n	Halts program execution until after specified input is at specified logic level. n specifies input line. Positive is high logic level, negative is low level. n=1 through 8 for DMC-4010, 4020, 4030, 4040. n=1 through 16 for DMC-4050, 4060, 4070, 4080 Also n= 17-48
AS X Y Z W S (A B C D E F G H)	Halts program execution until specified axis has reached its slew speed.
AT +/-n,m	For m=omitted or 0, halts program execution until n msec from reference time. AT 0 sets reference. AT n waits n msec from reference. AT -n waits n msec from reference and sets new reference after elapsed time. For m=1. Same functionality except that n is number of samples rather than msec

AV n	Halts program execution until specified distance along a coordinated path has occurred.
WT n,m	For m=omitted or 0, halts program execution until specified time in msec has elapsed. For m=1. Same functionality except that n is number of samples rather than msec.

Event Trigger Examples:

Event Trigger - Multiple Move Sequence

The AM trippoint is used to separate the two PR moves. If AM is not used, the controller returns a ? for the second PR command because a new PR cannot be given until motion is complete.

```
#TWO MOVE; '      Label
PR 2000; '        Position Command
BGX; '           Begin Motion
AMX; '           Wait for Motion Complete
PR 4000; '        Next Position Move
BGX; '           Begin 2nd move
EN; '           End program
```

Event Trigger - Set Output after Distance

Set output bit 1 after a distance of 1000 counts from the start of the move. The accuracy of the trippoint is the speed multiplied by the sample period.

```
#SETBIT; '      Label
SP 10000; '     Speed is 10000
PA 20000; '     Specify Absolute position
BGX; '         Begin motion
AD 1000; '     Wait until 1000 counts
SB1; '         Set output bit 1
EN; '         End program
```

Event Trigger - Repetitive Position Trigger

To set the output bit every 10000 counts during a move, the AR trippoint is used as shown in the next example.

```
#TRIP; '      Label
JG 50000; '    Specify Jog Speed
BGX;n=0; '    Begin Motion
#REPEAT; '    # Repeat Loop
AR 10000; '    Wait 10000 counts
TPX; '        Tell Position
SB1; '        Set output 1
WT50; '       Wait 50 msec
CB1; '        Clear output 1
n=n+1; '      Increment counter
JP #REPEAT,n<5; ' Repeat 5 times
STX; '        Stop
EN; '        End
```

Event Trigger - Start Motion on Input

This example waits for input 1 to go low and then starts motion. Note: The AI command actually halts execution of the program until the input occurs. If you do not want to halt the program sequences, you can use the Input Interrupt function (II) or use a conditional jump on an input, such as `JP#GO,@IN[1] = 1.`

```
#INPUT;'          Program Label
AI-1;'           Wait for input 1 low
PR 10000;'       Position command
BGX;'           Begin motion
EN;'            End program
```

Event Trigger - Set output when At speed

```
#ATSPEED;'       Program Label
JG 50000;'       Specify jog speed
AC 10000;'       Acceleration rate
BGX;'           Begin motion
ASX;'           Wait for at slew speed 50000
SB1;'           Set output 1
EN;'            End program
```

Event Trigger - Change Speed along Vector Path

The following program changes the feed rate or vector speed at the specified distance along the vector. The vector distance is measured from the start of the move or from the last AV command.

```
#VECTOR;'        Label
VMXY;VS 5000;'   Coordinated path
VP 10000,20000;' Vector position
VP 20000,30000;' Vector position
VE;'            End vector
BGS;'           Begin sequence
AV 5000;'        After vector distance
VS 1000;'        Reduce speed
EN;'            End
```

Event Trigger - Multiple Move with Wait

This example makes multiple relative distance moves by waiting for each to be complete before executing new moves.

```
#MOVES;'        Label
PR 12000;'       Distance
SP 20000;'       Speed
AC 100000;'      Acceleration
BGX;'           Start Motion
AD 10000;'       Wait a distance of 10,000 counts
SP 5000;'        New Speed
AMX;'           Wait until motion is completed
WT 200;'         Wait 200 ms
PR -10000;'      New Position
SP 30000;'       New Speed
AC 150000;'      New Acceleration
BGX;'           Start Motion
```

```
EN; '                               End
```

Define Output Waveform Using AT

The following program causes Output 1 to be high for 10 msec and low for 40 msec. The cycle repeats every 50 msec.

```
#OUTPUT; '           Program label
AT0; '              Initialize time reference
SB1; '              Set Output 1
#LOOP; '            Loop
AT 10; '            After 10 msec from reference,
CB1; '              Clear Output 1
AT -40; '           Wait 40 msec from reference and reset reference
SB1; '              Set Output 1
JP #LOOP; '         Loop
EN; '              End Program
```

Using AT/WT with non-default TM rates

By default both WT and AT are defined to hold up program execution for 'n' number of milliseconds (WT n or AT n). The second field of both AT and WT can be used to have the program execution be held-up for 'n' number of samples rather than milliseconds. For example WT 400 or WT 400,0 will hold up program execution for 400 msec regardless of what is set for TM. By contrast WT 400,1 will hold up program execution for 400 samples. For the default TM of 1000 the servo update rate is 976us per sample, so the difference between WT n,0 and WT n,1 is minimal. The difference comes when the servo update rate is changed. With a low servo update rate, it is often useful to be able to time loops based upon samples rather than msec, and this is where the “unscaled” WT and AT are useful. For example:

```
#MAIN; '           Label
TM 250; '          250us update rate
#MOVE; '           Label
PRX=1000; '        Position Relative Move
BGX; '             Begin Motion
MCX; '             Wait for motion to complete
WT 2,1; '          Wait 2 samples (500us)
SB1; '             Set bit 1
EN; '             End Program
```

In the above example, without using an unscaled WT, the output would either need to be set directly after the motion was complete, or 2 ms after the motion was complete. By using WT n,1 and a lower TM, greater delay resolution was achieved.

Conditional Jumps

The DMC-40x0 provides Conditional Jump (JP) and Conditional Jump to Subroutine (JS) instructions for branching to a new program location based on a specified condition. The conditional jump determines if a condition is satisfied and then branches to a new location or subroutine. Unlike event triggers, the conditional jump instruction does not halt the program sequence. Conditional jumps are useful for testing events in real-time. They allow the controller to make decisions without a host computer. For example, the DMC-40x0 can decide between two motion profiles based on the state of an input line.

Command Format - JP and JS

FORMAT:	DESCRIPTION
---------	-------------

JS destination, logical condition	Jump to subroutine if logical condition is satisfied
JP destination, logical condition	Jump to location if logical condition is satisfied

The destination is a program line number or label where the program sequencer will jump if the specified condition is satisfied. Note that the line number of the first line of program memory is 0. The comma designates “IF”. The logical condition tests two operands with logical operators.

Logical operators:

OPERATOR	DESCRIPTION
<	less than
>	greater than
=	equal to
<=	less than or equal to
>=	greater than or equal to
<>	not equal

Conditional Statements

The conditional statement is satisfied if it evaluates to any value other than zero. The conditional statement can be any valid DMC-40x0 numeric operand, including variables, array elements, numeric values, functions, keywords, and arithmetic expressions. If no conditional statement is given, the jump will always occur.

Examples:

Number	V1=6
Numeric Expression	V1=V7*6 @ABS[V1]>10
Array Element	V1<Count[2]
Variable	V1<V2
Internal Variable	_TFX=0 _TVX>500
I/O	V1>@AN[2] @IN[1]=0

Multiple Conditional Statements

The DMC-40x0 will accept multiple conditions in a single jump statement. The conditional statements are combined in pairs using the operands “&” and “|”. The “&” operand between any two conditions, requires that both statements must be true for the combined statement to be true. The “|” operand between any two conditions, requires that only one statement be true for the combined statement to be true.

Note: Each condition must be placed in parentheses for proper evaluation by the controller. In addition, the DMC-40x0 executes operations from left to right. See Mathematical and Functional Expressions for more information.

For example, using variables named V1, V2, V3 and V4:

```
JP #TEST, (V1<V2) & (V3<V4)
```

In this example, this statement will cause the program to jump to the label #TEST if V1 is less than V2 and V3 is less than V4. To illustrate this further, consider this same example with an additional condition:

```
JP #TEST, ((V1<V2) & (V3<V4)) | (V5<V6)
```

This statement will cause the program to jump to the label #TEST under two conditions; 1. If V1 is less than V2 and V3 is less than V4. OR 2. If V5 is less than V6.

Using the JP Command:

If the condition for the JP command is satisfied, the controller branches to the specified label or line number and continues executing commands from this point. If the condition is not satisfied, the controller continues to execute the next commands in sequence.

Conditional	Meaning
JP #Loop,COUNT<10	Jump to #Loop if the variable, COUNT, is less than 10
JS #MOVE2,@IN[1]=1	Jump to subroutine #MOVE2 if input 1 is logic level high. After the subroutine MOVE2 is executed, the program sequencer returns to the main program location where the subroutine was called.
JP #BLUE,@ABS[V2]>2	Jump to #BLUE if the absolute value of variable, V2, is greater than 2
JP #C,V1*V7<=V8*V2	Jump to #C if the value of V1 times V7 is less than or equal to the value of V8*V2
JP#A	Jump to #A

Example Using JP command:

Move the X motor to absolute position 1000 counts and back to zero ten times. Wait 100 msec between moves.

#BEGIN	Begin Program
COUNT=10	Initialize loop counter
#LOOP	Begin loop
PA 1000	Position absolute 1000
BGX	Begin move
AMX	Wait for motion complete
WT 100	Wait 100 msec
PA 0	Position absolute 0
BGX	Begin move
AMX	Wait for motion complete
WT 100	Wait 100 msec
COUNT=COUNT-1	Decrement loop counter
JP #LOOP,COUNT>0	Test for 10 times thru loop
EN	End Program

Using If, Else, and Endif Commands

The DMC-40x0 provides a structured approach to conditional statements using IF, ELSE and ENDIF commands.

Using the IF and ENDIF Commands

An IF conditional statement is formed by the combination of an IF and ENDIF command. The IF command has as its arguments one or more conditional statements. If the conditional statement(s) evaluates true, the command interpreter will continue executing commands which follow the IF command. If the conditional statement evaluates false, the controller will ignore commands until the associated ENDIF command is executed OR an ELSE command occurs in the program (see discussion of ELSE command below).

Note: An ENDIF command must always be executed for every IF command that has been executed. It is recommended that the user not include jump commands inside IF conditional statements since this causes re-direction of command execution. In this case, the command interpreter may not execute an ENDIF command.

Using the ELSE Command

The ELSE command is an optional part of an IF conditional statement and allows for the execution of command only when the argument of the IF command evaluates False. The ELSE command must occur after an IF command and has no arguments. If the argument of the IF command evaluates false, the controller will skip commands until

the ELSE command. If the argument for the IF command evaluates true, the controller will execute the commands between the IF and ELSE command.

Nesting IF Conditional Statements

The DMC-40x0 allows for IF conditional statements to be included within other IF conditional statements. This technique is known as 'nesting' and the DMC-40x0 allows up to 255 IF conditional statements to be nested. This is a very powerful technique allowing the user to specify a variety of different cases for branching.

Command Format - IF, ELSE and ENDIF

Format:	Description
IF conditional statement(s)	Execute commands proceeding IF command (up to ELSE command) if conditional statement(s) is true, otherwise continue executing at ENDIF command or optional ELSE command.
ELSE	Optional command. Allows for commands to be executed when argument of IF command evaluates not true. Can only be used with IF command.
ENDIF	Command to end IF conditional statement. Program must have an ENDIF command for every IF command.

Example using IF, ELSE and ENDIF:

```

#TEST                               Begin Main Program "TEST"
II,,3                               Enable input interrupts on input 1 and input 2
MG "WAITING FOR INPUT 1, INPUT 2"    Output message
#LOOP                                Label to be used for endless loop
JP #LOOP                             Endless loop
EN                                   End of main program
#ININT                               Input Interrupt Subroutine
IF (@IN[1]=0)                       IF conditional statement based on input 1
IF (@IN[2]=0)                       2nd IF conditional statement executed if 1st IF conditional true
MG "INPUT 1 AND INPUT 2 ARE ACTIVE"  Message to be executed if 2nd IF conditional is true
ELSE                                 ELSE command for 2nd IF conditional statement
MG "ONLY INPUT 1 IS ACTIVE"         Message to be executed if 2nd IF conditional is false
ENDIF                               End of 2nd conditional statement
ELSE                                 ELSE command for 1st IF conditional statement
MG"ONLY INPUT 2 IS ACTIVE"         Message to be executed if 1st IF conditional statement is false
ENDIF                               End of 1st conditional statement
#WAIT                                Label to be used for a loop
JP#WAIT, (@IN[1]=0) | (@IN[2]=0)   Loop until both input 1 and input 2 are not active
RI0                                 End Input Interrupt Routine without restoring trippoints

```

Subroutines

A subroutine is a group of instructions beginning with a label and ending with an end command (EN). Subroutines are called from the main program with the jump subroutine instruction JS, followed by a label or line number, and conditional statement. Up to 8 subroutines can be nested. After the subroutine is executed, the program sequencer returns to the program location where the subroutine was called unless the subroutine stack is manipulated as described in the following section.

Example:

An example of a subroutine to draw a square 500 counts per side is given below. The square is drawn at vector position 1000,1000.

```

#M          Begin Main Program
CB1        Clear Output Bit 1 (pick up pen)
VP 1000,1000;LE;BGS  Define vector position; move pen
AMS        Wait for after motion trippoint
SB1        Set Output Bit 1 (put down pen)
JS #Square;CB1      Jump to square subroutine
EN         End Main Program
#Square    Square subroutine
V1=500;JS #L        Define length of side
V1=-V1;JS #L       Switch direction
EN         End subroutine
#L;PR V1,V1;BGX     Define X,Y; Begin X
AMX;BGY;AMY        After motion on X, Begin Y
EN         End subroutine

```

Stack Manipulation

It is possible to manipulate the subroutine stack by using the ZS command. Every time a JS instruction, interrupt or automatic routine (such as #POSERR or #LIMSWI) is executed, the subroutine stack is incremented by 1. Normally the stack is restored with an EN instruction. Occasionally it is desirable not to return back to the program line where the subroutine or interrupt was called. The ZS1 command clears 1 level of the stack. This allows the program sequencer to continue to the next line. The ZS0 command resets the stack to its initial value. For example, if a limit occurs and the #LIMSWI routine is executed, it is often desirable to restart the program sequence instead of returning to the location where the limit occurred. To do this, give a ZS command at the end of the #LIMSWI routine.

Auto-Start Routine

The DMC-40x0 has a special label for automatic program execution. A program which has been saved into the controller's non-volatile memory can be automatically executed upon power up or reset by beginning the program with the label #AUTO. The program must be saved into non-volatile memory using the command, BP.

Automatic Subroutines for Monitoring Conditions

Often it is desirable to monitor certain conditions continuously without tying up the host or DMC-40x0 program sequences. The controller can monitor several important conditions in the background. These conditions include checking for the occurrence of a limit switch, a defined input, position error, or a command error. Automatic monitoring is enabled by inserting a special, predefined label in the applications program. The pre-defined labels are:

SUBROUTINE	DESCRIPTION
#LIMSWI	Limit switch on any axis goes low
#ININT	Input specified by II goes low
#POSERR	Position error exceeds limit specified by ER
#MCTIME	Motion Complete timeout occurred. Timeout period set by TW command
#CMDERR	Bad command given
#AUTO	Automatically executes on power up

#AUTOERR	Automatically executes when a checksum is encountered during #AUTO start-up. Check error condition with _RS. bit 0 for variable checksum error bit 1 for parameter checksum error bit 2 for program checksum error bit 3 for master reset error (there should be no program)
----------	---

For example, the #POSERR subroutine will automatically be executed when any axis exceeds its position error limit. The commands in the #POSERR subroutine could decode which axis is in error and take the appropriate action. In another example, the #ININT label could be used to designate an input interrupt subroutine. When the specified input occurs, the program will be executed automatically.

NOTE: An application program must be running for #CMDERR to function.

Example - Limit Switch:

This program prints a message upon the occurrence of a limit switch. Note, for the #LIMSWI routine to function, the DMC-40x0 must be executing an applications program from memory. This can be a very simple program that does nothing but loop on a statement, such as #LOOP;JP #LOOP;EN. Motion commands, such as JG 5000 can still be sent from the PC even while the “dummy” applications program is being executed.

```

:ED                Edit Mode
000 #LOOP          Dummy Program
001 JP #LOOP;EN    Jump to Loop
002 #LIMSWI        Limit Switch Label
003 MG "LIMIT OCCURRED" Print Message
004 RE             Return to main program
<control> Q        Quit Edit Mode
:XQ #LOOP          Execute Dummy Program
:JG 5000           Jog
:BGX              Begin Motion

```

Now, when a forward limit switch occurs on the X axis, the #LIMSWI subroutine will be executed.

Notes regarding the #LIMSWI Routine:

- 1) The RE command is used to return from the #LIMSWI subroutine.
- 2) The #LIMSWI subroutine will be re-executed if the limit switch remains active.

The #LIMSWI routine is only executed when the motor is being commanded to move.

Example - Position Error

```

:ED                Edit Mode
000 #LOOP          Dummy Program
001 JP #LOOP;EN    Loop
002 #POSERR        Position Error Routine
003 V1=_TEX        Read Position Error
004 MG "EXCESS POSITION ERROR" Print Message
005 MG "ERROR=",V1= Print Error
006 RE             Return from Error
<control> Q        Quit Edit Mode
:XQ #LOOP          Execute Dummy Program
:JG 100000         Jog at High Speed
:BGX              Begin Motion

```

Example - Input Interrupt

#A	Label
II1	Input Interrupt on 1
JG 30000,,,60000	Jog
BGXW	Begin Motion
#LOOP;JP#LOOP;EN	Loop
#ININT	Input Interrupt
STXW;AM	Stop Motion
#TEST;JP #TEST, @IN[1]=0	Test for Input 1 still low
JG 30000,,,6000	Restore Velocities
BGXW	Begin motion
RI0	Return from interrupt routine to Main Program and do not re-enable trippoints

Example - Motion Complete Timeout

#BEGIN	Begin main program
TW 1000	Set the time out to 1000 ms
PA 10000	Position Absolute command
BGX	Begin motion
MCX	Motion Complete trip point
EN	End main program
#MCTIME	Motion Complete Subroutine
MG "X fell short"	Send out a message
EN	End subroutine

This simple program will issue the message "X fell short" if the X axis does not reach the commanded position within 1 second of the end of the profiled move.

Example - Command Error

#BEGIN	Begin main program
IN "ENTER SPEED", SPEED	Prompt for speed
JG SPEED;BGX;	Begin motion
JP #BEGIN	Repeat
EN	End main program
#CMDERR	Command error utility
JP#DONE,_ED<>2	Check if error on line 2
JP#DONE,_TC<>6	Check if out of range
MG "SPEED TOO HIGH"	Send message
MG "TRY AGAIN"	Send message
ZS1	Adjust stack
JP #BEGIN	Return to main program
#DONE	End program if other error
ZS0	Zero stack
EN	End program

The above program prompts the operator to enter a jog speed. If the operator enters a number out of range (greater than 8 million), the #CMDERR routine will be executed prompting the operator to enter a new number.

In multitasking applications, there is an alternate method for handling command errors from different threads. Using the XQ command along with the special operands described below allows the controller to either skip or retry invalid commands.

OPERAND	FUNCTION
_ED1	Returns the number of the thread that generated an error
_ED2	Retry failed command (operand contains the location of the failed command)
_ED3	Skip failed command (operand contains the location of the command after the failed command)

The operands are used with the XQ command in the following format:

```
XQ _ED2 (or _ED3), _ED1, 1
```

Where the “,1” at the end of the command line indicates a restart; therefore, the existing program stack will not be removed when the above format executes.

The following example shows an error correction routine which uses the operands.

Example - Command Error w/Multitasking

```
#A                               Begin thread 0 (continuous loop)
JP#A
EN                               End of thread 0

#B                               Begin thread 1
N=-1                             Create new variable
KP N                             Set KP to value of N, an invalid value
TY                               Issue invalid command
EN                               End of thread 1

#CMDERR                          Begin command error subroutine
IF _TC=6                         If error is out of range (KP -1)
N=1                              Set N to a valid number
XQ _ED2, _ED1, 1                 Retry KP N command
ENDIF
IF _TC=1                         If error is invalid command (TY)
XQ _ED3, _ED1, 1                 Skip invalid command
ENDIF
EN                               End of command error routine
```

Example - Communication Interrupt

A DMC-4010 is used to move the A axis back and forth from 0 to 10000. This motion can be paused, resumed and stopped via input from an auxiliary port terminal.

Instruction	Interpretation
#BEGIN	Label for beginning of program
CC 9600,0,1,0	Setup communication configuration for auxiliary serial port
CI 2	Setup communication interrupt for auxiliary serial port
MG {P2}"Type 0 to stop motion"	Message out of auxiliary port
MG {P2}"Type 1 to pause motion"	Message out of auxiliary port
MG {P2}"Type 2 to resume motion"	Message out of auxiliary port
rate=2000	Variable to remember speed
SPA=rate	Set speed of A axis motion
#LOOP	Label for Loop
PAA=10000	Move to absolute position 10000
BGA	Begin Motion on A axis

AMA	Wait for motion to be complete
PAA=0	Move to absolute position 0
BGA	Begin Motion on A axis
AMA	Wait for motion to be complete
JP #LOOP	Continually loop to make back and forth motion
EN	End main program
#COMINT	Interrupt Routine
JP #STOP,P2CH="0"	Check for S (stop motion)
JP #PAUSE,P2CH="1"	Check for P (pause motion)
JP #RESUME,P2CH="2"	Check for R (resume motion)
EN1,1	Do nothing
#STOP	Routine for stopping motion
STA;ZS;EN	Stop motion on A axis; Zero program stack; End Program
#PAUSE	Routine for pausing motion
rate=_SPA	Save current speed setting of A axis motion
SPA=0	Set speed of A axis to zero (allows for pause)
EN1,1	Re-enable trip-point and communication interrupt
#RESUME	Routine for resuming motion
SPA=rate	Set speed on A axis to original speed
EN1,1	Re-enable trip-point and communication interrupt

For additional information, see section on Using Communication Interrupt.

Example – Ethernet Communication Error

This simple program executes in the DMC-40x0 and indicates (via the serial port) when a communication handle fails. By monitoring the serial port, the user can re-establish communication if needed.

Instruction	Interpretation
#LOOP	Simple program loop
JP#LOOP	
EN	
#TCPEERR	Ethernet communication error auto routine
MG {P1}_IA4	Send message to serial port indicating which handle did not receive proper acknowledgment.
RE	

JS Subroutine Stack Variables (^a, ^b, ^c, ^d, ^e, ^f, ^g, ^h)

There are 8 variables that may be passed on the subroutine stack when using the JS command. Passing values on the stack is advanced DMC programming, and is recommended for experienced DMC programmers familiar with the concept of passing arguments by value and by reference.

Notes:

1. Passing parameters has no type checking, so it is important to exercise good programming style when passing parameters. See examples below for recommended syntax.
2. Do not use spaces in expressions containing ^.
3. Global variables MUST be assigned prior to any use in subroutines where variables are passed by reference.

Example: A Simple Adding Function

```
#Add
JS#SUM(1,2,3,4,5,6,7,8)           ;' call subroutine, pass values
MG _JS                             ;' print return value
EN
'

#SUM                               ;NO(^a,^b,^c,^d,^e,^f,^g,^h) syntax note for use
EN,, (^a+^b+^c+^d+^e+^f+^g+^h)    ;' return sum

:Executed program from program1.dmc
36.0000
```

Example: Variable, and an Important Note about Creating Global Variables

```
#Var
value=5                             ;'a value to be passed by reference
global=8                             ;'a global variable
JS#SUM(&value,1,2,3,4,5,6,7)        ;'note first arg passed by reference
MG value                             ;'message out value after subroutine.
MG _JS                               ;'message out returned value
EN
'

#SUM                               ;NO(* ^a,^b,^c,^d,^e,^f,^g)
^a=^b+^c+^d+^e+^f+^g+^h+global
EN,, ^a
'notes:
'do not use spaces when working with ^
'If using global variables, they MUST be created before the subroutine is run

Executed program from program2.dmc
36.0000
36.0000
```

Example: Working with Arrays

```
#Array
DM speeds[8]
DM other[256]
JS#zeroAry("speeds",0)             ;'zero out all buckets in speeds[]
JS#zeroAry("other",0)             ;'zero out all buckers in other[]
EN
'

#zeroAry                           ;NO(array ^a, ^b) zeros array starting at index ^b
^a[^b]=0
^b=^b+1
JP#zeroAry, (^b<^a[-1])           ;'[-1] returns the length of an array
EN
```

Example: Abstracting Axes

```
#Axes
JS#runMove(0,10000,1000,100000,100000)
MG "Position:",_JS
EN
'

#runMove                           ;NO(axis ^a, PR ^b, SP ^c, AC ^d, DC ^e) Profile movement for axis
```

```

~a=^a                ;'~a is global, so use carefully in subroutines
                    'try one variable axis a-h for each thread A-H

PR~a=^b
SP~a=^c
AC~a=^d
DC~a=^e
BG~a
MC~a
EN,,_TP~a

```

Example: Local Scope

```

#Local
JS#POWER(2,2)
MG_JS
JS#POWER(2,16)
MG_JS
JS#POWER(2,-8)
MG_JS
'
#POWER                ;NO(base ^a,exponent^b) Returns base^exponent power. +/- integer only
^c=1                  ;'unpassed variable space (^c-^h) can be used as local scope variables
IF ^b=0                ;'special case, exponent = 0
    EN,,1
ENDIF
IF ^b<0                ;'special case, exponent < 0, invert result
    ^d=1
    ^b=@ABS[^b]
ELSE
    ^d=0
ENDIF
#PWRHLPR
^c=^c*^a
^b=^b-1
JP#PWRHLPR,^b>0
IF ^d=1                ;'if inversion required
    ^c=(1/^c)
ENDIF
EN,,^c

```

```

Executed program from program1.dmc
4.0000
65536.0000
0.0039

```

Example: Recursion

```

'although the stack depth is only 16, Galil DMC code does support recursion
JS#AxisInfo(0)
MG{Z2.0}"Recursed through ",_JS," stacks"
EN
'
#AxisInfo                ;NO(axis ^a) List info for axes
~h=^a
^b=(^a+$41)*$1000000    ;'convert to Galil String

```

```

MG^b{S1}, " Axis: "{N}
MG{F8.0}"Position: ",_TP~h," Error:",_TE~h," Torque:",_TT~h{F1.4}
IF ^a=7                                ;'recursion exit condition
EN,,1
ENDIF
JS#AxsInfo(^a + 1)                      ;'stack up recursion
EN,,_JS+1                               ;' as recursion closes, add up stack depths

Executed program from program1.dmc
A Axis: Position: 00029319 Error: 00001312 Torque: 9.9982
B Axis: Position: -00001612 Error: 00000936 Torque: 1.7253
C Axis: Position: 00001696 Error:-00001076 Torque:-1.9834
D Axis: Position: -00002020 Error: 00001156 Torque: 2.1309
E Axis: Position: 00000700 Error:-00001300 Torque:-2.3963
F Axis: Position: 00000156 Error:-00000792 Torque:-1.4599
G Axis: Position: -00002212 Error: 00001732 Torque: 3.1926
H Axis: Position: 00002665 Error:-00001721 Torque:-3.1723
Recursed through 8 stacks

```

General Program Flow and Timing information

This section will discuss general programming flow and timing information for Galil programming.

REM vs. NO or ' comments

There are 2 ways to add comments to a .dmc program. REM statements or NO/' comments. The main difference between the 2 is that REM statements are stripped from the program upon download to the controller and NO or ' comments are left in the program. In most instances the reason for using REM statements instead of NO or ' is to save program memory. The other benefit to using REM commands comes when command execution of a loop, thread or any section of code is critical. Although they do not take much time, NO and ' comments still take time to process. So when command execution time is critical, REM statements should be used. The 2 examples below demonstrate the difference in command execution of a loop containing comments.

Note: Actual processing time will vary dependent upon number of axes, communication activity, number of threads currently executing etc.

```

#a
i=0;'initialize a counter
t= TIME;' set an initial time reference
#loop
NO this comment takes time to process
'this comment takes time to process
i=i+1;'this comment takes time to process
JP#loop,i<1000
MG TIME-t;'display number of samples from initial time reference
EN

```

When executed on a DMC-4020, the output from the above program returned a 116, which indicates that it took 116 samples (TM 1000) to process the commands from 't=TIME' to 'MG TIME-t'. This is about 114ms +/-2ms.

Now when the comments inside of the #loop routine are changed into REM statements (a REM statement must always start on a new line), the processing is greatly reduced.

When executed on the same DMC-4020, the output from the program shown below returned a 62, which indicates that it took 62 samples to process the commands from 't=TIME' to 'MG TIME-t'. This is about 60ms +/-2ms, and about 50% faster than when the comments were downloaded to the controller.

```

#a
i=0;'initialize a counter
t= TIME;' set an initial time reference
#loop
REM this comment is removed upon download and takes no time to process
REM this comment is removed upon download and takes no time to process
i=i+1
REM this comment is removed upon download and takes no time to process
JP#loop,i<1000
MG TIME-t;'display number of samples from initial time reference
EN

```

WT vs AT and coding deterministic loops

The main difference between WT and AT is that WT will hold up execution of the next command for the specified time from the execution of the WT command, AT will hold up execution of the next command for the specified time from the last time reference set with the AT command.

```

#A
AT0;'set initial AT time reference
WT 1000,1;'wait 1000 samples
t1=TIME
AT 4000,1;'wait 4000 samples from last time reference
t2=TIME-t1
REM in the above scenario, t2 will be ~3000 because AT 4000,1 will have
REM paused program execution from the time reference of AT0
REM since the WT 1000,1 took 1000 samples, there was only 3000 samples left
REM of the "4000" samples for AT 4000,1
MG t,t2;'this should output 1000,3000
EN;'End program

```

Where the functionality of the operation of the AT command is very useful is when it is required to have a deterministic loop operating on the controller. These instances range from writing PLC-type scan threads to writing custom control algorithms. The key to having a deterministic loop time is to have a trippoint that will wait a specified time independent of the time it took to execute the loop code. In this definition, the AT command is a perfect fit. The below code is an example of a PLC-type scan thread that runs at a 500ms loop rate. A typical implementation would be to run this code in a separate thread (ex XQ#plcscan,2).

```

REM this code will set output 3 high if
REM inputs 1 and 2 are high, and input 3 is low
REM else output 3 will be low
REM if input 4 is low, output 1 will be high
REM and ouput 3 will be low regardless of the
REM states of inputs 1,2 or 3
#plcscan
AT0;'set initial time reference
#scan
REM mask inputs 1-4
ti=_TI0&$F
REM variables for bit 1 and bit 3
b1=0;b3=0
REM if input 4 is high set bit 1 and clear bit 3
REM ti&8 - gets 4th bit, if 4th bit is high result = 8

```



```

IF ti&8=8;b1=1;ELSE
REM ti&7 get lower 3 bits, if 011 then result = 3
IF ti&7=3;b3=1;ENDIF;ENDIF
REM set output bits 1 and 3 accordingly
REM set outputs at the end for a PLC scan
OB1,b1;OB3,b3
REM wait 500ms (for 500 samples use AT-500,1)
REM the '-' will reset the time reference
AT-500
JP#scan

```

Mathematical and Functional Expressions

Mathematical Operators

For manipulation of data, the DMC-40x0 provides the use of the following mathematical operators:

Operator	Function
+	Addition
-	Subtraction
*	Multiplication
/	Division
%	Modulus
&	Logical And (Bit-wise)
	Logical Or (On some computers, a solid vertical line appears as a broken line)
()	Parenthesis

The numeric range for addition, subtraction and multiplication operations is +/-2,147,483,647.9999. The precision for division is 1/65,000.

Mathematical operations are executed from left to right. Calculations within parentheses have precedence.

Examples:

speed = 7.5*V1/2	The variable, speed, is equal to 7.5 multiplied by V1 and divided by 2
count = count+2	The variable, count, is equal to the current value plus 2.
result = _TPX-(@COS[45]*40)	Puts the position of X - 28.28 in result. 40 * cosine of 45° is 28.28
temp = @IN[1]&@IN[2]	temp is equal to 1 only if Input 1 and Input 2 are high

Bit-Wise Operators

The mathematical operators & and | are bit-wise operators. The operator, &, is a Logical And. The operator, |, is a Logical Or. These operators allow for bit-wise operations on any valid DMC-40x0 numeric operand, including variables, array elements, numeric values, functions, keywords, and arithmetic expressions. The bit-wise operators may also be used with strings. This is useful for separating characters from an input string. When using the input command for string input, the input variable will hold up to 6 characters. These characters are combined into a single value which is represented as 32 bits of integer and 16 bits of fraction. Each ASCII character is represented as one byte (8 bits), therefore the input variable can hold up to six characters. The first character of the string will be placed in the top byte of the variable and the last character will be placed in the lowest significant byte of the fraction. The characters can be individually separated by using bit-wise operations as illustrated in the following example:

```

#TEST                                Begin main program

```

```

IN "ENTER",len{S6}           Input character string of up to 6 characters into variable 'len'
Flen=@FRAC[len]             Define variable 'Flen' as fractional part of variable 'len'
Flen=$10000*Flen             Shift Flen by 32 bits (IE - convert fraction, Flen, to integer)
len1=(Flen&$00FF)           Mask top byte of Flen and set this value to variable 'len1'
len2=(Flen&$FF00)/$100      Let variable, 'len2' = top byte of Flen
len3=len&$000000FF          Let variable, 'len3' = bottom byte of len
len4=(len&$0000FF00)/$100   Let variable, 'len4' = second byte of len
len5=(len&$00FF0000)/$10000 Let variable, 'len5' = third byte of len
len6=(len&$FF000000)/$1000000 Let variable, 'len6' = fourth byte of len
MG len6 {S4}                 Display 'len6' as string message of up to 4 chars
MG len5 {S4}                 Display 'len5' as string message of up to 4 chars
MG len4 {S4}                 Display 'len4' as string message of up to 4 chars
MG len3 {S4}                 Display 'len3' as string message of up to 4 chars
MG len2 {S4}                 Display 'len2' as string message of up to 4 chars
MG len1 {S4}                 Display 'len1' as string message of up to 4 chars
EN

```

This program will accept a string input of up to 6 characters, parse each character, and then display each character. Notice also that the values used for masking are represented in hexadecimal (as denoted by the preceding '\$'). For more information, see section Sending Messages.

To illustrate further, if the user types in the string "TESTME" at the input prompt, the controller will respond with the following:

```

T                               Response from command MG len6 {S4}
E                               Response from command MG len5 {S4}
S                               Response from command MG len4 {S4}
T                               Response from command MG len3 {S4}
M                               Response from command MG len2 {S4}
E                               Response from command MG len1 {S4}

```

Functions

FUNCTION	DESCRIPTION
@SIN[n]	Sine of n (n in degrees, with range of -32768 to 32767 and 16-bit fractional resolution)
@COS[n]	Cosine of n (n in degrees, with range of -32768 to 32767 and 16-bit fractional resolution)
@TAN[n]	Tangent of n (n in degrees, with range of -32768 to 32767 and 16-bit fractional resolution)
@ASIN*[n]	Arc Sine of n, between -90° and +90°. Angle resolution in 1/64000 degrees.
@ACOS*[n]	Arc Cosine of n, between 0 and 180°. Angle resolution in 1/64000 degrees.
@ATAN*[n]	Arc Tangent of n, between -90° and +90°. Angle resolution in 1/64000 degrees
@COM[n]	1's Complement of n
@ABS[n]	Absolute value of n
@FRAC[n]	Fraction portion of n
@INT[n]	Integer portion of n
@RND[n]	Round of n (Rounds up if the fractional part of n is .5 or greater)
@SQR[n]	Square root of n (Accuracy is +/- .004)
@IN[n]	Return digital input at general input n (where n starts at 1)
@OUT[n]	Return digital output at general output n (where n starts at 1)

@AN[n]	Return analog input at general analog in n (where n starts at 1)
--------	--

*Note that these functions are multi-valued. An application program may be used to find the correct band.

Functions may be combined with mathematical expressions. The order of execution of mathematical expressions is from left to right and can be over-ridden by using parentheses.

Examples:

```
v1=@ABS[V7]      The variable, v1, is equal to the absolute value of variable v7.
v2=5*@SIN[pos]  The variable, v2, is equal to five times the sine of the variable, pos.
v3=@IN[1]       The variable, v3, is equal to the digital value of input 1.
v4=2*(5+@AN[5]) The variable, v4, is equal to the value of analog input 5 plus 5, then
                multiplied by 2.
```

Variables

For applications that require a parameter that is variable, the DMC-40x0 provides 510 variables. These variables can be numbers or strings. A program can be written in which certain parameters, such as position or speed, are defined as variables. The variables can later be assigned by the operator or determined by program calculations. For example, a cut-to-length application may require that a cut length be variable.

Example:

```
posx=5000        Assigns the value of 5000 to the variable posx
PR posx          Assigns variable posx to PR command
JG rpmY*70       Assigns variable rpmY multiplied by 70 to JG command.
```

Programmable Variables

The DMC-40x0 allows the user to create up to 510 variables. Each variable is defined by a name which can be up to eight characters. The name must start with an alphabetic character; however, numbers are permitted in the rest of the name. Spaces are not permitted. Variable names should not be the same as DMC-40x0 instructions. For example, PR is not a good choice for a variable name.

Note: It is generally a good idea to use lower-case variable names so there is no confusion between Galil commands and variable names.

Examples of valid and invalid variable names are:

Valid Variable Names

```
posx
pos1
speedz
```

Invalid Variable Names

```
RealLongName    ; 'Cannot have more than 8 characters
123              ; 'Cannot begin variable name with a number
speed z         ; 'Cannot have spaces in the name
```

Assigning Values to Variables:

Assigned values can be numbers, internal variables and keywords, functions, controller parameters and strings. The range for numeric variable values is 4 bytes of integer (231) followed by two bytes of fraction (+/- 2,147,483,647.9999).

Numeric values can be assigned to programmable variables using the equal sign.

Any valid DMC-40x0 function can be used to assign a value to a variable. For example, v1=@ABS[v2] or v2=@IN[1]. Arithmetic operations are also permitted.

To assign a string value, the string must be in quotations. String variables can contain up to six characters which must be in quotation.

Examples:

posX=_TPX	Assigns returned value from TPX command to variable posX.
speed=5.75	Assigns value 5.75 to variable speed
input=@IN[2]	Assigns logical value of input 2 to variable input
v2=v1+v3*v4	Assigns the value of v1 plus v3 times v4 to the variable v2.
var="CAT"	Assign the string, CAT, to var
MG var{S3}	Displays the variable var - (CAT)

Assigning Variable Values to Controller Parameters

Variable values may be assigned to controller parameters such as GN or PR.

PR v1	Assign v1 to PR command
SP vS*2000	Assign vS*2000 to SP command

Displaying the value of variables at the terminal

Variables may be sent to the screen using the format, variable=. For example, v1= , returns the value of the variable v1.

Example - Using Variables for Joystick

The example below reads the voltage of an X-Y joystick and assigns it to variables vX and vY to drive the motors at proportional velocities, where:

$$10 \text{ Volts} = 3000 \text{ rpm} = 200000 \text{ c/sec}$$

$$\text{Speed/Analog input} = 200000/10 = 20000$$

#JOYSTIK	Label
JG 0,0	Set in Jog mode
BGXY	Begin Motion
AT0	Set AT time reference
#LOOP	Loop
vX=@AN[1]*20000	Read joystick X
vY=@AN[2]*20000	Read joystick Y
JG vX,vY	Jog at variable vX,vY
AT-4	Wait 4ms from last time reference, creates a deterministic loop time
JP#LOOP	Repeat
EN	End

Operands

Operands allow motion or status parameters of the DMC-40x0 to be incorporated into programmable variables and expressions. Most DMC commands have an equivalent operand - which are designated by adding an underscore (_) prior to the DMC-40x0 command. The command reference indicates which commands have an associated operand.

Status commands such as Tell Position return actual values, whereas action commands such as KP or SP return the values in the DMC-40x0 registers. The axis designation is required following the command.

Examples of Internal Variables:

POSX=_TPX	Assigns value from Tell Position X to the variable POSX.
GAIN=_GNZ*2	Assigns value from GNZ multiplied by two to variable, GAIN.
JP #LOOP,_TEX>5	Jump to #LOOP if the position error of X is greater than 5

JP #ERROR, _TC=1 Jump to #ERROR if the error code equals 1.

Operands can be used in an expression and assigned to a programmable variable, but they cannot be assigned a value. For example: _GNX=2 is invalid.

Special Operands (Keywords)

The DMC-40x0 provides a few additional operands which give access to internal variables that are not accessible by standard DMC-40x0 commands.

Keyword	Function
_BGn	*Returns a 1 if motion on axis 'n' is complete, otherwise returns 0.
_BN	*Returns serial # of the board.
_DA	*Returns the number of arrays available
_DL	*Returns the number of available labels for programming
_DM	*Returns the available array memory
_HMn	*Returns status of Home Switch (equals 0 or 1)
_LFn	Returns status of Forward Limit switch input of axis 'n' (equals 0 or 1)
_LRX	Returns status of Reverse Limit switch input of axis 'n' (equals 0 or 1)
_UL	*Returns the number of available variables
TIME	Free-Running Real Time Clock (off by 2.4% - Resets with power-on). Note: TIME does not use an underscore character (_) as other keywords.

* - These keywords have corresponding commands while the keywords _LF, _LR, and TIME do not have any associated commands. All keywords are listed in the Command Reference.

Examples of Keywords:

```
V1=_LFX            Assign V1 the logical state of the Forward Limit Switch on the X-axis
V3=TIME           Assign V3 the current value of the time clock
V4=_HMW           Assign V4 the logical state of the Home input on the W-axis
```

Arrays

For storing and collecting numerical data, the DMC-40x0 provides array space for 16000 elements. The arrays are one dimensional and up to 30 different arrays may be defined. Each array element has a numeric range of 4 bytes of integer (2^{31}) followed by two bytes of fraction (+/-2,147,483,647.9999).

Arrays can be used to capture real-time data, such as position, torque and analog input values. In the contouring mode, arrays are convenient for holding the points of a position trajectory in a record and playback application.

Defining Arrays

An array is defined with the command DM. The user must specify a name and the number of entries to be held in the array. An array name can contain up to eight characters, starting with an uppercase alphabetic character. The number of entries in the defined array is enclosed in [].

Example:

```
DM posx[7]                      Defines an array names 'posx' with seven entries
DM speed[100]                   Defines an array named speed with 100 entries
DA posx[]                        Frees array space
```

Assignment of Array Entries

Like variables, each array element can be assigned a value. Assigned values can be numbers or returned values from instructions, functions and keywords.

Array elements are addressed starting at count 0. For example the first element in the 'posx' array (defined with the DM command, DM posx[7]) would be specified as posx[0].

Values are assigned to array entries using the equal sign. Assignments are made one element at a time by specifying the element number with the associated array name.

NOTE: Arrays must be defined using the command, DM, before assigning entry values.

Examples:

DM speed[10]	Dimension speed Array
speed[1]=7650.2	Assigns the first element of the array, 'speed' the value 7650.2
speed[1]=	Returns array element value
posx[10]=_TPX	Assigns the 10 th element of the array 'posx' the returned value from the tell position command.
con[2]=@COS[pos]*2	Assigns the second element of the array 'con' the cosine of the variable POS multiplied by 2.
timer[1]=TIME	Assigns the first element of the array timer the returned value of the TIME keyword.

Using a Variable to Address Array Elements

An array element number can also be a variable. This allows array entries to be assigned sequentially using a counter.

Example:

#A	Begin Program
count=0;DM pos[10]	Initialize counter and define array
#LOOP	Begin loop
WT 10	Wait 10 msec
pos[count]=_TPX	Record position into array element
pos[count]=	Report position
count=count+1	Increment counter
JP #LOOP, count<10	Loop until 10 elements have been stored
EN	End Program

The above example records 10 position values at a rate of one value per 10 msec. The values are stored in an array named POS. The variable, COUNT, is used to increment the array element counter. The above example can also be executed with the automatic data capture feature described below.

Uploading and Downloading Arrays to On Board Memory

Arrays may be uploaded and downloaded using the QU and QD commands.

QU array[,start,end,delim

QD array[,start,end

where array is an array name such as A[].

start is the first element of array (default=0)

end is the last element of array (default=last element)

delim specifies whether the array data is separated by a comma (delim=1) or a carriage return (delim=0).

The file is terminated using <control>Z, <control>Q, <control>D or \.

Automatic Data Capture into Arrays

The DMC-40x0 provides a special feature for automatic capture of data such as position, position error, inputs or torque. This is useful for teaching motion trajectories or observing system performance. Up to eight types of data can be captured and stored in eight arrays. The capture rate or time interval may be specified. Recording can be done as a one time event or as a circular continuous recording.

Command Summary - Automatic Data Capture

Command	Description
RA n[],m[],o[],p[]	Selects up to eight arrays for data capture. The arrays must be defined with the DM command.
RD type1,type2,type3,type4	Selects the type of data to be recorded, where type1, type2, type3, and type 4 represent the various types of data (see table below). The order of data type is important and corresponds with the order of n,m,o,p arrays in the RA command.
RC n,m	The RC command begins data collection. Sets data capture time interval where n is an integer between 1 and 8 and designates 2 ⁿ msec between data. m is optional and specifies the number of elements to be captured. If m is not defined, the number of elements defaults to the smallest array defined by DM. When m is a negative number, the recording is done continuously in a circular manner. _RD is the recording pointer and indicates the address of the next array element. n=0 stops recording.
RC?	Returns a 0 or 1 where, 0 denotes not recording, 1 specifies recording in progress

Data Types for Recording:

Data type	Description
TIME	Controller time as reported by the TIME command
_AFn	Analog input (n=X,Y,Z,W,E,F,G,H, for AN inputs 1-8)
_DEX	2 nd encoder position (dual encoder)
_NOX	Status bits
_OP	Output
_RLX	Latched position
_RPX	Commanded position
_SCX	Stop code
_TEX	Position error
_TI	Inputs
_TPX	Encoder position
_TSX	Switches (only bit 0-4 valid)
_TTX	Torque (reports digital value +/-32544)

Note: X may be replaced by Y,Z or W for capturing data on other axes.

Operand Summary - Automatic Data Capture

_RC	Returns a 0 or 1 where, 0 denotes not recording, 1 specifies recording in progress
_RD	Returns address of next array element.

Example - Recording into An Array

During a position move, store the X and Y positions and position error every 2 msec.

#RECORD	Begin program
DM XPOS[300],YPOS[300]	Define X,Y position arrays
DM XERR[300],YERR[300]	Define X,Y error arrays
RA XPOS[],XERR[],YPOS[],YERR[]	Select arrays for capture
RD _TPX,_TEX,_TPY,_TEY	Select data types
PR 10000,20000	Specify move distance
RC1	Start recording now, at rate of 2 msec
BG XY	Begin motion
#A;JP #A,_RC=1	Loop until done
MG "DONE"	Print message
EN	End program
#PLAY	Play back
N=0	Initial Counter
JP# DONE,N>300	Exit if done
N=	Print Counter
X POS[N]=	Print X position
Y POS[N]=	Print Y position
XERR[N]=	Print X error
YERR[N]=	Print Y error
N=N+1	Increment Counter
#DONE	Done
EN	End Program

De-allocating Array Space

Array space may be de-allocated using the DA command followed by the array name. DA*[0] deallocates all the arrays.

Input of Data (Numeric and String)

Input of Data

The command, IN, is used to prompt the user to input numeric or string data. Using the IN command, the user may specify a message prompt by placing a message in quotations. When the controller executes an IN command, the controller will wait for the input of data. The input data is assigned to the specified variable or array element.

An Example for Inputting Numeric Data

```
#A
IN "Enter Length", lenX
EN
```

In this example, the message "Enter Length" is displayed on the computer screen. The controller waits for the operator to enter a value. The operator enters the numeric value which is assigned to the variable, lenX.

Cut-to-Length Example

In this example, a length of material is to be advanced a specified distance. When the motion is complete, a cutting head is activated to cut the material. The length is variable, and the operator is prompted to input it in inches. Motion starts with a start button which is connected to input 1.

The load is coupled with a 2 pitch lead screw. A 2000 count/rev encoder is on the motor, resulting in a resolution of 4000 counts/inch. The program below uses the variable len, to length. The IN command is used to prompt the operator to enter the length, and the entered value is assigned to the variable len.

#BEGIN	LABEL
AC 800000	Acceleration
DC 800000	Deceleration
SP 5000	Speed
len=3.4	Initial length in inches
#CUT	Cut routine
AI1	Wait for start signal
IN "enter Length(IN)", len	Prompt operator for length in inches
PR len *4000	Specify position in counts
BGX	Begin motion to move material
AMX	Wait for motion done
SB1	Set output to cut
WT100;CB1	Wait 100 msec, then turn off cutter
JP #CUT	Repeat process
EN	End program

Operator Data Entry Mode

The Operator Data Entry Mode provides for un-buffered data entry through the auxiliary RS-232 port. In this mode, the DMC-40x0 provides a buffer for receiving characters. This mode may only be used when executing an applications program.

The Operator Data Entry Mode may be specified for Port 2 only. This mode may be exited with the \ or <escape> key.

NOTE: Operator Data Entry Mode cannot be used for high rate data transfer.

Set the third field of the CC command to one to set the Operator Data Entry Mode.

To capture and decode characters in the Operator Data Mode, the DMC-40x0 provides special the following keywords:

Keyword	Function
P2CH	Contains the last character received
P2ST	Contains the received string
P2NM	Contains the received number
P2CD	Contains the status code: -1 mode disabled 0 nothing received 1 received character, but not <enter> 2 received string, not a number 3 received number

NOTE: The value of P2CD returns to zero after the corresponding string or number is read.

These keywords may be used in an applications program to decode data and they may also be used in conditional statements with logical operators.

Example

Instruction	Interpretation
JP #LOOP,P2CD< >3	Checks to see if status code is 3 (number received)
JP #P,P1CH="V"	Checks if last character received was a V
PR P2NM	Assigns received number to position

```
JS #XAXIS,P1ST="X"
```

```
Checks to see if received string is X
```

Using Communication Interrupt

The DMC-40x0 provides a special interrupt for communication allowing the application program to be interrupted by input from the user. The interrupt is enabled using the CI command. The syntax for the command is CI n:

n = 0	Don't interrupt Port 2
n = 1	Interrupt on <enter> Port 2
n = 2	Interrupt on any character Port 2
n = -1	Clear any characters in buffer

The #COMINT label is used for the communication interrupt. For example, the DMC-40x0 can be configured to interrupt on any character received on Port 2. The #COMINT subroutine is entered when a character is received and the subroutine can decode the characters. At the end of the routine the EN command is used. EN,1 will re-enable the interrupt and return to the line of the program where the interrupt was called, EN will just return to the line of the program where it was called without re-enabling the interrupt. As with any automatic subroutine, a program must be running in thread 0 at all times for it to be enabled.

Example

A DMC-40x0 is used to jog the A and B axis. This program automatically begins upon power-up and allows the user to input values from the main serial port terminal. The speed of either axis may be changed during motion by specifying the axis letter followed by the new speed value. An S stops motion on both axes.

Instruction	Interpretation
#AUTO	Label for Auto Execute
speedA=10000	Initial A speed
speedB=10000	Initial B speed
CI 2	Set Port 2 for Character Interrupt
JG speedA, speedB	Specify jog mode speed for A and B axis
BGXY	Begin motion
#PRINT	Routine to print message to terminal
MG{P2}"TO CHANGE SPEEDS"	Print message
MG{P2}"TYPE A OR B"	
MG{P2}"TYPE S TO STOP"	
#JOGLOOP	Loop to change Jog speeds
JG speedA, speedB	Set new jog speed
JP #JOGLOOP	
EN	End of main program
#COMINT	Interrupt routine
JP #A,P2CH="A"	Check for A
JP #B,P2CH="B"	Check for B
JP #C,P2CH="S"	Check for S
ZS1;CI2;JP#JOGLOOP	Jump if not X,Y,S
#A;JS#NUM	
speedX=val	New X speed
ZS1;CI2;JP#PRINT	Jump to Print
#B;JS#NUM	
speedY=val	New Y speed
ZS1;CI2;JP#PRINT	Jump to Print
#C;ST;AMX;CI-1	Stop motion on S
MG{^8}, "THE END"	
ZS;EN,1	End-Re-enable interrupt

```

#NUM                               Routine for entering new jog speed
MG "ENTER",P2CH{S},"AXIS          Prompt for value
SPEED" {N}
#NUMLOOP; CI-1                     Check for enter
#NMLP                               Routine to check input from terminal
JP #NMLP,P2CD<2                   Jump to error if string
JP #ERROR,P2CD=2                   Read value
val=P2NM
EN                                  End subroutine
#ERROR;CI-1                         Error Routine
MG "INVALID-TRY AGAIN"            Error message
JP #NMLP
EN                                  End

```

Inputting String Variables

String variables with up to six characters may be input using the specifier, {Sn} where n represents the number of string characters to be input. If n is not specified, six characters will be accepted. For example, IN "Enter A,B or C", V{S} specifies a string variable to be input.

The DMC-40x0, stores all variables as 6 bytes of information. When a variable is specified as a number, the value of the variable is represented as 4 bytes of integer and 2 bytes of fraction. When a variable is specified as a string, the variable can hold up to 6 characters (each ASCII character is 1 byte). When using the IN command for string input, the first input character will be placed in the top byte of the variable and the last character will be placed in the lowest significant byte of the fraction. The characters can be individually separated by using bit-wise operations, see section Bit-wise Operators.

Output of Data (Numeric and String)

Numerical and string data can be output from the controller using several methods. The message command, MG, can output string and numerical data. Also, the controller can be commanded to return the values of variables and arrays, as well as other information using the interrogation commands (the interrogation commands are described in chapter 5).

Sending Messages

Messages may be sent to the bus using the message command, MG. This command sends specified text and numerical or string data from variables or arrays to the screen.

Text strings are specified in quotes and variable or array data is designated by the name of the variable or array. For example:

```
MG "The Final Value is", result
```

In addition to variables, functions and commands, responses can be used in the message command. For example:

```
MG "Analog input is", @AN[1]
MG "The Position of A is", _TPA
```

Specifying the Port for Messages:

The port can be specified with the specifier, {P1} for the main serial port {P2} for auxiliary serial port, or {En} for the Ethernet port.

```
MG {P2} "Hello World"           Sends message to Auxiliary Port
```

Formatting Messages

String variables can be formatted using the specifier, {Sn} where n is the number of characters, 1 thru 6. For example:

```
MG STR {S3}
```

This statement returns 3 characters of the string variable named STR.

Numeric data may be formatted using the {Fn.m} expression following the completed MG statement. {Fn.m} formats data in HEX instead of decimal. The actual numerical value will be formatted with n characters to the left of the decimal and m characters to the right of the decimal. Leading zeros will be used to display specified format.

For example:

```
MG "The Final Value is", result {F5.2}
```

If the value of the variable result is equal to 4.1, this statement returns the following:

```
The Final Value is 00004.10
```

If the value of the variable result is equal to 999999.999, the above message statement returns the following:

```
The Final Value is 99999.99
```

The message command normally sends a carriage return and line feed following the statement. The carriage return and the line feed may be suppressed by sending {N} at the end of the statement. This is useful when a text string needs to surround a numeric value.

Example:

```
#A
JG 50000;BGA;ASA
MG "The Speed is", _TVA {F5.1} {N}
MG "counts/sec"
EN
```

When #A is executed, the above example will appear on the screen as:

```
The speed is 50000 counts/sec
```

Using the MG Command to Configure Terminals

The MG command can be used to configure a terminal. Any ASCII character can be sent by using the format {^n} where n is any integer between 1 and 255.

Example:

```
MG {^07} {^255}
```

sends the ASCII characters represented by 7 and 255 to the bus.

Summary of Message Functions

function	description
" "	Surrounds text string
{Fn.m}	Formats numeric values in decimal n digits to the left of the decimal point and m digits to the right
{P1}, {P2} or {E}	Send message to Main Serial Port, Auxiliary Serial Port or Ethernet Port
{Sn.m}	Formats numeric values in hexadecimal
{^n}	Sends ASCII character specified by integer n
{N}	Suppresses carriage return/line feed
{Sn}	Sends the first n characters of a string variable, where n is 1 thru 6.

Displaying Variables and Arrays

Variables and arrays may be sent to the screen using the format, `variable=` or `array[x]=`. For example, `v1=` returns the value of `v1`.

Example - Printing a Variable and an Array element

Instruction	Interpretation
<code>#DISPLAY</code>	Label
<code>DM posA[7]</code>	Define Array POSA with 7 entries
<code>PR 1000</code>	Position Command
<code>BGX</code>	Begin
<code>AMX</code>	After Motion
<code>v1=_TPA</code>	Assign Variable v1
<code>posA[1]=_TPA</code>	Assign the first entry
<code>v1=</code>	Print v1

Interrogation Commands

The DMC-40x0 has a set of commands that directly interrogate the controller. When these command are entered, the requested data is returned in decimal format on the next line followed by a carriage return and line feed. The format of the returned data can be changed using the Position Format (PF), and Leading Zeros (LZ) command. For a complete description of interrogation commands, see [Chapter 5](#).

Using the PF Command to Format Response from Interrogation Commands

The command, PF, can change format of the values returned by theses interrogation commands:

<code>BL ?</code>	<code>LE ?</code>
<code>DE ?</code>	<code>PA ?</code>
<code>DP ?</code>	<code>PR ?</code>
<code>EM ?</code>	<code>TN ?</code>
<code>FL ?</code>	<code>VE ?</code>
<code>IP ?</code>	<code>TE</code>
<code>TP</code>	

The numeric values may be formatted in decimal or hexadecimal with a specified number of digits to the right and left of the decimal point using the PF command.

Position Format is specified by:

`PF m.n`

where `m` is the number of digits to the left of the decimal point (0 thru 10) and `n` is the number of digits to the right of the decimal point (0 thru 4) A negative sign for `m` specifies hexadecimal format.

Hex values are returned preceded by a \$ and in 2's complement. Hex values should be input as signed 2's complement, where negative numbers have a negative sign. The default format is `PF 10.0`.

If the number of decimal places specified by PF is less than the actual value, a nine appears in all the decimal places.

Example

Instruction	Interpretation
<code>:DP21</code>	Define position
<code>:TPA</code>	Tell position
<code>0000000021</code>	Default format
<code>:PF4</code>	Change format to 4 places

:TPA	Tell position
0021	New format
:PF-4	Change to hexadecimal format
:TPA	Tell Position
\$0015	Hexadecimal value
:PF2	Format 2 places
:TPA	Tell Position
99	Returns 99 if position greater than 99

Removing Leading Zeros from Response to Interrogation Commands

The leading zeros on data returned as a response to interrogation commands can be removed by the use of the command, LZ.

LZ0	Disables the LZ function
TP	Tell Position Interrogation Command
-0000000009, 0000000005	Response (With Leading Zeros)
LZ1	Enables the LZ function
TP	Tell Position Interrogation Command
-9, 5	Response (Without Leading Zeros)

Local Formatting of Response of Interrogation Commands

The response of interrogation commands may be formatted locally. To format locally, use the command, {Fn.m} or {\$n.m} on the same line as the interrogation command. The symbol F specifies that the response should be returned in decimal format and \$ specifies hexadecimal. n is the number of digits to the left of the decimal, and m is the number of digits to the right of the decimal.

TP {F2.2}	Tell Position in decimal format 2.2
-05.00, 05.00, 00.00, 07.00	Response from Interrogation Command
TP {\$4.2}	Tell Position in hexadecimal format 4.2
FFFB.00,\$0005.00,\$0000.00,\$0007.00	Response from Interrogation Command

Formatting Variables and Array Elements

The Variable Format (VF) command is used to format variables and array elements. The VF command is specified by:

VF m.n

where m is the number of digits to the left of the decimal point (0 thru 10) and n is the number of digits to the right of the decimal point (0 thru 4).

A negative sign for m specifies hexadecimal format. The default format for VF is VF 10.4

Hex values are returned preceded by a \$ and in 2's complement.

Instruction	Interpretation
v1=10	Assign v1
v1=	Return v1
:0000000010.0000	Response - Default format
VF2.2	Change format
v1=	Return v1
:10.00	Response - New format
VF-2.2	Specify hex format
v1=	Return v1
\$0A.00	Response - Hex value

VF1	Change format
v1=	Return v1
:9	Response - Overflow

Local Formatting of Variables

PF and VF commands are global format commands that affect the format of all relevant returned values and variables. Variables may also be formatted locally. To format locally, use the command, {Fn.m} or {\$n.m} following the variable name and the '=' symbol. F specifies decimal and \$ specifies hexadecimal. n is the number of digits to the left of the decimal, and m is the number of digits to the right of the decimal.

Instruction	Interpretation
v1=10	Assign v1
v1=	Return v1
:0000000010.0000	Default Format
v1={F4.2}	Specify local format
:0010.00	New format
v1={\$4.2}	Specify hex format
:\$000A.00	Hex value
v1="ALPHA"	Assign string "ALPHA" to v1
v1={S4}	Specify string format first 4 characters
:ALPH	

The local format is also used with the MG command.

Converting to User Units

Variables and arithmetic operations make it easy to input data in desired user units such as inches or RPM.

The DMC-40x0 position parameters such as PR, PA and VP have units of quadrature counts. Speed parameters such as SP, JG and VS have units of counts/sec. Acceleration parameters such as AC, DC, VA and VD have units of counts/sec². The controller interprets time in milliseconds.

All input parameters must be converted into these units. For example, an operator can be prompted to input a number in revolutions. A program could be used such that the input number is converted into counts by multiplying it by the number of counts/revolution.

Instruction	Interpretation
#RUN	Label
IN "ENTER # OF REVOLUTIONS",n1	Prompt for revs
PR n1*2000	Convert to counts
IN "ENTER SPEED IN RPM",s1	Prompt for RPMs
SP s1*2000/60	Convert to counts/sec
IN "ENTER ACCEL IN RAD/SEC2",a1	Prompt for ACCEL
AC a1*2000/(2*3.14)	Convert to counts/sec ²
BG	Begin motion
EN	End program

Hardware I/O

Digital Outputs

The DMC-40x0 has an 8-bit uncommitted output port and an additional 32 I/O which may be configured as inputs or outputs with the CO command for controlling external events. The DMC-4050 through DMC-4080 has an additional 8 outputs. Each bit on the output port may be set and cleared with the software instructions SB (Set Bit) and CB (Clear Bit), or OB (define output bit).

Example- Set Bit and Clear Bit

Instruction	Interpretation
SB6	Sets bit 6 of output port
CB4	Clears bit 4 of output port

Example- Output Bit

The Output Bit (OB) instruction is useful for setting or clearing outputs depending on the value of a variable, array, input or expression. Any non-zero value results in a set bit.

Instruction	Interpretation
OB1, POS	Set Output 1 if the variable POS is non-zero. Clear Output 1 if POS equals 0.
OB 2, @IN [1]	Set Output 2 if Input 1 is high. If Input 1 is low, clear Output 2.
OB 3, @IN [1]&@IN [2]	Set Output 3 only if Input 1 and Input 2 are high.
OB 4, COUNT [1]	Set Output 4 if element 1 in the array COUNT is non-zero.

The output port can be set by specifying an 16-bit word using the instruction OP (Output Port). This instruction allows a single command to define the state of the entire 16-bit output port, where bit 0 is output 1, bit1 is output2 and so on. A 1 designates that the output is on.

Example- Output Port

Instruction	Interpretation
OP6	Sets outputs 2 and 3 of output port to high. All other bits are 0. ($2^1 + 2^2 = 6$)
OP0	Clears all bits of output port to zero
OP 255	Sets all bits of output port to one. ($2^2 + 2^1 + 2^2 + 2^3 + 2^4 + 2^5 + 2^6 + 2^7$)

The output port is useful for setting relays or controlling external switches and events during a motion sequence.

Example - Turn on output after move

Instruction	Interpretation
#OUTPUT	Label
PR 2000	Position Command
BG	Begin
AM	After move
SB1	Set Output 1
WT 1000	Wait 1000 msec
CB1	Clear Output 1
EN	End

Digital Inputs

The general digital inputs for are accessed by using the @IN[n] function or the TI command. The @IN[n] function returns the logic level of the specified input, n, where n is a number 1 through 48.

Example - Using Inputs to control program flow

Instruction	Interpretation
JP #A,@IN[1]=0	Jump to A if input 1 is low
JP #B,@IN[2]=1	Jump to B if input 2 is high
AI 7	Wait until input 7 is high
AI -6	Wait until input 6 is low

Example - Start Motion on Switch

Motor A must turn at 4000 counts/sec when the user flips a panel switch to on. When panel switch is turned off position, motor A must stop turning.

Solution: Connect panel switch to input 1 of DMC-40x0. High on input 1 means switch is in on position.

Instruction	Interpretation
#S;JG 4000	Set speed
AI 1;BGA	Begin after input 1 goes high
AI -1;STA	Stop after input 1 goes low
AMA;JP #S	After motion, repeat
EN	

The Auxiliary Encoder Inputs

The auxiliary encoder inputs can be used for general use. For each axis, the controller has one auxiliary encoder and each auxiliary encoder consists of two inputs, channel A and channel B. The auxiliary encoder inputs are mapped to the inputs 81-96.

Each input from the auxiliary encoder is a differential line receiver and can accept voltage levels between +/- 12 volts. The inputs have been configured to accept TTL level signals. To connect TTL signals, simply connect the signal to the + input and leave the - input disconnected. For other signal levels, the - input should be connected to a voltage that is 1/2 of the full voltage range (for example, connect the - input to 6 volts if the signal is a 0 - 12 volt logic).

Example:

A DMC-4010 has one auxiliary encoder. This encoder has two inputs (channel A and channel B). Channel A input is mapped to input 81 and Channel B input is mapped to input 82. To use this input for 2 TTL signals, the first signal will be connected to AA+ and the second to AB+. AA- and AB- will be left unconnected. To access this input, use the function @IN[81] and @IN[82].

NOTE: The auxiliary encoder inputs are not available for any axis that is configured for stepper motor.

Input Interrupt Function

The DMC-40x0 provides an input interrupt function which causes the program to automatically execute the instructions following the #ININT label. This function is enabled using the II m,n,o command. The m specifies the beginning input and n specifies the final input in the range. The parameter o is an interrupt mask. If m and n are unused, o contains a number with the mask. For example, II,,5 enables inputs 1 and 3.

A low input on any of the specified inputs will cause automatic execution of the #ININT subroutine. The Return from Interrupt (RI) command is used to return from this subroutine to the place in the program where the interrupt

had occurred. If it is desired to return to somewhere else in the program after the execution of the #ININT subroutine, the Zero Stack (ZS) command is used followed by unconditional jump statements.

Important: Use the RI command (not EN) to return from the #ININT subroutine.

Example - Input Interrupt

Instruction	Interpretation
#A	Label #A
II 1	Enable input 1 for interrupt function
JG 30000,-20000	Set speeds on A and B axes
BG AB	Begin motion on A and B axes
#B	Label #B
TP AB	Report A and B axes positions
WT 1000	Wait 1000 milliseconds
JP #B	Jump to #B
EN	End of program
#ININT	Interrupt subroutine
MG "Interrupt has occurred"	Displays the message
ST AB	Stops motion on A and B axes
#LOOP;JP #LOOP,@IN[1]=0	Loop until Interrupt cleared
JG 15000,10000	Specify new speeds
WT 300	Wait 300 milliseconds
BG AB	Begin motion on A and B axes
RI	Return from Interrupt subroutine

Analog Inputs

The DMC-40x0 provides eight analog inputs. The value of these inputs in volts may be read using the @AN[n] function where n is the analog input 1 through 8. The resolution of the Analog-to-Digital conversion is 12 bits (16-bit ADC is available as an option). Analog inputs are useful for reading special sensors such as temperature, tension or pressure.

The following examples show programs which cause the motor to follow an analog signal. The first example is a point-to-point move. The second example shows a continuous move.

Example - Position Follower (Point-to-Point)

Objective - The motor must follow an analog signal. When the analog signal varies by 10V, motor must move 10000 counts.

Method: Read the analog input and command A to move to that point.

Instruction	Interpretation
#POINTS	Label
SP 7000	Speed
AC 80000;DC 80000	Acceleration
#LOOP	
VP=@AN[1]*1000	Read and analog input, compute position
PA VP	Command position
BGA	Start motion
AMA	After completion
JP #LOOP	Repeat

EN End

Example - Position Follower (Continuous Move)

Method: Read the analog input, compute the commanded position and the position error. Command the motor to run at a speed in proportions to the position error.

Instruction	Interpretation
#CONT	Label
AC 80000;DC 80000	Acceleration rate
JG 0	Start job mode
BGX	Start motion
#LOOP	
vp=@AN[1]*1000	Compute desired position
ve=vp-_TPA	Find position error
vel=ve*20	Compute velocity
JG vel	Change velocity
JP #LOOP	Change velocity
EN	End

Example – Low Pass Digital Filter for the Analog inputs

Because the analog inputs on the Galil controller can be used to close a position loop, they have a very high bandwidth and will therefore read noise that comes in on the analog input. Often when an analog input is used in a motion control system, but not for closed loop control, the higher bandwidth is not required. In this case a simple digital filter may be applied to the analog input, and the output of the filter can be used for in the motion control application. This example shows how to apply a simple single pole low-pass digital filter to an analog input. This code is commonly run in a separate thread (XQ#filt,1 – example of executing in thread 1).

```
#filt
REM an1 = filtered output. Use this instead of @AN[1]
an1=@AN[1];'set initial value
REM k1+k2=1 this condition must be met
REM use division of m/2^n for elimination of round off
REM increase k1 = less filtering
REM increase k2 = more filtering
k1=32/64;k2=32/64
AT0;'set initial time reference
#loop
REM calculate filtered output and then way 2 samples from last
REM time reference (last AT-2,1 or AT0)
an1=(k1*@AN[1])+(k2*an1);AT-2,1
JP#loop
```

Extended I/O of the DMC-40x0 Controller

The DMC-40x0 controller offers 32 extended I/O points which can be configured as inputs or outputs in 8 bit increments through software. The I/O points are accessed through 1 44 pin high density connector.

Configuring the I/O of the DMC-40x0

The 32 extended I/O points of the DMC-40x0 series controller can be configured in blocks of 8. The extended I/O is denoted as blocks 2-5 or bits 17-48.

The command, CO, is used to configure the extended I/O as inputs or outputs. The CO command has one field:

CO n

where n is a decimal value which represents a binary number. Each bit of the binary number represents one block of extended I/O. When set to 1, the corresponding block is configured as an output.

The least significant bit represents block 2 and the most significant bit represents block 5. The decimal value can be calculated by the following formula. $n = n_2 + 2*n_3 + 4*n_4 + 5*n_5$ where n_x represents the block. If the n_x value is a one, then the block of 8 I/O points is to be configured as an output. If the n_x value is a zero, then the block of 8 I/O points will be configured as an input. For example, if block 4 and 5 is to be configured as an output, CO 12 is issued.

8-Bit I/O Block	Block	Binary Representation	Decimal Value for Block
17-24	2	2^0	1
25-32	3	2^1	2
33-40	4	2^2	4
41-48	5	2^3	8

The simplest method for determining n:

Step 1. Determine which 8-bit I/O blocks to be configured as outputs.

Step 2. From the table, determine the decimal value for each I/O block to be set as an output.

Step 3. Add up all of the values determined in step 2. This is the value to be used for n.

For example, if blocks 2 and 3 are to be outputs, then n is 3 and the command, CO3, should be issued.

NOTE: This calculation is identical to the formula: $n = n_2 + 2*n_3 + 4*n_4 + 5*n_5$ where n_x represents the block.

Saving the State of the Outputs in Non-Volatile Memory

The configuration of the extended I/O and the state of the outputs can be stored in the non-volatile flash memory with the BN command. If no value has been set, the default of CO 0 is used (all blocks are inputs).

Accessing Extended I/O

When configured as an output, each I/O point may be defined with the SBn and CBn commands (where n=1 through 8 and 17 through 48). Outputs may also be defined with the conditional command, OBn (where n=1 through 8 and 17 through 48).

4080

For 5-8 axis controllers, each I/O point may be defined with the SBn and CBn commands (where n=1 through 48).

The command, OP, may also be used to set output bits, specified as blocks of data. The OP command accepts 3 parameters. The first parameter sets the values of the main output port of the controller (Outputs 1-8, block 0). The additional parameters set the value of the extended I/O as outlined:

OP m,a,b

where m is the decimal representation of the bits 1-8 (values from 0 to 255) and a,b,c,d represent the extended I/O in consecutive groups of 16 bits (values from 0 to 65535). Arguments which are given for I/O points which are configured as inputs will be ignored. The following table describes the arguments used to set the state of outputs.

Argument	Blocks	Bits	Description
m	0	1-8	General Outputs
a	2,3	17-32	Extended I/O
b	4,5	33-48	Extended I/O

For example, if block 8 is configured as an output, the following command may be issued:

OP 7,,7

This command will set bits 1,2,3 (block 0) and bits 33,34,35 (block 4) to 1. Bits 4 through 8 and bits 36 through 48 will be set to 0. All other bits are unaffected.

When accessing I/O blocks configured as inputs, use the TIn command. The argument 'n' refers to the block to be read (n=0,2,3 or 4). The value returned will be a decimal representation of the corresponding bits.

Individual bits can be queried using the @IN[n] function (where n=1 through 8 or 17 through 48). If the following command is issued;

4080

Individual bits can be queried using the @IN[n] function (where n=1 through 48).

MG @IN[17]

the controller will return the state of the least significant bit of block 2 (assuming block 2 is configured as an input).

Example Applications

Wire Cutter

An operator activates a start switch. This causes a motor to advance the wire a distance of 10". When the motion stops, the controller generates an output signal which activates the cutter. Allowing 100 ms for the cutting completes the cycle.

Suppose that the motor drives the wire by a roller with a 2" diameter. Also assume that the encoder resolution is 1000 lines per revolution. Since the circumference of the roller equals 2π inches, and it corresponds to 4000 quadrature, one inch of travel equals:

$$4000/2\pi = 637 \text{ count/inch}$$

This implies that a distance of 10 inches equals 6370 counts, and a slew speed of 5 inches per second, for example, equals 3185 count/sec.

The input signal may be applied to I1, for example, and the output signal is chosen as output 1. The motor velocity profile and the related input and output signals are shown in Fig. 7.1.

The program starts at a state that we define as #A. Here the controller waits for the input pulse on I1. As soon as the pulse is given, the controller starts the forward motion.

Upon completion of the forward move, the controller outputs a pulse for 20 ms and then waits an additional 80 ms before returning to #A for a new cycle.

INSTRUCTION	FUNCTION
#A	Label
AI1	Wait for input 1
PR 6370	Distance
SP 3185	Speed
BGX	Start Motion
AMX	After motion is complete
SB1	Set output bit 1
WT 20	Wait 20 ms
CB1	Clear output bit 1
WT 80	Wait 80 ms
JP #A	Repeat the process

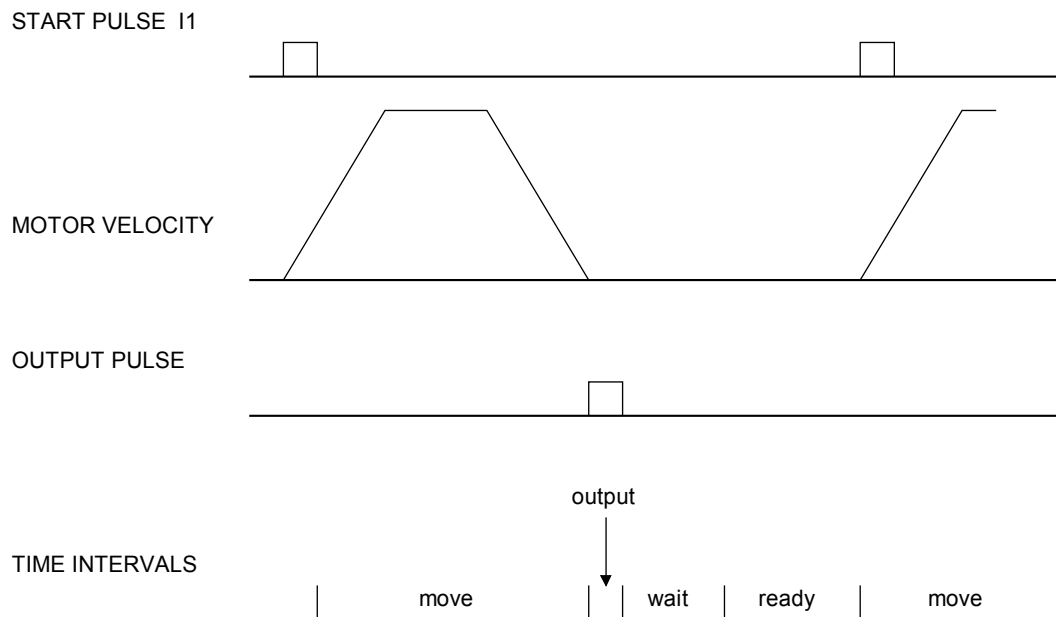

Figure 7.1 - Motor Velocity and the Associated Input/Output signals

X-Y Table Controller

An X-Y-Z system must cut the pattern shown in Fig. 7.2. The X-Y table moves the plate while the Z-axis raises and lowers the cutting tool.

The solid curves in Fig. 7.2 indicate sections where cutting takes place. Those must be performed at a feed rate of 1 inch per second. The dashed line corresponds to non-cutting moves and should be performed at 5 inch per second. The acceleration rate is 0.1 g.

The motion starts at point A, with the Z-axis raised. An X-Y motion to point B is followed by lowering the Z-axis and performing a cut along the circle. Once the circular motion is completed, the Z-axis is raised and the motion continues to point C, etc.

Assume that all of the 3 axes are driven by lead screws with 10 turns-per-inch pitch. Also assume encoder resolution of 1000 lines per revolution. This results in the relationship:

$$1 \text{ inch} = 40,000 \text{ counts}$$

and the speeds of

$$1 \text{ in/sec} = 40,000 \text{ count/sec}$$

$$5 \text{ in/sec} = 200,000 \text{ count/sec}$$

an acceleration rate of 0.1g equals

$$0.1g = 38.6 \text{ in/s}^2 = 1,544,000 \text{ count/s}^2$$

Note that the circular path has a radius of 2" or 80000 counts, and the motion starts at the angle of 270° and traverses 360° in the CW (negative direction). Such a path is specified with the instruction

```
CR 80000, 270, -360
```

Further assume that the Z must move 2” at a linear speed of 2” per second. The required motion is performed by the following instructions:

INSTRUCTION	FUNCTION
#A	Label
VM XY	Circular interpolation for XY
VP 160000,160000	Positions
VE	End Vector Motion
VS 200000	Vector Speed
VA 1544000	Vector Acceleration
BGS	Start Motion
AMS	When motion is complete
PR,,-80000	Move Z down
SP,,80000	Z speed
BGZ	Start Z motion
AMZ	Wait for completion of Z motion
CR 80000,270,-360	Circle
VE	
VS 40000	Feed rate
BGS	Start circular move
AMS	Wait for completion
PR,,80000	Move Z up
BGZ	Start Z move
AMZ	Wait for Z completion
PR -21600	Move X
SP 20000	Speed X
BGX	Start X
AMX	Wait for X completion
PR,,-80000	Lower Z
BGZ	
AMZ	
CR 80000,270,-360	Z second circle move
VE	
VS 40000	
BGS	
AMS	
PR,,80000	Raise Z
BGZ	
AMZ	
VP -37600,-16000	Return XY to start
VE	
VS 200000	
BGS	
AMS	
EN	

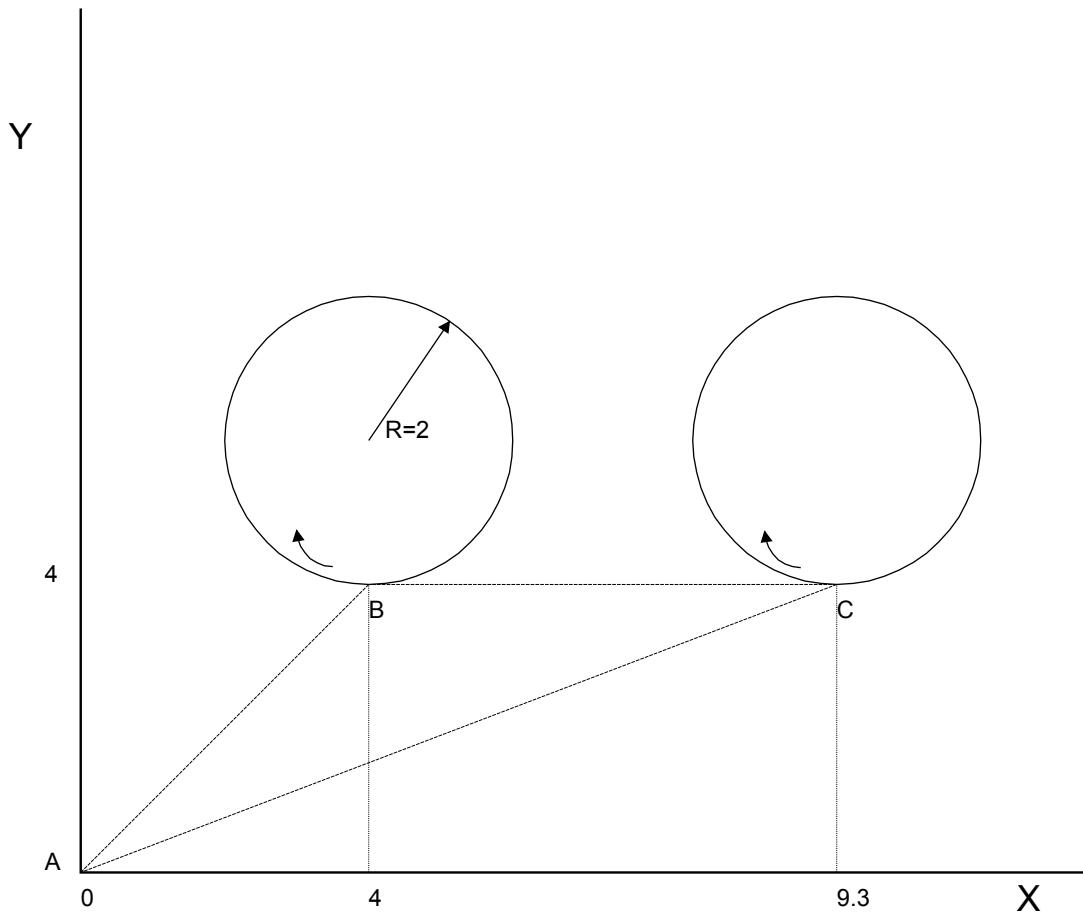

Figure 7.2 - Motor Velocity and the Associated Input/Output signals

Speed Control by Joystick

The speed of a motor is controlled by a joystick. The joystick produces a signal in the range between -10V and +10V. The objective is to drive the motor at a speed proportional to the input voltage.

Assume that a full voltage of 10 Volts must produce a motor speed of 3000 rpm with an encoder resolution of 1000 lines or 4000 count/rev. This speed equals:

$$3000 \text{ rpm} = 50 \text{ rev/sec} = 200000 \text{ count/sec}$$

The program reads the input voltage periodically and assigns its value to the variable VIN. To get a speed of 200,000 ct/sec for 10 volts, we select the speed as:

$$\text{Speed} = 20000 \times \text{VIN}$$

The corresponding velocity for the motor is assigned to the VEL variable.

Instruction

```
#A
JG0
BGX
#B
VIN=@AN[1]
VEL=VIN*20000
JG VEL
JP #B
EN
```

Position Control by Joystick

This system requires the position of the motor to be proportional to the joystick angle. Furthermore, the ratio between the two positions must be programmable. For example, if the control ratio is 5:1, it implies that when the joystick voltage is 5 Volts, corresponding to 1028 counts, the required motor position must be 5120 counts. The variable V3 changes the position ratio.

INSTRUCTION	FUNCTION
#A	Label
V3=5	Initial position ratio
DP0	Define the starting position
JG0	Set motor in jog mode as zero
BGX	Start
#B	
VIN=@AN[1]	Read analog input
V2=V1*V3	Compute the desired position
V4=V2-_TPX-_TEX	Find the following error
V5=V4*20	Compute a proportional speed
JG V5	Change the speed
JP #B	Repeat the process
EN	End

Backlash Compensation by Sampled Dual-Loop

The continuous dual loop, enabled by the DV1 function is an effective way to compensate for backlash. In some cases, however, when the backlash magnitude is large, it may be difficult to stabilize the system. In those cases, it may be easier to use the sampled dual loop method described below.

This design example addresses the basic problems of backlash in motion control systems. The objective is to control the position of a linear slide precisely. The slide is to be controlled by a rotary motor, which is coupled to the slide by a lead screw. Such a lead screw has a backlash of 4 micron, and the required position accuracy is for 0.5 micron.

The basic dilemma is where to mount the sensor. If you use a rotary sensor, you get a 4 micron backlash error. On the other hand, if you use a linear encoder, the backlash in the feedback loop will cause oscillations due to instability.

An alternative approach is the dual-loop, where we use two sensors, rotary and linear. The rotary sensor assures stability (because the position loop is closed before the backlash) whereas the linear sensor provides accurate load position information. The operation principle is to drive the motor to a given rotary position near the final point.

Once there, the load position is read to find the position error and the controller commands the motor to move to a new rotary position which eliminates the position error.

Since the required accuracy is 0.5 micron, the resolution of the linear sensor should preferably be twice finer. A linear sensor with a resolution of 0.25 micron allows a position error of +/-2 counts.

The dual-loop approach requires the resolution of the rotary sensor to be equal or better than that of the linear system. Assuming that the pitch of the lead screw is 2.5mm (approximately 10 turns per inch), a rotary encoder of 2500 lines per turn or 10,000 count per revolution results in a rotary resolution of 0.25 micron. This results in equal resolution on both linear and rotary sensors.

To illustrate the control method, assume that the rotary encoder is used as a feedback for the X-axis, and that the linear sensor is read and stored in the variable LINPOS. Further assume that at the start, both the position of X and the value of LINPOS are equal to zero. Now assume that the objective is to move the linear load to the position of 1000.

The first step is to command the X motor to move to the rotary position of 1000. Once it arrives we check the position of the load. If, for example, the load position is 980 counts, it implies that a correction of 20 counts must be made. However, when the X-axis is commanded to be at the position of 1000, suppose that the actual position is only 995, implying that X has a position error of 5 counts, which will be eliminated once the motor settles. This implies that the correction needs to be only 15 counts, since 5 counts out of the 20 would be corrected by the X-axis. Accordingly, the motion correction should be:

$$\text{Correction} = \text{Load Position Error} - \text{Rotary Position Error}$$

The correction can be performed a few times until the error drops below +/-2 counts. Often, this is performed in one correction cycle.

Example:

INSTRUCTION	FUNCTION
#A	Label
DP0	Define starting positions as zero
LINPOS=0	
PR 1000	Required distance
BGX	Start motion
#B	
AMX	Wait for completion
WT 50	Wait 50 msec
LINPOS = _DEX	Read linear position
ERR=1000-LINPOS-_TEX	Find the correction
JP #C,@ABS[ERR]<2	Exit if error is small
PR ERR	Command correction
BGX	
JP #B	Repeat the process
#C	
EN	

THIS PAGE LEFT BLANK INTENTIONALLY

Chapter 8 Hardware & Software Protection

Introduction

The DMC-40x0 provides several hardware and software features to check for error conditions and to inhibit the motor on error. These features help protect the various system components from damage.

WARNING: Machinery in motion can be dangerous! It is the responsibility of the user to design effective error handling and safety protection as part of the machine. Since the DMC-40x0 is an integral part of the machine, the engineer should design his overall system with protection against a possible component failure on the DMC-40x0. Galil shall not be liable or responsible for any incidental or consequential damages.

Hardware Protection

The DMC-40x0 includes hardware input and output protection lines for various error and mechanical limit conditions. These include:

Output Protection Lines

Amp Enable

This signal goes low when the motor off command is given, when the position error exceeds the value specified by the Error Limit (ER) command, or when off-on-error condition is enabled (OE1) and the abort command is given. Each axis amplifier has separate amplifier enable lines. This signal also goes low when the watch-dog timer is activated, or upon reset.

Note: The standard configuration of the AEN signal is TTL active low. Both the polarity and the amplitude can be changed. To make these changes, see section entitled [Amplifier Circuit in Chapter 3](#).

Error Output

The error output is a TTL signal which indicates an error condition in the controller. This signal is available on the interconnect module as ERR. When the error signal is low, this indicates one of the following error conditions:

1. At least one axis has a position error greater than the error limit. The error limit is set by using the command ER.
2. The reset line on the controller is held low or is being affected by noise.
3. There is a failure on the controller and the processor is resetting itself.
4. There is a failure with the output IC which drives the error signal.

Input Protection Lines

General Abort

A low input stops commanded motion instantly without a controlled deceleration. For any axis in which the Off-On-Error function is enabled, the amplifiers will be disabled. This could cause the motor to ‘coast’ to a stop. If the Off-On-Error function is not enabled, the motor will instantaneously stop and servo at the current position. The Off-On-Error function is further discussed in this chapter.

The Abort input by default will also halt program execution; this can be changed by changing the 5th field of the CN command. See the CN command in the command reference for more information.

Selective Abort

The controller can be configured to provide an individual abort for each axis. Activation of the selective abort signal will act the same as the Abort Input but only on the specific axis. To configure the controller for selective abort, issue the command CN,,,1. This configures the inputs 5,6,7,8,13,14,15,16 to act as selective aborts for axes A,B,C,D,E,F,G,H respectively.

ELO (Electronic Lock Out)

Used in conjunction with Galil amplifiers, this input allows the user the shutdown the amplifier at a hardware level. For more detailed information on how specific Galil amplifiers behave when the ELO is triggered, see Integrated in the Appendices.

Forward Limit Switch

Low input inhibits motion in forward direction. If the motor is moving in the forward direction when the limit switch is activated, the motion will decelerate and stop. In addition, if the motor is moving in the forward direction, the controller will automatically jump to the limit switch subroutine, #LIMSWI (if such a routine has been written by the user). The CN command can be used to change the polarity of the limit switches.

Reverse Limit Switch

Low input inhibits motion in reverse direction. If the motor is moving in the reverse direction when the limit switch is activated, the motion will decelerate and stop. In addition, if the motor is moving in the reverse direction, the controller will automatically jump to the limit switch subroutine, #LIMSWI (if such a routine has been written by the user). The CN command can be used to change the polarity of the limit switches.

Software Protection

The DMC-40x0 provides a programmable error limit. The error limit can be set for any number between 0 and 2147483647 using the ER n command. The default value for ER is 16384.

Example:

```
ER 200,300,400,500    Set X-axis error limit for 200, Y-axis error limit to 300, Z-
                      axis error limit to 400 counts, W-axis error limit to 500
                      counts
ER,1,,10              Set Y-axis error limit to 1 count, set W-axis error limit to
                      10 counts.
```

The units of the error limit are quadrature counts. The error is the difference between the command position and actual encoder position. If the absolute value of the error exceeds the value specified by ER, the controller will generate several signals to warn the host system of the error condition. These signals include:

Signal or Function	State if Error Occurs
# POSERR	Jumps to automatic excess position error subroutine
Error Light	Turns on
OE Function	Shuts motor off if OE1
AEN Output Line	Goes low

The Jump on Condition statement is useful for branching on a given error within a program. The position error of X,Y,Z and W can be monitored during execution using the TE command.

Programmable Position Limits

The DMC-40x0 provides programmable forward and reverse position limits. These are set by the BL and FL software commands. Once a position limit is specified, the DMC-40x0 will not accept position commands beyond the limit. Motion beyond the limit is also prevented.

Example:

```
DP0,0,0           Define Position
BL -2000,-4000,-8000 Set Reverse position limit
FL 2000,4000,8000  Set Forward position limit
JG 2000,2000,2000  Jog
BG XYZ           Begin
```

(motion stops at forward limits)

Off-On-Error

The DMC-40x0 controller has a built in function which can turn off the motors under certain error conditions. This function is known as 'Off-On-Error'. To activate the OE function for each axis, specify 1 for X,Y,Z and W axis. To disable this function, specify 0 for the axes. When this function is enabled, the specified motor will be disabled under the following 3 conditions:

1. The position error for the specified axis exceeds the limit set with the command, ER
2. The abort command is given
3. The abort input is activated with a low signal.

Note: If the motors are disabled while they are moving, they may 'coast' to a stop because they are no longer under servo control.

To re-enable the system, use the Reset (RS) or Servo Here (SH) command.

Examples:

```
OE 1,1,1,1      Enable off-on-error for X,Y,Z and W
OE 0,1,0,1      Enable off-on-error for Y and W axes and disable off-on-error for W and Z axes
```

Automatic Error Routine

The #POSERR label causes the statements following to be automatically executed if error on any axis exceeds the error limit specified by ER. The error routine must be closed with the RE command. The RE command returns from the error subroutine to the main program.

NOTE: The Error Subroutine will be entered again unless the error condition is gone.

Example:

```
#A;JP #A;EN      "Dummy" program
#POSERR          Start error routine on error
MG "error"       Send message
SB 1             Fire relay
STX             Stop motor
AMX             After motor stops
SHX             Servo motor here to clear error
RE              Return to main program
```

Limit Switch Routine

The DMC-40x0 provides forward and reverse limit switches which inhibit motion in the respective direction. There is also a special label for automatic execution of a limit switch subroutine. The #LIMSWI label specifies the start of the limit switch subroutine. This label causes the statements following to be automatically executed if any limit switch is activated and that axis motor is moving in that direction. The RE command ends the subroutine.

The state of the forward and reverse limit switches may also be tested during the jump-on-condition statement. The _LR condition specifies the reverse limit and _LF specifies the forward limit. X,Y,Z, or W following LR or LF specifies the axis. The CN command can be used to configure the polarity of the limit switches.

Limit Switch Example:

```
#A;JP #A;EN          Dummy Program
#LIMSWI              Limit Switch Utility
V1=_LFX              Check if forward limit
V2=_LRX              Check if reverse limit
JP#LF,V1=0           Jump to #LF if forward
JP#LR,V2=0           Jump to #LR if reverse
JP#END               Jump to end
#LF                  #LF
MG "FORWARD LIMIT"  Send message
STX;AMX              Stop motion
PR-1000;BGX;AMX     Move in reverse
JP#END               End
#LR                  #LR
MG "REVERSE LIMIT" Send message
STX;AMX              Stop motion
PR1000;BGX;AMX     Move forward
#END                 End
RE                   Return to main program
```

Chapter 9 Troubleshooting

Overview

The following discussion may help you get your system to work.

Potential problems have been divided into groups as follows:

1. Installation
2. Stability and Compensation
3. Operation

The various symptoms along with the cause and the remedy are described in the following tables.

Installation

SYMPTOM	DIAGNOSIS	CAUSE	REMEDY
Motor runs away with no connections from controller to amplifier input.	Adjusting offset causes the motor to change speed.	1. Amplifier has an internal offset. 2. Damaged amplifier.	Adjust amplifier offset. Amplifier offset may also be compensated by use of the offset configuration on the controller (see the OF command). Replace amplifier.
Motor is enabled even when MO command is given	The SH command disables the motor	1. The amplifier requires the a different Amplifier Enable setting on the Interconnect Module	Refer to Chapter 3 or contact Galil.
Unable to read main or auxiliary encoder input.	The encoder does not work when swapped with another encoder input.	1. Wrong encoder connections. 2. Encoder is damaged 3. Encoder configuration incorrect.	Check encoder wiring. For single ended encoders (CHA and CHB only) do not make any connections to the CHA- and CHB- inputs. Replace encoder Check CE command

Unable to read main or auxiliary encoder input.	The encoder works correctly when swapped with another encoder input.	1. Wrong encoder connections. 2. Encoder configuration incorrect. 3. Encoder input or controller is damaged	Check encoder wiring. For single ended encoders (MA+ and MB+ only) do not make any connections to the MA- and MB- inputs. Check CE command Contact Galil
Encoder Position Drifts	Swapping cables fixes the problem	1. Poor Connections / intermittent cable	Review all connections and connector contacts.
Encoder Position Drifts	Significant noise can be seen on MA+ and / or MB+ encoder signals	1. Noise	Shield encoder cables Avoid placing power cables near encoder cables Avoid Ground Loops Use differential encoders Use +/-12V encoders

Stability

SYMPTOM	DIAGNOSIS	CAUSE	REMEDY
Servo motor runs away when the loop is closed.	Reversed Motor Type corrects situation (MT -1)	1. Wrong feedback polarity.	Reverse Motor or Encoder Wiring (remember to set Motor Type back to default value: MT 1)
Motor oscillates.		2. Too high gain or too little damping.	Decrease KI and KP. Increase KD.

Operation

SYMPTOM	DIAGNOSIS	CAUSE	REMEDY
Controller rejects commands.	Response of controller from TC1 diagnoses error.	1. Anything	Correct problem reported by TC1
Motor Doesn't Move	Response of controller from TC1 diagnoses error.	2. Anything	Correct problem reported by SC

Chapter 10 Theory of Operation

Overview

The following discussion covers the operation of motion control systems. A typical motion control system consists of the elements shown in Fig 10.1.

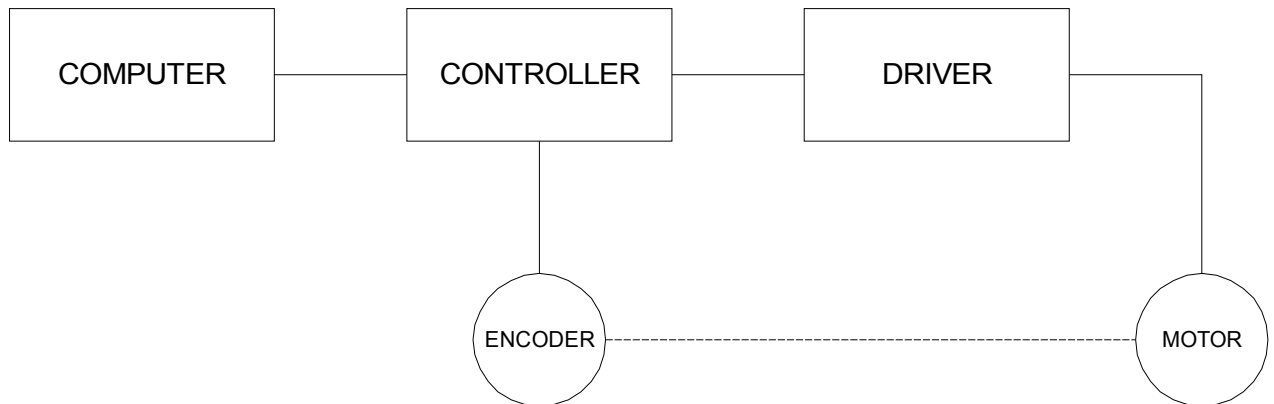

Figure 10.1 - Elements of Servo Systems

The operation of such a system can be divided into three levels, as illustrated in Fig. 10.2. The levels are:

1. Closing the Loop
2. Motion Profiling
3. Motion Programming

The first level, the closing of the loop, assures that the motor follows the commanded position. This is done by closing the position loop using a sensor. The operation at the basic level of closing the loop involves the subjects of modeling, analysis, and design. These subjects will be covered in the following discussions.

The motion profiling is the generation of the desired position function. This function, $R(t)$, describes where the motor should be at every sampling period. Note that the profiling and the closing of the loop are independent functions. The profiling function determines where the motor should be and the closing of the loop forces the motor to follow the commanded position.

The highest level of control is the motion program. This can be stored in the host computer or in the controller. This program describes the tasks in terms of the motors that need to be controlled, the distances and the speed.

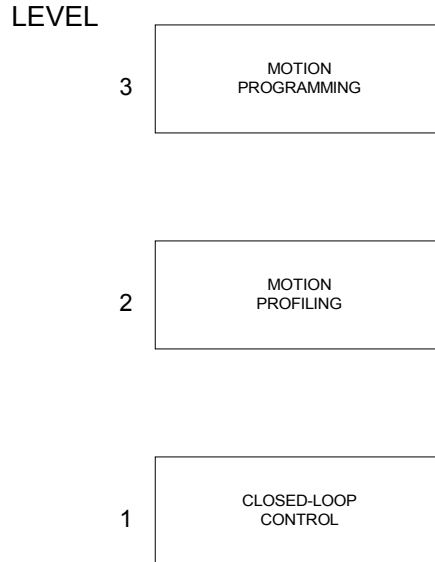

Figure 10.2 - Levels of Control Functions

The three levels of control may be viewed as different levels of management. The top manager, the motion program, may specify the following instruction, for example.

```
PR 6000,4000
SP 20000,20000
AC 200000,00000
BG X
AD 2000
BG Y
EN
```

This program corresponds to the velocity profiles shown in Fig. 10.3. Note that the profiled positions show where the motors must be at any instant of time.

Finally, it remains up to the servo system to verify that the motor follows the profiled position by closing the servo loop.

The following section explains the operation of the servo system. First, it is explained qualitatively, and then the explanation is repeated using analytical tools for those who are more theoretically inclined.

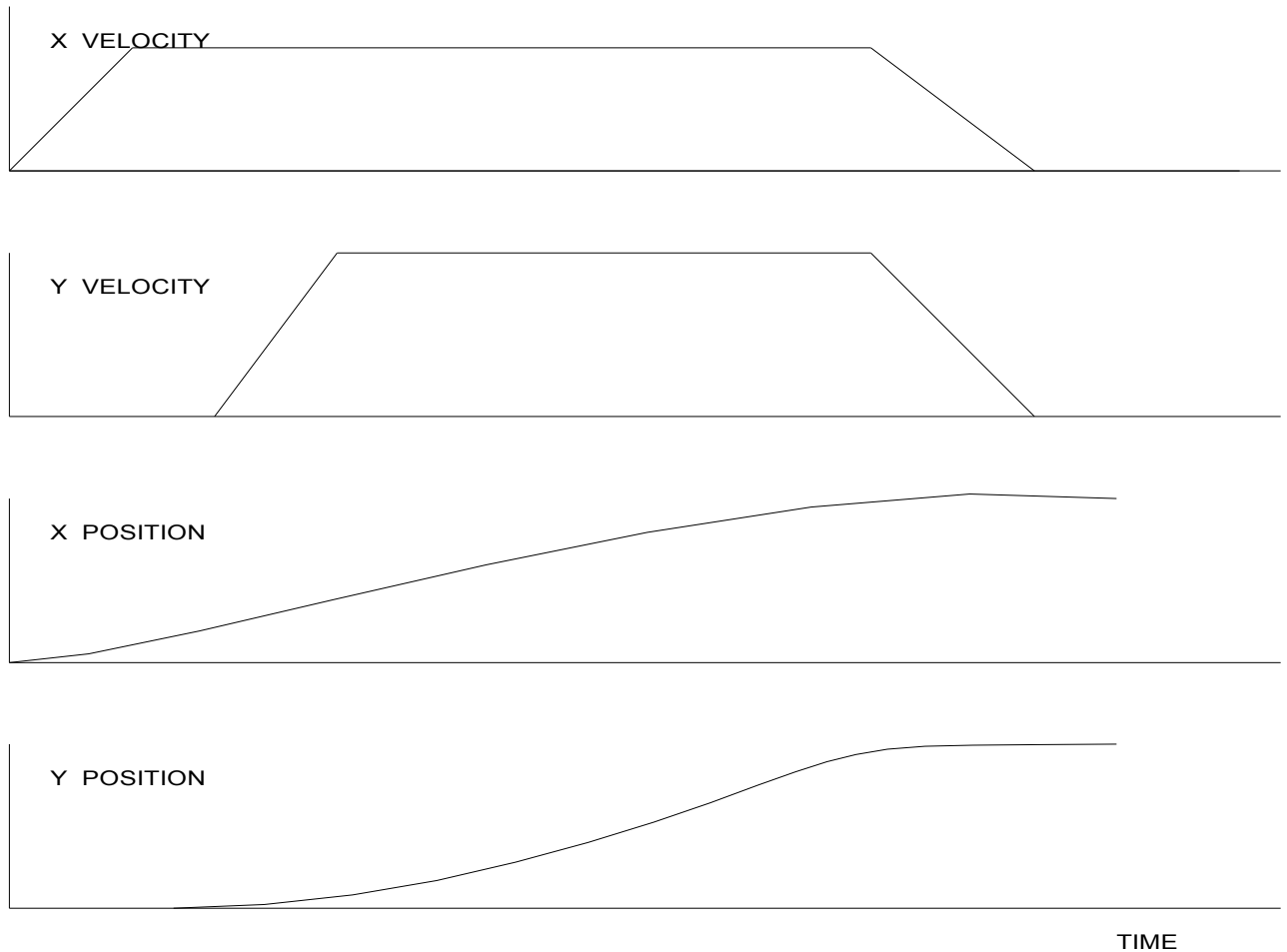

Figure 10.3 - Velocity and Position Profiles

Operation of Closed-Loop Systems

To understand the operation of a servo system, we may compare it to a familiar closed-loop operation, adjusting the water temperature in the shower. One control objective is to keep the temperature at a comfortable level, say 90 degrees F. To achieve that, our skin serves as a temperature sensor and reports to the brain (controller). The brain compares the actual temperature, which is called the feedback signal, with the desired level of 90 degrees F. The difference between the two levels is called the error signal. If the feedback temperature is too low, the error is positive, and it triggers an action which raises the water temperature until the temperature error is reduced sufficiently.

The closing of the servo loop is very similar. Suppose that we want the motor position to be at 90 degrees. The motor position is measured by a position sensor, often an encoder, and the position feedback is sent to the controller. Like the brain, the controller determines the position error, which is the difference between the commanded position of 90 degrees and the position feedback. The controller then outputs a signal that is proportional to the position error. This signal produces a proportional current in the motor, which causes a motion until the error is reduced. Once the error becomes small, the resulting current will be too small to overcome the friction, causing the motor to stop.

The analogy between adjusting the water temperature and closing the position loop carries further. We have all learned the hard way, that the hot water faucet should be turned at the “right” rate. If you turn it too slowly, the temperature response will be slow, causing discomfort. Such a slow reaction is called over-damped response.

The results may be worse if we turn the faucet too fast. The overreaction results in temperature oscillations. When the response of the system oscillates, we say that the system is unstable. Clearly, unstable responses are bad when we want a constant level.

What causes the oscillations? The basic cause for the instability is a combination of delayed reaction and high gain. In the case of the temperature control, the delay is due to the water flowing in the pipes. When the human reaction is too strong, the response becomes unstable.

Servo systems also become unstable if their gain is too high. The delay in servo systems is between the application of the current and its effect on the position. Note that the current must be applied long enough to cause a significant effect on the velocity, and the velocity change must last long enough to cause a position change. This delay, when coupled with high gain, causes instability.

This motion controller includes a special filter which is designed to help the stability and accuracy. Typically, such a filter produces, in addition to the proportional gain, damping and integrator. The combination of the three functions is referred to as a PID filter.

The filter parameters are represented by the three constants K_P , K_I and K_D , which correspond to the proportional, integral and derivative term respectively.

The damping element of the filter acts as a predictor, thereby reducing the delay associated with the motor response.

The integrator function, represented by the parameter K_I , improves the system accuracy. With the K_I parameter, the motor does not stop until it reaches the desired position exactly, regardless of the level of friction or opposing torque.

The integrator also reduces the system stability. Therefore, it can be used only when the loop is stable and has a high gain.

The output of the filter is applied to a digital-to-analog converter (DAC). The resulting output signal in the range between +10 and -10 Volts is then applied to the amplifier and the motor.

The motor position, whether rotary or linear is measured by a sensor. The resulting signal, called position feedback, is returned to the controller for closing the loop.

The following section describes the operation in a detailed mathematical form, including modeling, analysis and design.

System Modeling

The elements of a servo system include the motor, driver, encoder and the controller. These elements are shown in Fig. 10.4. The mathematical model of the various components is given below.

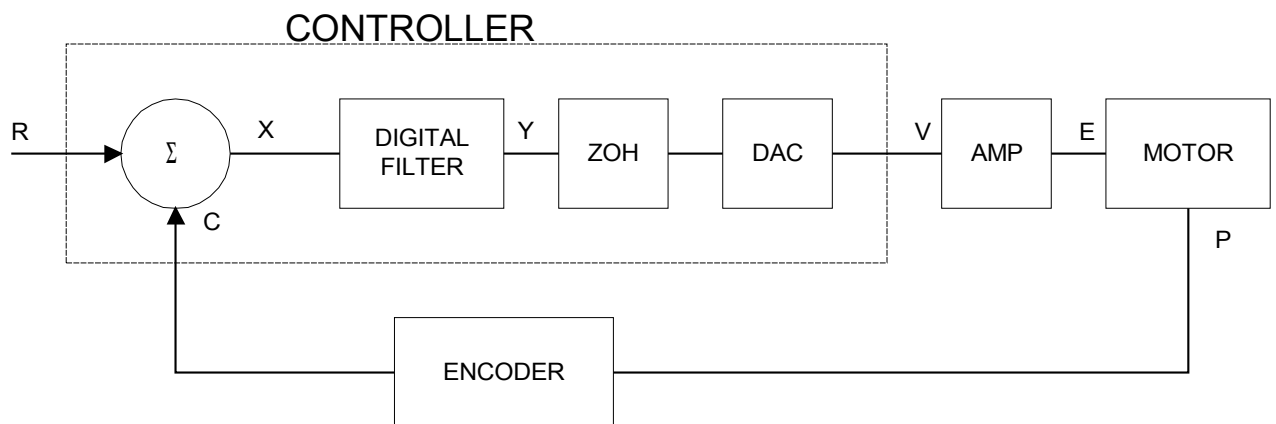

Figure 10.4 - Functional Elements of a Motion Control System

Motor-Amplifier

The motor amplifier may be configured in three modes:

1. Voltage Drive
2. Current Drive
3. Velocity Loop

The operation and modeling in the three modes is as follows:

Voltage Drive

The amplifier is a voltage source with a gain of K_v [V/V]. The transfer function relating the input voltage, V , to the motor position, P , is

$$P/V = K_v / [K_t S (ST_m + 1) (ST_e + 1)]$$

where

$$T_m = RJ / K_t^2 \quad [s]$$

and

$$T_e = L/R \quad [s]$$

and the motor parameters and units are

K_t	Torque constant [Nm/A]
R	Armature Resistance Ω
J	Combined inertia of motor and load [kg.m ²]
L	Armature Inductance [H]

When the motor parameters are given in English units, it is necessary to convert the quantities to MKS units. For example, consider a motor with the parameters:

$$K_t = 14.16 \text{ oz-in/A} = 0.1 \text{ Nm/A}$$

$$R = 2 \Omega$$

$$J = 0.0283 \text{ oz-in-s}^2 = 2.10 \cdot 10^{-4} \text{ kg} \cdot \text{m}^2$$

$$L = 0.004 \text{ H}$$

Then the corresponding time constants are

$$T_m = 0.04 \text{ sec}$$

and

$$T_e = 0.002 \text{ sec}$$

Assuming that the amplifier gain is $K_v = 4$, the resulting transfer function is

$$P/V = 40 / [s(0.04s+1)(0.002s+1)]$$

Current Drive

The current drive generates a current I , which is proportional to the input voltage, V , with a gain of K_a . The resulting transfer function in this case is

$$P/V = K_a K_t / J s^2$$

where K_t and J are as defined previously. For example, a current amplifier with $K_a = 2 \text{ A/V}$ with the motor described by the previous example will have the transfer function:

$$P/V = 1000/s^2 \text{ [rad/V]}$$

If the motor is a DC brushless motor, it is driven by an amplifier that performs the commutation. The combined transfer function of motor amplifier combination is the same as that of a similar brush motor, as described by the previous equations.

Velocity Loop

The motor driver system may include a velocity loop where the motor velocity is sensed by a tachometer and is fed back to the amplifier. Such a system is illustrated in Fig. 10.5. Note that the transfer function between the input voltage V and the velocity ω is:

$$\omega / V = [K_a K_t / Js] / [1 + K_a K_t K_g / Js] = 1 / [K_g (sT_1 + 1)]$$

where the velocity time constant, T_1 , equals

$$T_1 = J / K_a K_t K_g$$

This leads to the transfer function

$$P/V = 1 / [K_g s(sT_1 + 1)]$$

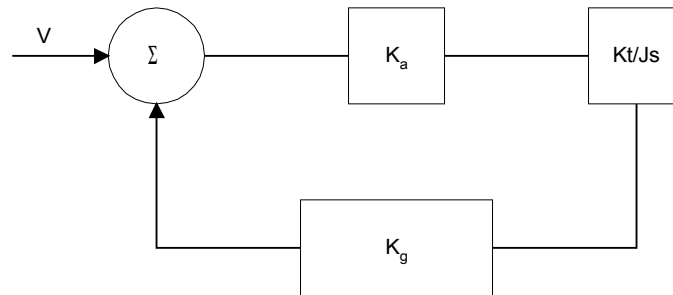
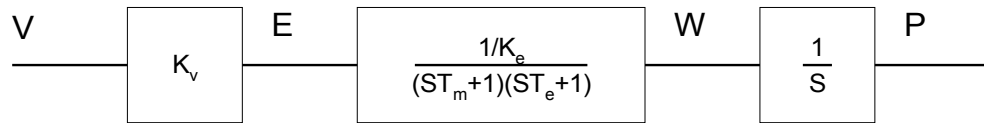

Figure 10.5 - Elements of velocity loops

The resulting functions derived above are illustrated by the block diagram of Fig. 10.6.

VOLTAGE SOURCE



CURRENT SOURCE

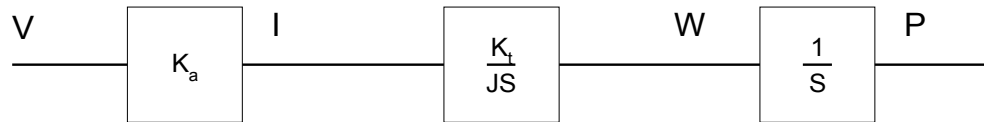

VELOCITY LOOP

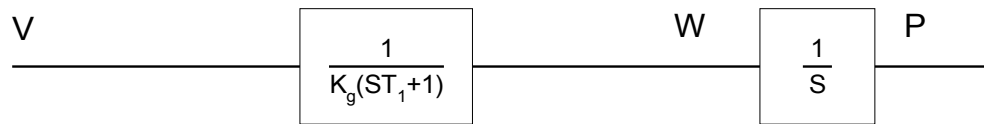

Figure 10.6 - Mathematical model of the motor and amplifier in three operational modes

Encoder

The encoder generates N pulses per revolution. It outputs two signals, Channel A and B, which are in quadrature. Due to the quadrature relationship between the encoder channels, the position resolution is increased to $4N$ quadrature counts/rev.

The model of the encoder can be represented by a gain of

$$K_f = 4N/2\pi \quad [\text{count/rad}]$$

For example, a 1000 lines/rev encoder is modeled as

$$K_f = 638$$

DAC

The DAC or D-to-A converter converts a 16-bit number to an analog voltage. The input range of the numbers is ± 65536 and the output voltage range is $\pm 10\text{V}$ or 20V . Therefore, the effective gain of the DAC is

$$K = 20/65536 = 0.0003 \quad [\text{V/count}]$$

Digital Filter

The digital filter has three element in series: PID, low-pass and a notch filter. The transfer function of the filter. The transfer function of the filter elements are:

$$\text{PID} \quad D(z) = \frac{K(Z - A)}{Z} + \frac{CZ}{Z - 1}$$

$$\text{Low-pass} \quad L(z) = \frac{1 - B}{Z - B}$$

$$\text{Notch} \quad N(z) = \frac{(Z - z)(Z - \bar{z})}{(Z - p)(Z - \bar{p})}$$

The filter parameters, K, A, C and B are selected by the instructions KP, KD, KI and PL, respectively. The relationship between the filter coefficients and the instructions are:

$$K = (KP + KD)$$

$$A = KD/(KP + KD)$$

$$C = KI/2$$

$$B = PL$$

The PID and low-pass elements are equivalent to the continuous transfer function G(s).

$$G(s) = (P + sD + I/s) * a / (s + a)$$

where,

$$P = KP$$

$$D = T \cdot KD$$

$$I = KI/2T$$

$$a = \frac{1}{T} \ln \left(\frac{1}{B} \right)$$

where T is the sampling period, and B is the pole setting

For example, if the filter parameters of the DMC-40x0 are

$$KP = 16$$

$$KD = 144$$

$$KI = 2$$

$$PL = 0.75$$

$$T = 0.001 \text{ s}$$

the digital filter coefficients are

$$K = 160$$

$$A = 0.9$$

$$C = 1$$

$$a = 250 \text{ rad/s}$$

and the equivalent continuous filter, G(s), is

$$G(s) = [16 + 0.144s + 1000/s] * 250 / (s+250)$$

The notch filter has two complex zeros, Z and z, and two complex poles, P and p.

The effect of the notch filter is to cancel the resonance affect by placing the complex zeros on top of the resonance poles. The notch poles, P and p, are programmable and are selected to have sufficient damping. It is best to select

the notch parameters by the frequency terms. The poles and zeros have a frequency in Hz, selected by the command NF. The real part of the poles is set by NB and the real part of the zeros is set by NZ.

The most simple procedure for setting the notch filter, identify the resonance frequency and set NF to the same value. Set NB to about one half of NF and set NZ to a low value between zero and 5.

ZOH

The ZOH, or zero-order-hold, represents the effect of the sampling process, where the motor command is updated once per sampling period. The effect of the ZOH can be modeled by the transfer function

$$H(s) = 1/(1+sT/2)$$

If the sampling period is $T = 0.001$, for example, $H(s)$ becomes:

$$H(s) = 2000/(s+2000)$$

However, in most applications, $H(s)$ may be approximated as one.

This completes the modeling of the system elements. Next, we discuss the system analysis.

System Analysis

To analyze the system, we start with a block diagram model of the system elements. The analysis procedure is illustrated in terms of the following example.

Consider a position control system with the DMC-40x0 controller and the following parameters:

$K_t = 0.1$	Nm/A	Torque constant
$J = 2.10^{-4}$	kg.m ²	System moment of inertia
$R = 2$	Ω	Motor resistance
$K_a = 4$	Amp/Volt	Current amplifier gain
$K_P = 12.5$		Digital filter gain
$K_D = 245$		Digital filter zero
$K_I = 0$		No integrator
$N = 500$	Counts/rev	Encoder line density
$T = 1$	ms	Sample period

The transfer function of the system elements are:

Motor

$$M(s) = P/I = K_t/Js^2 = 500/s^2 \text{ [rad/A]}$$

Amp

$$K_a = 4 \text{ [Amp/V]}$$

DAC

$$K_d = 0.0003 \text{ [V/count]}$$

Encoder

$$K_f = 4N/2\pi = 318 \text{ [count/rad]}$$

ZOH

$$2000/(s+2000)$$

Digital Filter

$$K_P = 12.5, K_D = 245, T = 0.001$$

Therefore,

$$D(z) = 1030 (z-0.95)/Z$$

Accordingly, the coefficients of the continuous filter are:

$$P = 50$$

$$D = 0.98$$

The filter equation may be written in the continuous equivalent form:

$$G(s) = 50 + 0.98s = .098 (s+51)$$

The system elements are shown in Fig. 10.7.

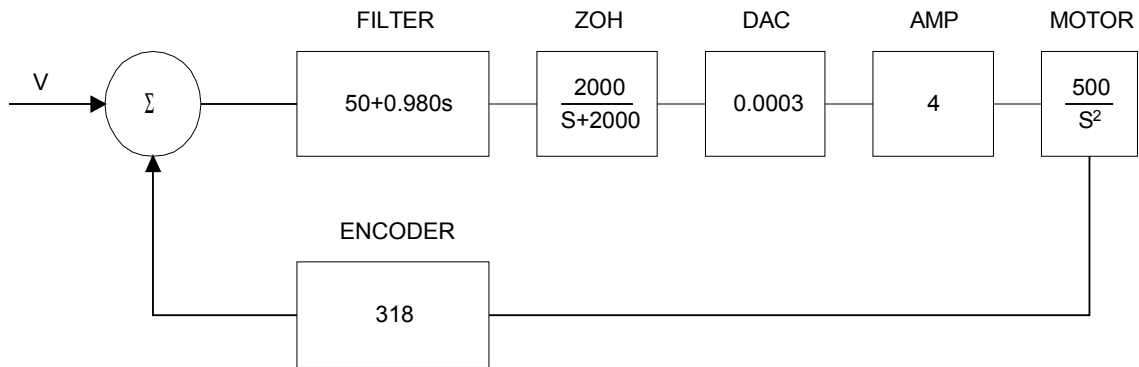

Figure 10.7 - Mathematical model of the control system

The open loop transfer function, $A(s)$, is the product of all the elements in the loop.

$$A = 390,000 (s+51)/[s^2(s+2000)]$$

To analyze the system stability, determine the crossover frequency, ω_c at which $A(j\omega_c)$ equals one. This can be done by the Bode plot of $A(j\omega_c)$, as shown in Fig. 10.8.

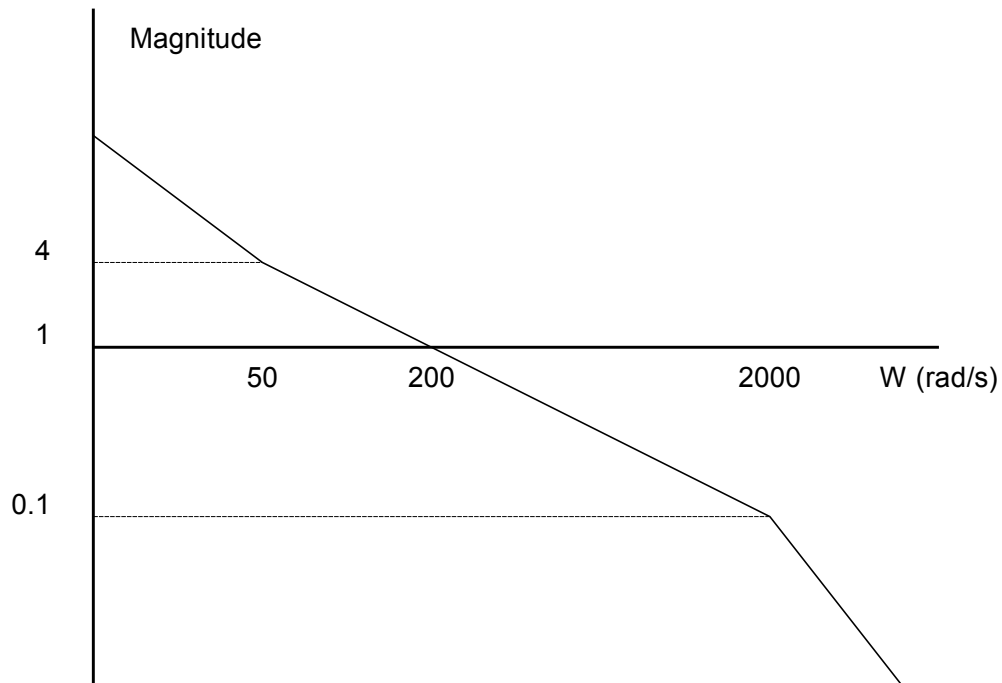

Figure 10.8 - Bode plot of the open loop transfer function

For the given example, the crossover frequency was computed numerically resulting in 200 rad/s.

Next, we determine the phase of A(s) at the crossover frequency.

$$A(j200) = 390,000 (j200+51)/[(j200)^2 \cdot (j200 + 2000)]$$

$$\alpha = \text{Arg}[A(j200)] = \tan^{-1}(200/51) - 180^\circ - \tan^{-1}(200/2000)$$

$$\alpha = 76^\circ - 180^\circ - 6^\circ = -110^\circ$$

Finally, the phase margin, PM, equals

$$\text{PM} = 180^\circ + \alpha = 70^\circ$$

As long as PM is positive, the system is stable. However, for a well damped system, PM should be between 30 degrees and 45 degrees. The phase margin of 70 degrees given above indicated overdamped response.

Next, we discuss the design of control systems.

System Design and Compensation

The closed-loop control system can be stabilized by a digital filter, which is preprogrammed in the DMC-40x0 controller. The filter parameters can be selected by the user for the best compensation. The following discussion presents an analytical design method.

The Analytical Method

The analytical design method is aimed at closing the loop at a crossover frequency, ω_c , with a phase margin PM. The system parameters are assumed known. The design procedure is best illustrated by a design example.

Consider a system with the following parameters:

K_t	Nm/A	Torque constant
$J = 2.10^{-4}$	kg.m ²	System moment of inertia
$R = 2$	Ω	Motor resistance
$K_a = 2$	Amp/Volt	Current amplifier gain
$N = 1000$	Counts/rev	Encoder line density

The DAC of the DMC-40x0 outputs +/-10V for a 16-bit command of +/-32768 counts.

The design objective is to select the filter parameters in order to close a position loop with a crossover frequency of $\omega_c = 500$ rad/s and a phase margin of 45 degrees.

The first step is to develop a mathematical model of the system, as discussed in the previous system.

Motor

$$M(s) = P/I = K_t/Js^2 = 1000/s^2$$

Amp

$$K_a = 2 \quad [\text{Amp/V}]$$

DAC

$$K_d = 10/32768 = .0003$$

Encoder

$$K_f = 4N/2\pi = 636$$

ZOH

$$H(s) = 2000/(s+2000)$$

Compensation Filter

$$G(s) = P + sD$$

The next step is to combine all the system elements, with the exception of $G(s)$, into one function, $L(s)$.

$$L(s) = M(s) K_a K_d K_f H(s) = 3.17 \times 10^6 / [s^2(s+2000)]$$

Then the open loop transfer function, $A(s)$, is

$$A(s) = L(s) G(s)$$

Now, determine the magnitude and phase of $L(s)$ at the frequency $\omega_c = 500$.

$$L(j500) = 3.17 \times 10^6 / [(j500)^2 (j500+2000)]$$

This function has a magnitude of

$$|L(j500)| = 0.00625$$

and a phase

$$\text{Arg}[L(j500)] = -180^\circ - \tan^{-1}(500/2000) = -194^\circ$$

$G(s)$ is selected so that $A(s)$ has a crossover frequency of 500 rad/s and a phase margin of 45 degrees. This requires that

$$|A(j500)| = 1$$

$$\text{Arg}[A(j500)] = -135^\circ$$

However, since

$$A(s) = L(s) G(s)$$

then it follows that $G(s)$ must have magnitude of

$$|G(j500)| = |A(j500)/L(j500)| = 160$$

and a phase

$$\text{arg}[G(j500)] = \text{arg}[A(j500)] - \text{arg}[L(j500)] = -135^\circ + 194^\circ = 59^\circ$$

In other words, we need to select a filter function $G(s)$ of the form

$$G(s) = P + sD$$

so that at the frequency $\omega_c = 500$, the function would have a magnitude of 160 and a phase lead of 59 degrees.

These requirements may be expressed as:

$$|G(j500)| = |P + (j500D)| = 160$$

and

$$\text{arg}[G(j500)] = \tan^{-1}[500D/P] = 59^\circ$$

The solution of these equations leads to:

$$P = 160 \cos 59^\circ = 82.4$$

$$500D = 160 \sin 59^\circ = 137$$

Therefore,

$$D = 0.274$$

and

$$G = 82.4 + 0.2744s$$

The function G is equivalent to a digital filter of the form:

$$D(z) = KP + KD(1-z^{-1})$$

where

$$P = KP$$

$$D = KD * T$$

and

$$KD = D/T$$

Assuming a sampling period of $T=1\text{ms}$, the parameters of the digital filter are:

$$KP = 82.4$$

$$KD = 247.4$$

The DMC-40x0 can be programmed with the instruction:

$$KP \ 82.4$$

$$KD \ 68.6$$

In a similar manner, other filters can be programmed. The procedure is simplified by the following table, which summarizes the relationship between the various filters.

Equivalent Filter Form - DMC-40x0

Digital	$D(z) = [K(z-A/z) + Cz/(z-1)] * (1-B)/(Z-B)$
---------	--

Digital	$D(z) = [KP + KD(1-z^{-1}) + KI/2(1-z^{-1})] * (1-B)/(Z-B)$
---------	---

KP, KD, KI, PL	$K = (KP + KD)$
----------------	-----------------

$$A = KD/(KP+KD)$$

$$C = KI/2$$

$$B = PL$$

Continuous	$G(s) = (P + Ds + I/s) * a/s+a$
------------	---------------------------------

PID, T	$P = KP$
--------	----------

$$D = T * KD$$

$$I = KI / 2T$$

$$a = 1/T \ln(1/PL)$$

THIS PAGE LEFT BLANK INTENTIONALLY

Appendices

Electrical Specifications

Servo Control

MCMn Amplifier Command:	+/-10 volt analog signal. Resolution 16-bit DAC or 0.0003 volts. 3 mA maximum. Output impedance – 500Ω
MA+,MA-,MB+,MB-,MI+,MI- Encoder and Auxiliary	TTL compatible, but can accept up to +/-12 volts. Quadrature phase on CHA, CHB. Can accept single-ended (A+,B+ only) or differential (A+,A-,B+,B-). Maximum A, B edge rate: 22 MHz. Minimum IDX pulse width: 45 nsec.

Stepper Control

STPn (Step)	TTL (0-5 volts) level at 50% duty cycle. 6,000,000 pulses/sec maximum frequency
DIRn (Direction)	TTL (0-5 volts)

Input / Output

Limit Switch Inputs, Home Inputs. DI1 thru DI8 Uncommitted Inputs and Abort Input DI9 thru DI16 Uncommitted Inputs (DMC-4050 through DMC-4080 only)	2.2K ohm in series with opto-isolator. Active high or low requires at least 1mA to activate. Once activated, the input requires the current to go below 0.5ma. All Limit Switch and Home inputs use one common voltage (LSCOM) which can accept up to 24 volts. Voltages above 24 volts require an additional resistor. $\geq 1 \text{ mA} = \text{ON}; \leq 0.5 \text{ mA} = \text{OFF}$
AI1 thru AI8 Analog Inputs:	Standard configuration is +/-10 volts. 12-Bit Analog-to-Digital converter. 16-bit optional.
DO1 thru DO8 Outputs:	High power Opto-Isolated – 500mA sourcing
DO9 thru DO16 Outputs: (DMC-4050 through DMC-4080 only)	High power Opto-Isolated – 500mA sourcing

IO17 thru IO48	Extended configurable I/O Standard 3.3V logic with 5V option
DI81, DI82	Auxiliary Encoder Inputs for A (X) axis. Line Receiver Inputs - accepts differential or single ended voltages with voltage range of +/- 12 volts.
DI83, DI84 (DMC-4020 through DMC-4080 only)	Auxiliary Encoder Inputs for B (Y) axis. Line Receiver Inputs - accepts differential or single ended voltages with voltage range of +/- 12 volts.
DI85, DI86 (DMC-4030 through DMC-4080 only)	Auxiliary Encoder Inputs for C (Z) axis. Line Receiver Inputs - accepts differential or single ended voltages with voltage range of +/- 12 volts.
DI87, DI88 (DMC-4040 through DMC-4080 only)	Auxiliary Encoder Inputs for D (W) axis. Line Receiver Inputs - accepts differential or single ended voltages with voltage range of +/- 12 volts.
DI89, DI90 (DMC-4050 through DMC-4080 only)	Auxiliary Encoder Inputs for E axis. Line Receiver Inputs - accepts differential or single ended voltages with voltage range of +/- 12 volts.
DI91, DI92 (DMC-4060 through DMC-4080 only)	Auxiliary Encoder Inputs for F axis. Line Receiver Inputs - accepts differential or single ended voltages with voltage range of +/- 12 volts.
DI93, DI94 (DMC-4070 through DMC-4080 only)	Auxiliary Encoder Inputs for G axis. Line Receiver Inputs - accepts differential or single ended voltages with voltage range of +/- 12 volts.
DI95, DI96 (DMC-4080 only)	Auxiliary Encoder Inputs for H axis. Line Receiver Inputs - accepts differential or single ended voltages with voltage range of +/- 12 volts.

Power Requirements

20-80 VDC 12-16W at 25C

+5, +/-12V Power Output Specifications

Output Voltage	Tolerance	Max Current Output
+5V	+/-5%	1.1A
+12V	+/-5%	40mA
-12V	+/-5%	40mA

Performance Specifications

Minimum Servo Loop Update Time:

	Normal	Fast Firmware
Minimum Servo Loop Update Time:		
DMC-4010	62.5 μ sec	31.25 μ sec
DMC-4020	62.5 μ sec	31.25 μ sec
DMC-4030	125 μ sec	62.5 μ sec
DMC-4040	125 μ sec	62.5 μ sec
DMC-4050	156.25 μ sec	93.75 μ sec
DMC-4060	156.25 μ sec	93.75 μ sec
DMC-4070	187.5 μ sec	125 μ sec
DMC-4080	187.5 μ sec	125 μ sec
Position Accuracy:	+/-1 quadrature count	
Velocity Accuracy:		
Long Term	Phase-locked, better than 0.005%	
Short Term	System dependent	
Position Range:	+/-2147483647 counts per move	
Velocity Range:	Up to 22,000,000 counts/sec servo; 6,000,000 pulses/sec-stepper	
Velocity Resolution:	2 counts/sec	
Motor Command Resolution:	16 bit or 0.0003 V	
Variable Range:	+/-2 billion	
Variable Resolution:	1 · 10 ⁻⁴	
Array Size:	16000 elements, 30 arrays	
Program Size:	2000 lines x 80 characters	

Fast Update Rate Mode

The DMC-40x0 can operate with much faster servo update rates than the default of every millisecond. This mode is known as 'fast mode' and allows the controller to operate with the following update rates:

DMC-4010	31.25 μ sec
DMC-4020	31.25 μ sec
DMC-4030	62.5 μ sec
DMC-4040	62.5 μ sec
DMC-4050	93.75 μ sec
DMC-4060	93.75 μ sec
DMC-4070	125 μ sec
DMC-4080	125 μ sec

In order to run the DMC-40x0 motion controller in fast mode, the fast firmware must be uploaded. This can be done through the GalilTools communication software. The fast firmware is included with the original DMC-40x0 utilities.

In order to set the desired update rates, use the command TM.

When the controller is operating with the fast firmware, the following functions are **disabled**:

- Gearing mode
- Ecam mode
- Pole (PL)
- Analog Feedback (AF)
- Stepper Motor Operation (MT 2,-2,2.5,-2.5)
- Trippoints in thread 2-8
- Tell Velocity Interrogation Command (TV)
- Aux Encoders (TD)
- Dual Velocity (DV)
- Peak Torque Limit (TK)
- Notch Filter (NB, NF, NZ)

Ordering Options for the DMC-40x0

Overview

The DMC-40x0 can be ordered in many different configurations and with different options. This section provides information regarding the different options available on the DMC-40x0 motion controller, interconnect modules and internal amplifiers. For information on how to order a controller with these options, see our DMC-40x0 part number generator on our website.

<http://www.galilmc.com/products/dmc-40x0-part-number.php>

DMC-40x0 Controller Board Options

DIN – DIN Rail Mounting

The DIN option on the DMC-40x0 motion controller provides DIN rail mounts on the base of the controller. This will allow the controller to be mounted to any standard DIN rail.

Part number ordering example: DMC-4010(DIN)-C012-I000

12V – Power Controller with 12VDC

The 12V option allows the controller to be powered with a regulated 12V supply. In most cases, this option is only appropriate if no Galil amplifiers are used.

Part number ordering example: DMC-4010(12V)-C012-I000

TRES – Encoder Termination Resistors

The TRES option provides termination resistors on all of the main and auxiliary encoder inputs on the DMC-40x0 motion controller. The termination resistors are 120 Ohm, and are placed between the positive and negative differential inputs on the Main A, B, Index channels as well as the Auxiliary A and B channels as shown below.

Note: Single ended encoders will not operate correctly with the termination resistors installed. If a combination of differential encoder inputs with termination resistors and single ended encoders is required on the same interconnect module is required, contact Galil directly.

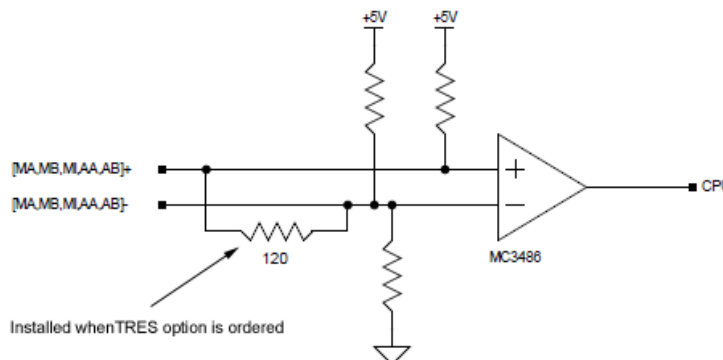

Part number ordering example: DMC-4010(TRES)-C012-I000

-16 bit – 16 bit Analog Inputs

The -16 bit option provides 16 bit analog inputs on the DMC-40x0 motion controller. The standard resolution of the analog inputs is 12 bits.

Part number ordering example: DMC-4010(-16bit)-C012-I000

ISCNTL – Isolate Controller Power

The ISCNTL option isolates the power input for the controller from the power input of the amplifiers. With this option, the power is brought in through the 2 pin Molex connector on the side of the controller as shown in the [DMC-40x0 Power Connections](#) section in Chapter 2. This option is not valid when Galil amplifiers are not ordered with the DMC-40x0.

Part number ordering example: DMC-4010(ISCNTL)-C012-I000

ETL – ETL Certified DMC-40x0

The DMC-40x0 can be ordered in a configuration that is ETL listed.

Part number ordering example: DMC-4010(ETL)-C012-I000

CMB Communication Board Options

5V – Configure Extended I/O for 5V logic

The 5V option for the CMB-41012 configures the 32 configurable extended I/O for 5V logic. The standard configuration for the extended I/O is 3.3V. For more information see the [Extended I/O of the DMC-40x0 Controller](#) section in Chapter 3.

Part number ordering example: DMC-4010-C012(5V)-I000

RS-232/RS-422 – Serial Port Serial Communication

The default serial configuration for the DMC-40x0 is to have RS-232 communication on both the Main (P1) and Aux (P2) serial ports. The controller can be ordered to have RS-422 on the Main, Aux or both serial ports.

Part number ordering example: DMC-4010-C012(P422)-I000

ICM Interconnect Board Options

SSI – SSI encoder Option

The SSI option configures the ICM interconnect module for SSI encoder inputs. For more information on the SSI implementation, see [Application Note # 2438: Galil SSI Encoder Interface](#).

Note: This option is not valid with the ICM-42100 (-I100). Consult Galil if the Sinusoidal encoder and SSI encoder interfaces are required on the same set of 4 axes.

Part number ordering example: DMC-4010-C012-I000(SSI)

DIFF – Differential analog motor command outputs

The DIFF option configures the ICM interconnect module with differential analog motor command outputs. Single-ended motor command outputs are standard. See the individual ICM sections in Integrated Components for pinout information.

Part number ordering example: DMC-4010-C012-I000(DIFF)

STEP – Differential step and direction outputs

The STEP option configures the ICM interconnect module with differential step and direction outputs. Single-ended step and direction outputs are standard. See the individual ICM sections in [Integrated Components](#) for pinout information.

Part number ordering example: DMC-4010-C012-I000(STEP)

Amplifier Enable Configurations

The default amplifier enable configuration for the ICM interconnect modules is 5V, HAEN, SINK. This is 5V logic, high amplifier enable, and sinking. The amplifier enable configuration can be configured at the factory or in the field. It is recommended that the correct amplifier enable configuration be ordered from the factory when using the ICM-42000 (-I000) or the ICM-42100 (-I100). The Galil internal amplifiers will work with any amplifier enable configurations set on the interconnect module.

See the [Amplifier Interface](#) section in Chapter 3 for more information.

Part number ordering example: DMC-4010-C012-I000(24V,HAEN,SINK)

5V – 5V Amplifier Enable Voltage

Uses the DMC-40x0 internal 5V for the amplifier enable circuit.

12V – 12V Amplifier Enable Voltage

Uses the DMC-40x0 internal 12V for the amplifier enable circuit.

24V – 24V Amplifier Enable Voltage

ICM is configured to be run from an external power supply of 13 -24VDC.

LAEN – Low Amplifier Enable

The controller sets the amplifier enable signal to logic low to enable the drive.

HAEN – High Amplifier Enable

The controller sets the amplifier enable signal to logic high to enable the drive.

SINK – Sinking Amplifier Enable

The amplifier will sink to controller ground with 5V and 12V options or to external supply ground when 24V is ordered.

Source – Sourcing Amplifier Enable

The amplifier will source the internal 5V, 12V or the external 13-24V DC supply.

AMP Internal Amplifier Options

ISAMP – Isolation of power between each AMP amplifier

The ISAMP option separates the power pass-through between the Axes 1-4 amplifier and the Axes 5-8 amplifier. This allows the 2 internal amplifiers to be powered at separate voltages.

If the ISCNTL option is NOT ordered on the DMC-40x0, the amplifier with the higher bus voltage will automatically power the controller. The amplifier with the higher voltage, and the voltage level does not have to be specified during time of purchase as long as the voltage falls within the range of 20-80VDC.

This option is only valid on the 5-8 Axes amplifier board.

Part number ordering example: DMC-4080-C012-I000-I000-D3040-D3040(ISAMP)

100mA – 100mA Maximum Current output for AMP-43140

The 100mA option configures the AMP-43140 (-D3140) for 10mA/V gain with a maximum current output of 100mA.

This option is only valid with the AMP-43140.

Part number ordering example: DMC-4040-C012-I000-D3140(100mA)

SSR – Solid State Relay Option for AMP-43140

The SSR option configures the AMP-43140 (-D3140) with Solid State Relays on the motor power leads that are engaged and disengaged when the amplifier is enabled and disabled. See the [-SSR Option](#) in the AMP-43140 section of the Appendix for more information.

This option is only valid with the AMP-43140.

Part number ordering example: DMC-4040-C012-I000-D3140(SSR)

Power Connectors for the DMC-40x0

Overview

The DMC-40x0 uses Molex Pitch Mini-Fit, Jr.™ Receptacle Housing connectors for connecting DC Power to the Amplifiers, Controller, and Motors. This section gives the specifications of these connectors. For information specific to your Galil amplifier or driver, refer to the specific amplifier/driver in the [Integrated Components](#) section.

Molex Part Numbers Used

There are 3 different Molex connectors used with the DMC-40x0. The type of connectors on any given controller will be determined by the Amplifiers/Drivers that were ordered. Below are tables indicating the type of Molex Connectors used and the specific part numbers used on each Amplifier or Driver. For more information on the connectors, go to <http://www.molex.com/>.

Note: These part number list the connectors that are found on the controller. For more information see the Molex Website.

Molex Part Number	Crimp Part Number	Type
39-31-0060	44476-3112	6 Position
39-31-0040	44476-3112	4 Position
39-31-0020	44476-3112	2 Position

Galil Amplifier / Driver		Molex Part Number	Type
None		39-31-0020	2 Position
AMP-43040	Power	39-31-0060	6 Position
	Motor	39-31-0040	4 Position
AMP-43140	Power	39-31-0040	4 Position
	Motor	39-31-0020	2 Position
SDM-44040	Power	39-31-0060	6 Position
	Motor	39-31-0040	4 Position
SMD-44140	Power	39-31-0060	6 Position
	Motor	39-31-0040	4 Position

Cable Connections for DMC-40x0

The DMC-40x0 requires the transmit, receive, and ground for slow communication rates. (i.e. 9600 baud) For faster rates the handshake lines are required. The connection tables below contain the handshake lines.

Standard RS-232 Specifications

25 pin Serial Connector (Male, D-type)

This table describes the pinout for standard serial ports found on most computers.

Pin #	Function
1	NC
2	TXD
3	RXD
4	RTS
5	CTS
6	DSR
7	GND
8	DCD
9	NC
10	NC
11	NC
12	NC
13	NC
14	NC
15	NC
16	NC
17	NC
18	NC
19	NC
20	DTR
21	NC
22	RI
23	NC
24	NC
25	NC

9 Pin Serial Connector (Male, D-type)

Standard serial port connections found on most computers.

Pin #	Function
1	DCD
2	RXD
3	TXD
4	RTS
5	GND
6	DSR
7	RTS
8	CTS
9	RI

DMC-40x0 Serial Cable Specifications

Cable to Connect Computer 25 pin to Main Serial Port

25 Pin (Male - computer)	9 Pin (female - controller)
5 CTS	8 RTS
3 RXD	2 TXD
2 TXD	3 RXD
4 RTS	7 CTS
7 GND	5 GND

Cable to Connect Computer 9 pin to Main Serial Port Cable (9 pin)

9 Pin (FEMALE - Computer)	9 Pin (FEMALE - Controller)
2 RXD	2 TXD
3 TXD	3 RXD
5 GND	5 GND
7 RTS	7 CTS
8 CTS	8 RTS

Cable to Connect Computer 25 pin to Auxiliary Serial Port Cable (9 pin)

25 Pin (Male - terminal)	9 Pin (male - controller)
4 RTS	8 CTS
2 TXD	2 RXD
3 RXD	3 TXD
5 CTS	7 RTS
7 GND	5 GND
Computer +5V	9 (Jumper APWR if required)

Cable to Connect Computer 9 pin to Auxiliary Serial Port Cable (9 pin)

9 Pin (FEMALE - terminal)	9 Pin (MALE - Controller)
---------------------------	---------------------------

4 RTS	8 CTS
3 TXD	2 RXD
2 RXD	3 TXD
1 CTS	7 RTS
5 GND	5 GND
Controller +5V	9 (Jumper APWR if required)

Pin-Out Description for DMC-40x0

Outputs

Motor Command	+/- 10 Volt range signal for driving amplifier. In servo mode, motor command output is updated at the controller sample rate. In the motor off mode, this output is held at the OF command level.
Amplifier Enable	Signal to disable and enable an amplifier. Amp Enable goes low on Abort and OE1.
PWM / Step	PWM/STEP OUT is used for directly driving power bridges for DC servo motors or for driving step motor amplifiers. For servo motors: If you are using a conventional amplifier that accepts a +/- 10 Volt analog signal, this pin is not used and should be left open. The PWM output is available in two formats: Inverter and Sign Magnitude. In the Inverter mode, the PWM (64kHz) signal is .2% duty cycle for full negative voltage, 50% for 0 Voltage and 99.8% for full positive voltage (64kHz Switching Frequency). In the Sign Magnitude Mode (MT1.5), the PWM (128 kHz) signal is 0% for 0 Voltage, 99.6% for full voltage and the sign of the Motor Command is available at the sign output (128kHz Switching Frequency).
PWM / Step	For stepper motors: The STEP OUT pin produces a series of pulses for input to a step motor driver. The pulses may either be low or high. The pulse width is 50%.
Sign / Direction	Used with PWM signal to give the sign of the motor command for servo amplifiers or direction for step motors.
Error	The signal goes low when the position error on any axis exceeds the value specified by the error limit command, ER.
Output 1-Output 8 Output 9-Output 16 (DMC-4050 thru 4080)	The high power optically isolated outputs are uncommitted and may be designated by the user to toggle relays and trigger external events. The output lines are toggled by Set Bit, SB, and Clear Bit, CB, instructions. The OP instruction is used to define the state of all the bits of the Output port.

Inputs

Encoder, MA+, MB+	Position feedback from incremental encoder with two channels in quadrature, CHA and CHB. The encoder may be analog or TTL. Any resolution encoder may be used as long as the maximum frequency does not exceed 22,000,000 quadrature states/sec. The controller performs quadrature decoding of the encoder signals resulting in a resolution of quadrature counts (4 x encoder cycles). Note: Encoders that produce outputs in the format of pulses and direction may also be used by inputting the pulses into CHA and direction into Channel B and using the CE command to configure this mode.
Encoder Index, MI+	Once-Per-Revolution encoder pulse. Used in Homing sequence or Find Index command to define home on an encoder index.
Encoder, MA-, MB-, MI-	Differential inputs from encoder. May be input along with CHA, CHB for noise immunity of encoder signals. The CHA- and CHB- inputs are optional.
Auxiliary Encoder, AA+, AB+, Aux A-, Aux B-	Inputs for additional encoder. Used when an encoder on both the motor and the load is required. Not available on axes configured for step motors.
Abort	A low input stops commanded motion instantly without a controlled deceleration. Also aborts motion program.
Reset	A low input resets the state of the processor to its power-on condition. The previously saved state of the controller, along with parameter values, and saved sequences are restored.
Electronic Lock Out	Input that when triggered will shut down the amplifiers at a hardware level. Useful for safety applications where amplifiers must be shut down at a hardware level.
Forward Limit Switch	When active, inhibits motion in forward direction. Also causes execution of limit switch subroutine, #LIMSWI. The polarity of the limit switch may be set with the CN command.
Reverse Limit Switch	When active, inhibits motion in reverse direction. Also causes execution of limit switch subroutine, #LIMSWI. The polarity of the limit switch may be set with the CN command.
Home Switch	Input for Homing (HM) and Find Edge (FE) instructions. Upon BG following HM or FE, the motor accelerates to slew speed. A transition on this input will cause the motor to decelerate to a stop. The polarity of the Home Switch may be set with the CN command.
Input 1 - Input 8 isolated Input 9 - Input 16 isolated	Uncommitted inputs. May be defined by the user to trigger events. Inputs are checked with the Conditional Jump instruction and After Input instruction or Input Interrupt. Input 1 is latch X, Input 2 is latch Y, Input 3 is latch Z and Input 4 is latch W if the high speed position latch function is enabled.
Latch	High speed position latch to capture axis position on occurrence of latch signal. AL command arms latch. Input 1 is latch X, Input 2 is latch Y, Input 3 is latch Z and Input 4 is latch W. Input 9 is latch E, input 10 is latch F, input 11 is latch G, input 12 is latch H.

Configuring the Amplifier Enable Circuit

ICM-42000 and ICM-42100

The following section details the steps needed to change the amplifier enable configuration for the DMC-40x0 controller with an ICM-42000 or ICM-42100. For detailed instruction on changing the amplifier enable configuration on a DMC-40x0 with an ICM-42200 see the section in Chapter 3 labeled ICM-42200 Amplifier Enable Configuration. For electrical details about the amplifier enable circuit, see the ICM-42000 and ICM-42100 Amplifier Enable Circuit section in Chapter 3.

For DMC-4080 refer to DMC-4080 (Steps 1 and 2) section below.

NOTE: From the default configuration, the configuration for +12V High Amp Enable Sinking Configuration does not require the remove of the metal cover. This can be achieved by simply changing the jumpers.

DMC-4040 (Steps 1 and 2)

Step 1: Remove Cover

Notes:

1. Cover Removal:
 - A. Remove Jack Screws (20 Places)
 - B. Remove #6-32x3/16" Button Head Cover Screws (4 Places)
2. Lift Cover Straight Up and Away from Unit.

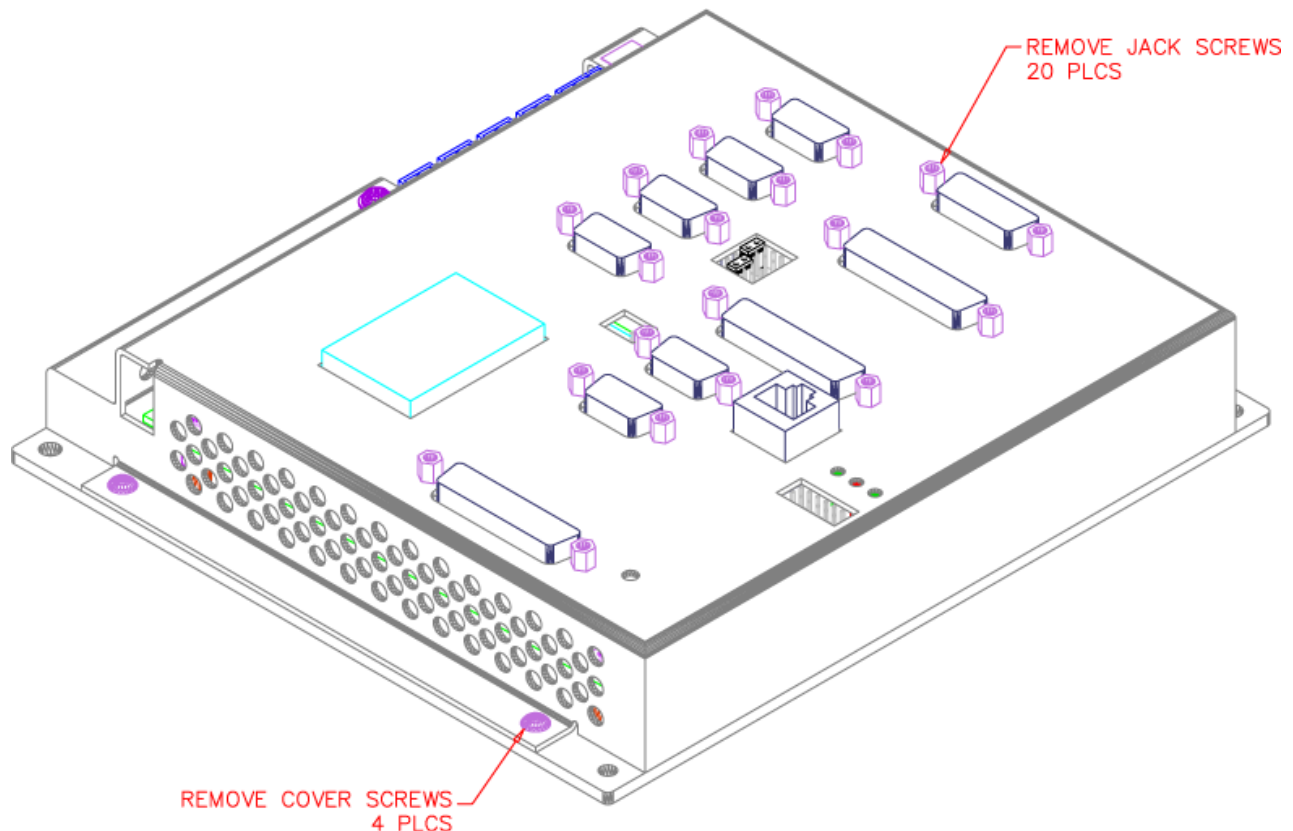

Step 2: Remove ICM

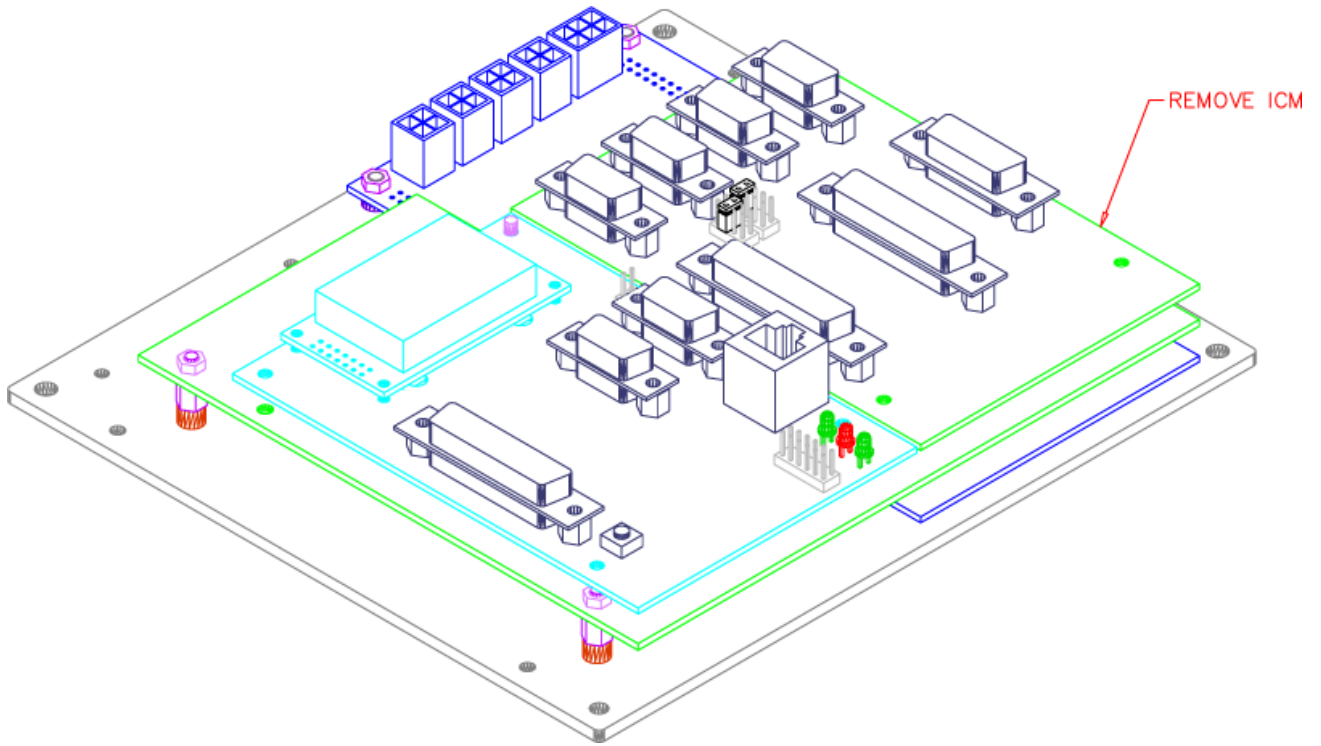

For DMC-4040 – Proceed to Step 3: Configure Circuit

DMC-4080 (Steps 1 and 2)

Step 1: Remove Cover

Notes:

1. Cover Removal:
 - A. Remove Jack Screws (34 Places)
 - B. Remove #6-32x3/16" Button Head Cover Screws (4 Places)
2. Lift Cover Straight Up and Away from Unit.

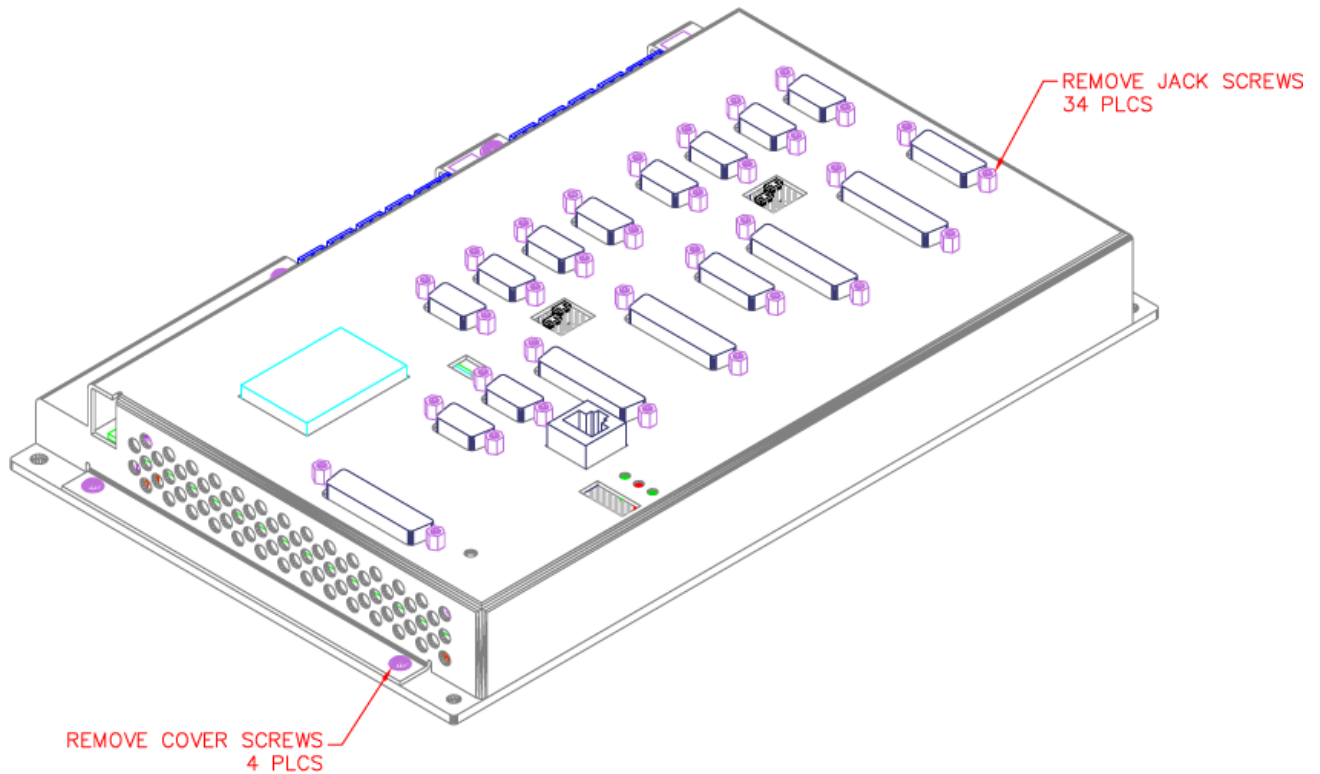

Step 2: Remove ICM(s)

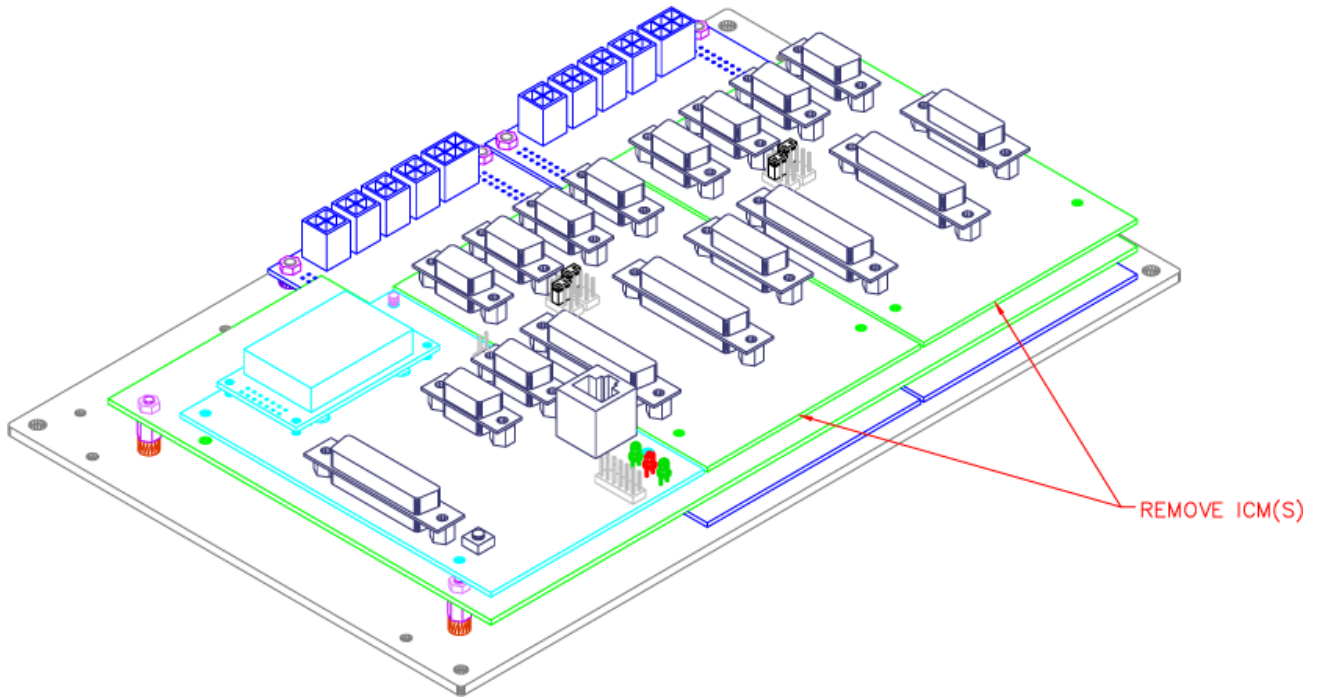

DMC-4040 and DMC-4080 (Step 3)

Step 3: Configure Circuit

Reference the instructions below for the desired configuration, and then proceed to Step 4.

- [+5V High Amp Enable Sinking Configuration \(Default\)](#) pg 217
- [+5V Low Amp Enable Sinking Configuration](#) pg 217
- [+5V High Amp Enable Sourcing Configuration](#) pg 218
- [+5V Low Amp Enable Sourcing Configuration](#) pg 218
- [+12V High Amp Enable Sinking Configuration](#) pg 219
- [+12V Low Amp Enable Sinking Configuration](#) pg 219
- [+12V High Amp Enable Sourcing Configuration](#) pg 220
- [+12V Low Amp Enable Sourcing Configuration](#) pg 220
- [Isolated Power High Amp Enable Sinking Configuration](#) pg 221
- [Isolated Power Low Amp Enable Sinking Configuration](#) pg 221
- [Isolated Power High Amp Enable Sourcing Configuration](#) pg 222
- [Isolated Power Low Amp Enable Sourcing Configuration](#) pg 222

+5V High Amp Enable Sinking Configuration (Default)

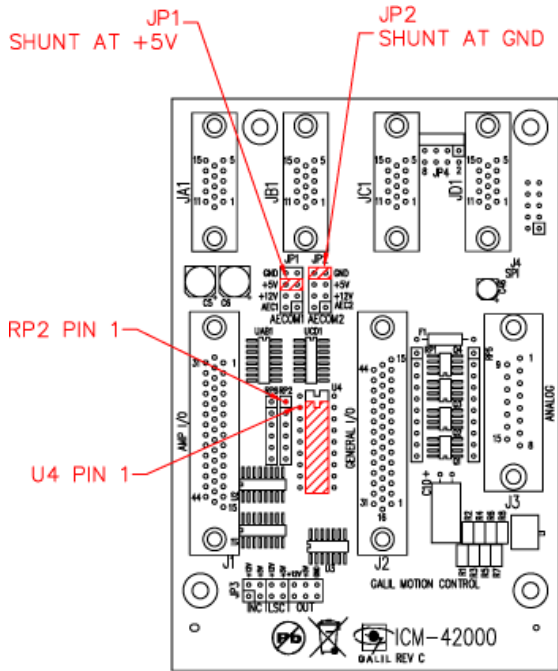

Default Configuration Shipped with controller when no specific setup is ordered.

+5V Low Amp Enable Sinking Configuration

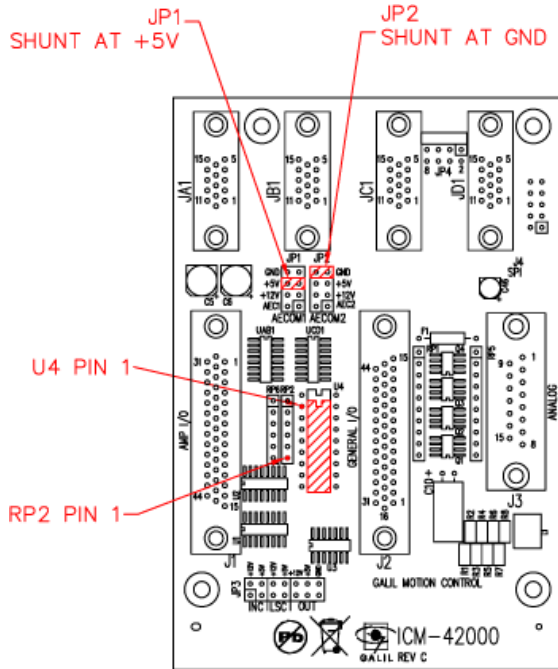

From Default Configuration:

1. Reverse RP2

+5V High Amp Enable Sourcing Configuration

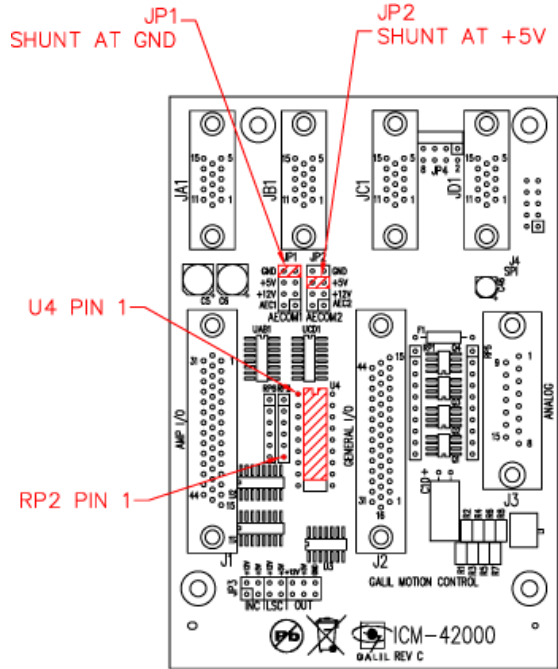

From Default Configuration:

1. Move U4 up one pin location on socket
2. Reverse RP2
3. Change JP1 to GND
4. Change JP2 to +5V

+5V Low Amp Enable Sourcing Configuration

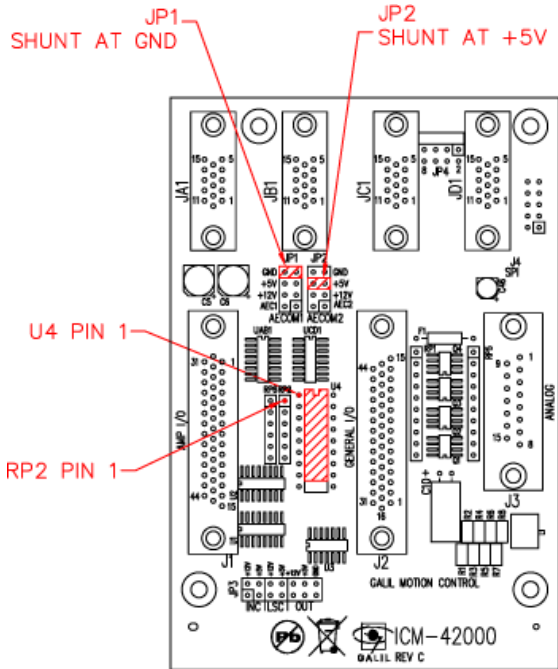

From Default Configuration:

1. Move U4 up one pin location on socket
2. Change JP1 to GND
3. Change JP2 to +5V

+12V High Amp Enable Sinking Configuration

(Does not require the removal of Metal)

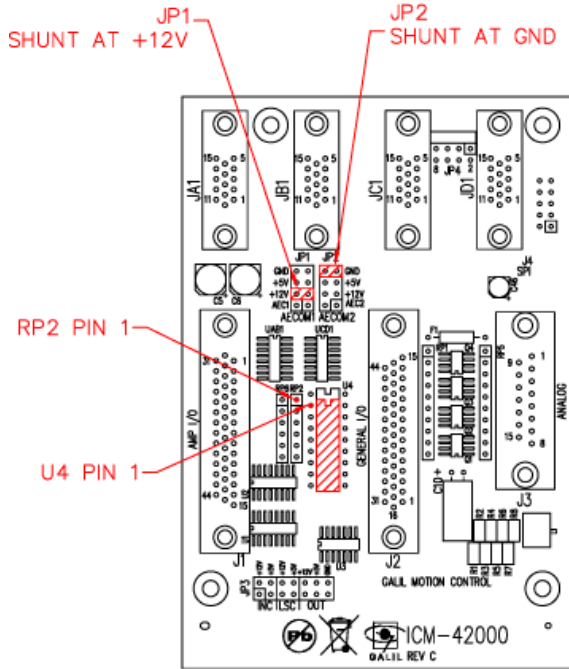

From Default Configuration:

1. Change JP1 to +12V

+12V Low Amp Enable Sinking Configuration

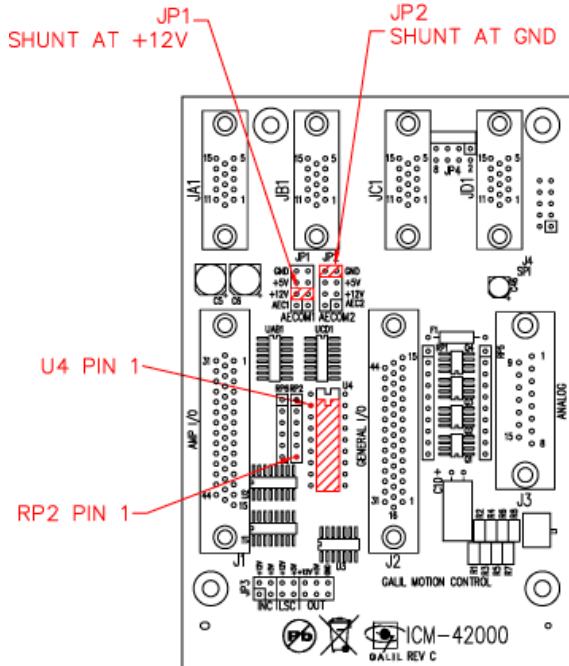

From Default Configuration:

1. Reverse RP2
2. Change JP1 to +12V

+12V High Amp Enable Sourcing Configuration

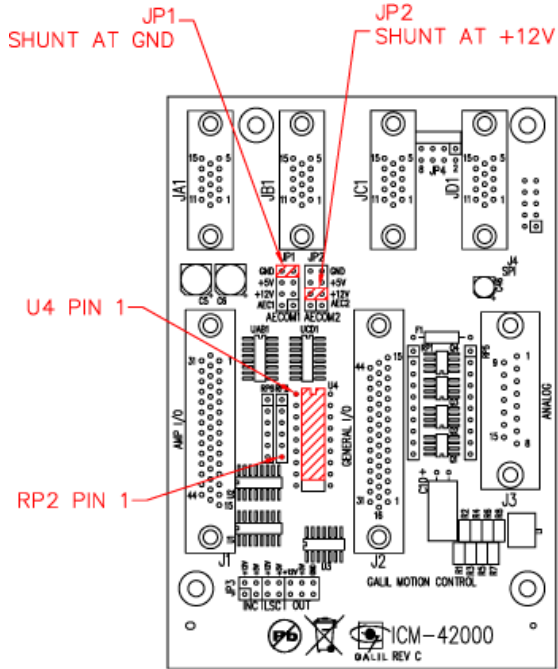

From Default Configuration:

1. Move U4 up one pin location on socket
2. Reverse RP2
3. Change JP1 to GND
4. Change JP2 to +12V

+12V Low Amp Enable Sourcing Configuration

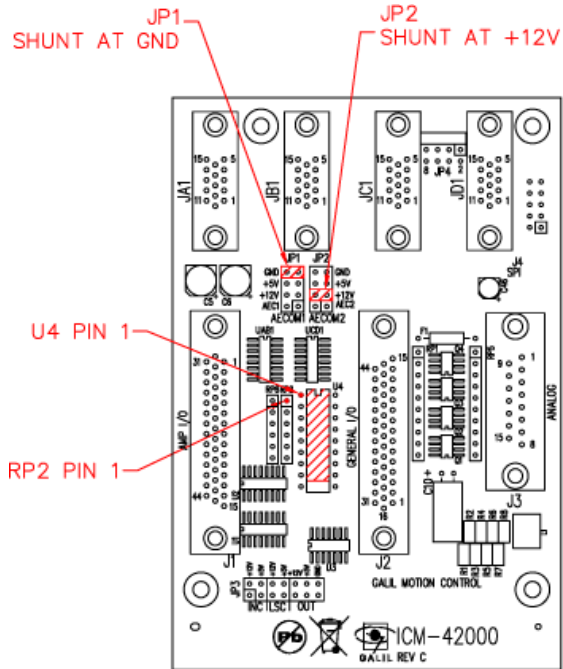

From Default Configuration:

1. Move U4 up one pin location on socket
2. Change JP1 to GND
3. Change JP2 to +12V

Isolated Power High Amp Enable Sourcing Configuration

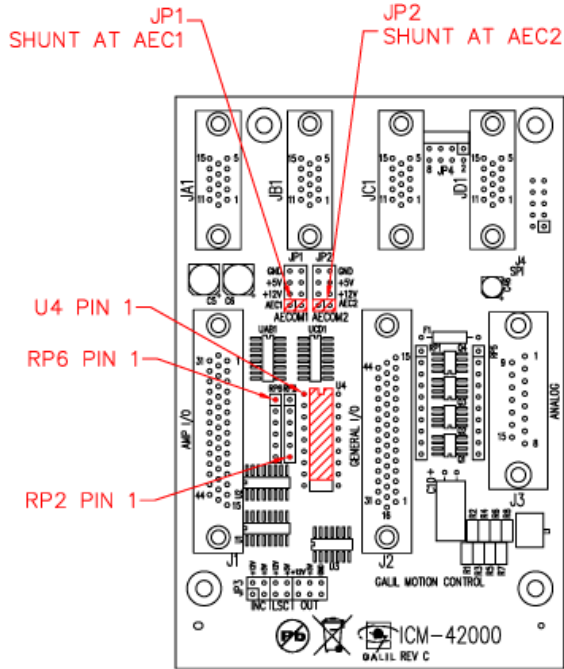

AEC1 = V-
 AEC2 = V+
 For +5V to +12V, RP6 = 820 Ohms
 For +13V to +24V, RP6 = 4.7K Ohms

From Default Configuration:

1. Move U4 up one pin location on socket
2. Reverse RP2
3. Change JP1 to AEC1
4. Change JP2 to AEC2
5. If AEC2 is +13V to +24V, Replace RP6 with 4.7K Resistor Pack

Isolated Power Low Amp Enable Sourcing Configuration

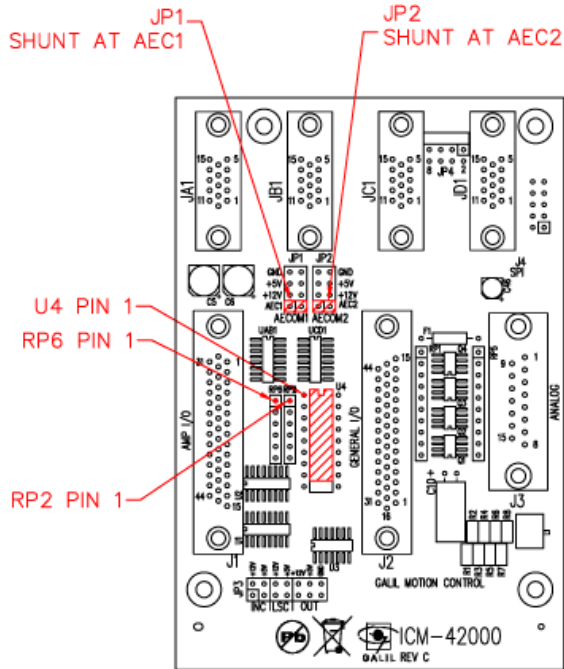

AEC1 = V-
 AEC2 = V+
 For +5V to +12V, RP6 = 820 Ohms
 For +13V to +24V, RP6 = 4.7K Ohms

From Default Configuration:

1. Move U4 up one pin location on socket
2. Change JP1 to AEC1
3. Change JP2 to AEC2
4. If AEC2 is +13V to +24V, Replace RP6 with 4.7K Resistor Pack

For Steps 4 and 5 with a DMC-4080 refer to DMC-4080 (Steps 4 and 5) section below.

DMC-4040 (Steps 4 and 5)

Step 4: Replace ICM

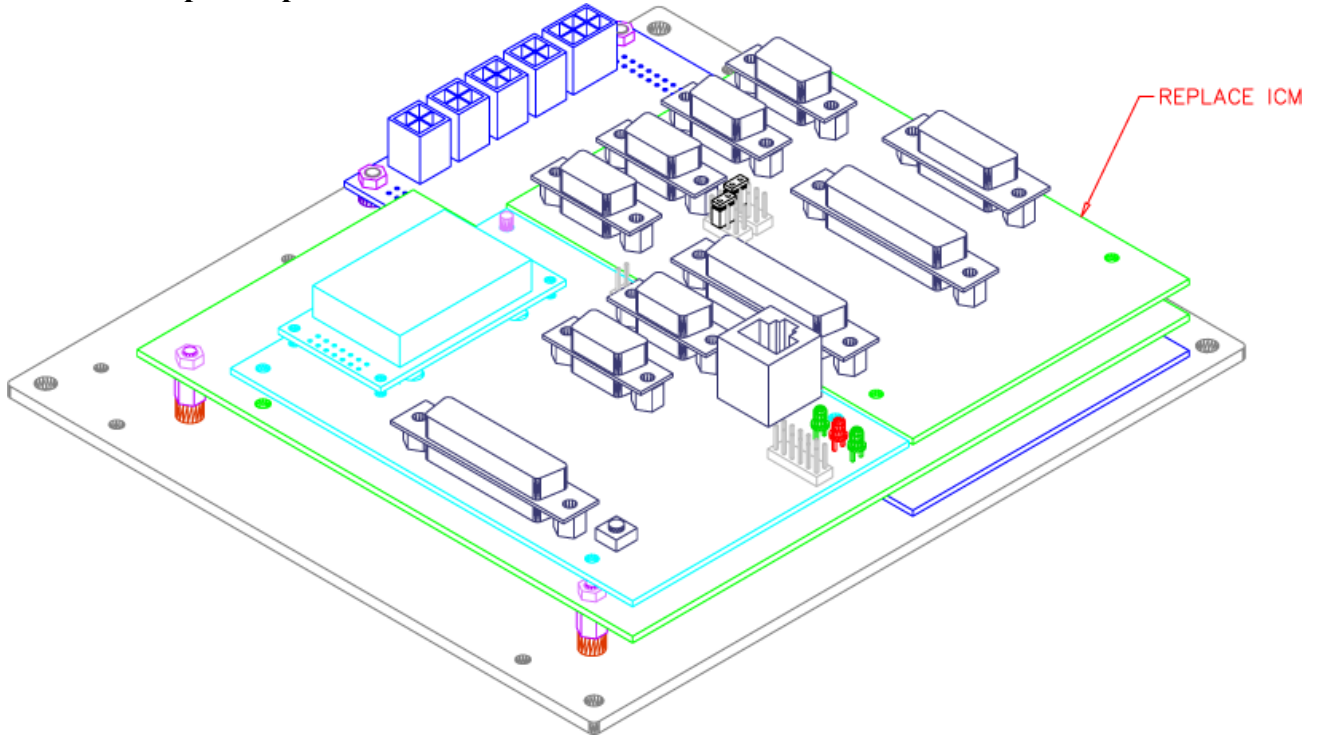

Step 5: Replace Cover

Notes:

1. Cover Installation:
 - A. Install Jack Screws (20 Places)
 - B. Install #6-32x3/16" Button Head Cover Screws(4 Places)

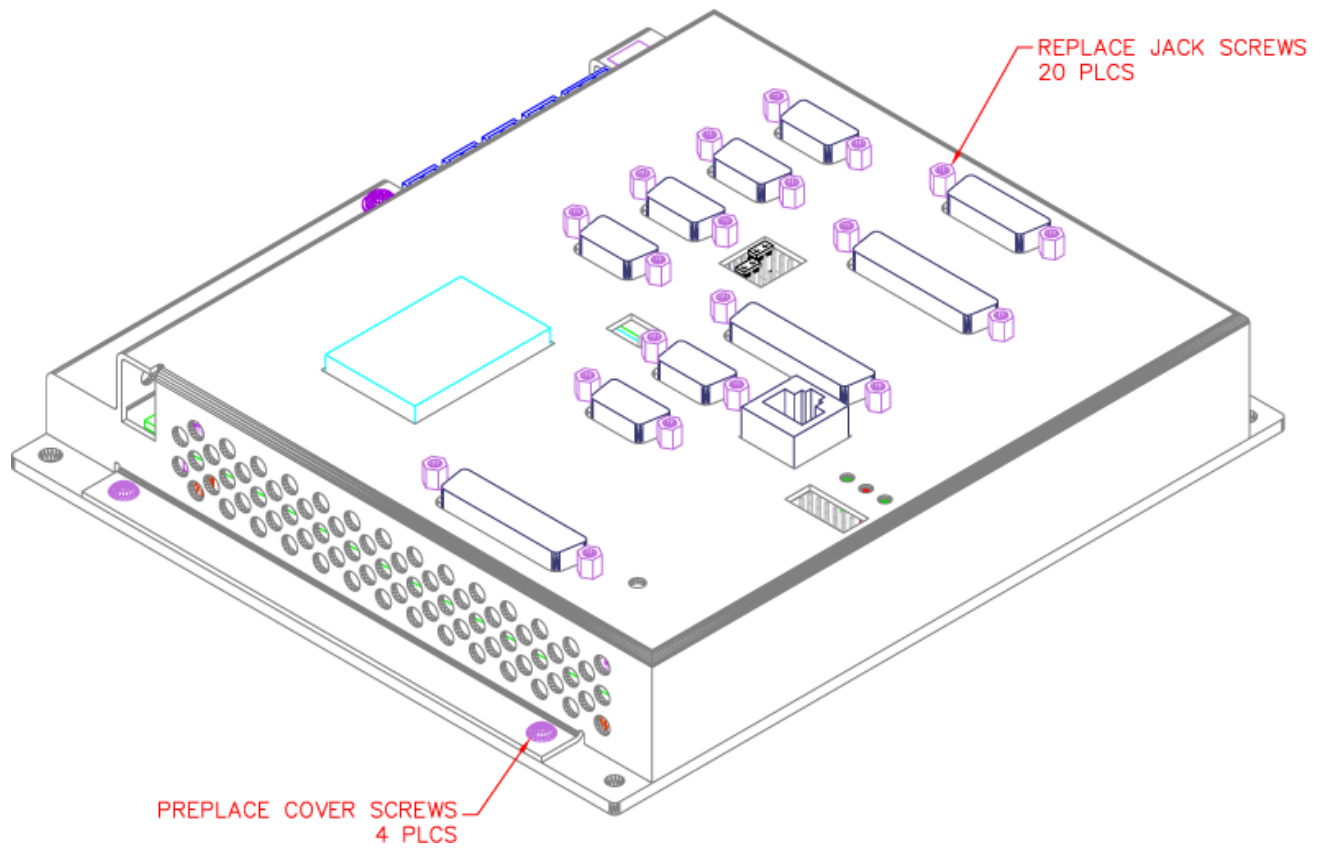

DMC-4080 (Steps 4 and 5)

Step 4: Replace ICM(s)

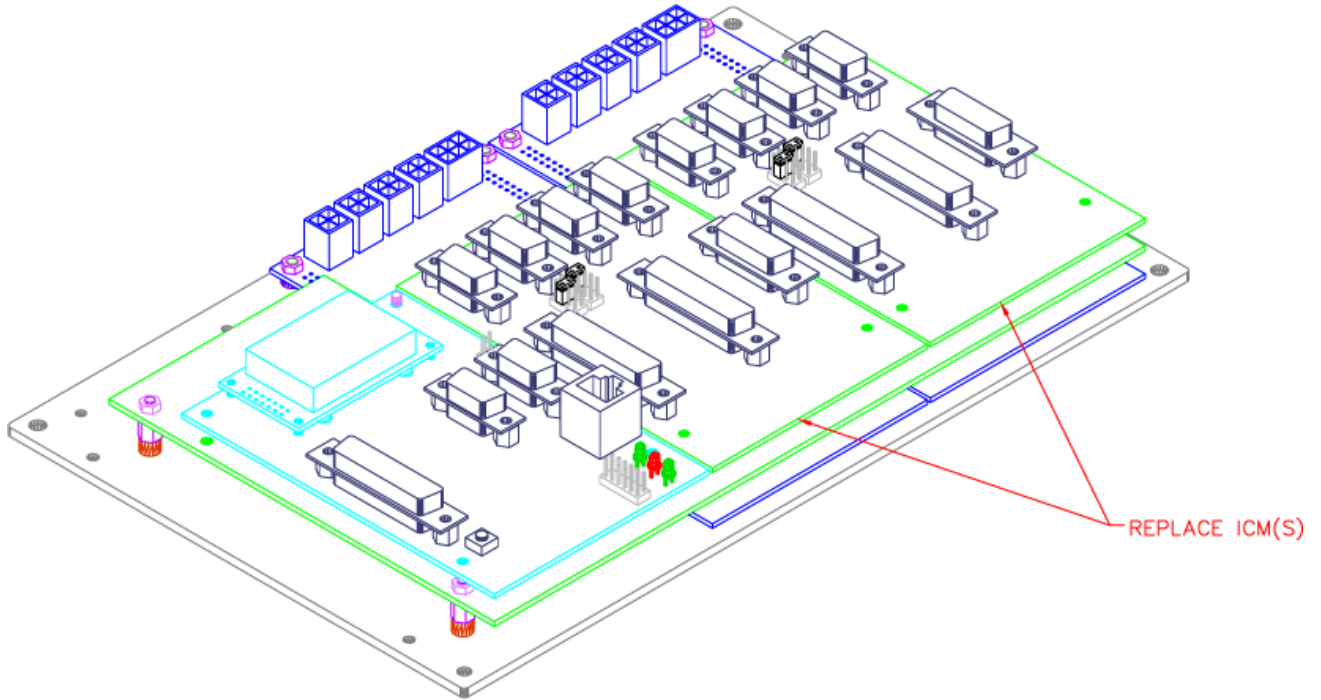

Step 5: Replace Cover

Notes:

1. Cover Installation:
 - A. Install Jack Screws (34 Places)
 - B. Install #6-32x3/16" Button Head Cover Screws(4 Places)

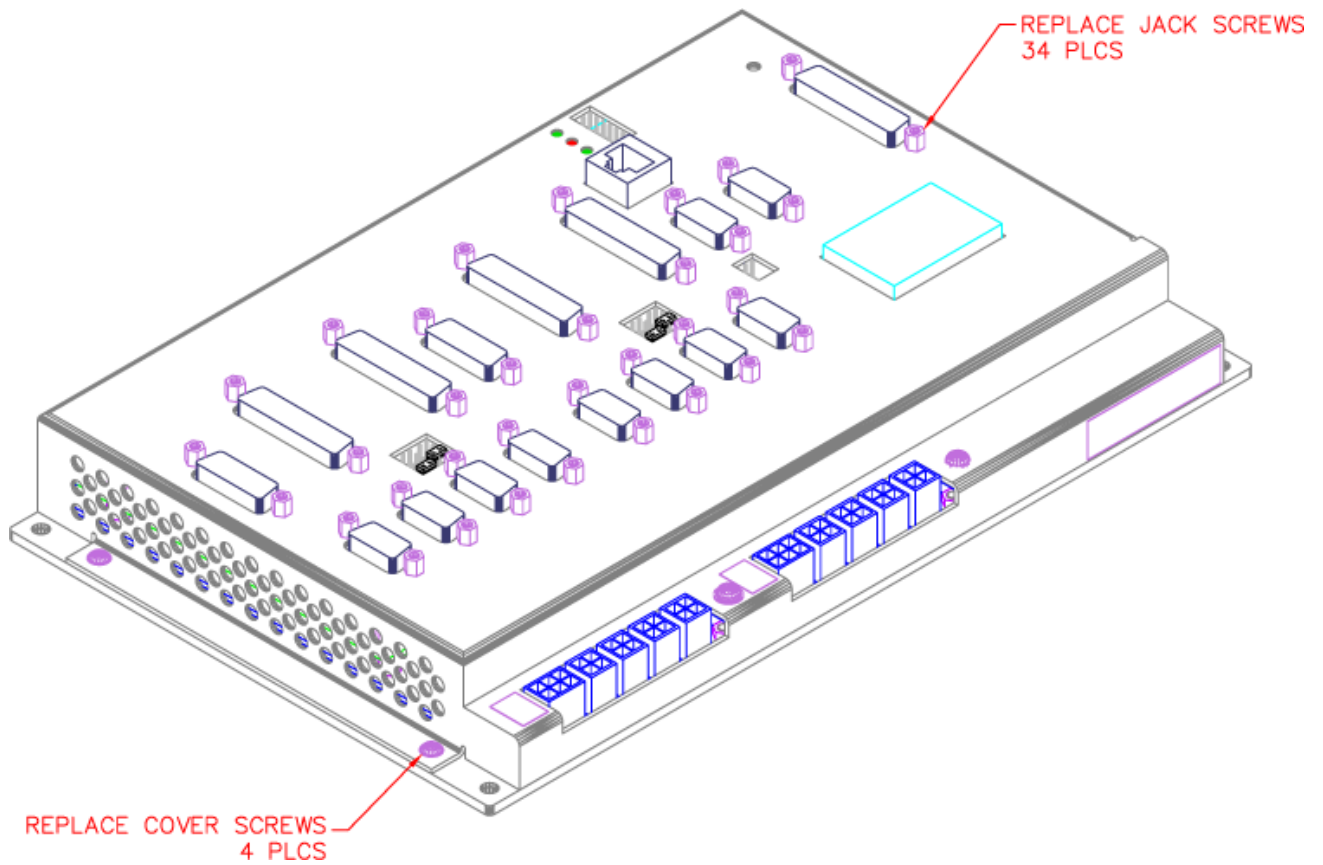

Coordinated Motion - Mathematical Analysis

The terms of coordinated motion are best explained in terms of the vector motion. The vector velocity, V_s , which is also known as the feed rate, is the vector sum of the velocities along the X and Y axes, V_x and V_y .

$$V_s = \sqrt{V_x^2 + V_y^2}$$

The vector distance is the integral of V_s , or the total distance traveled along the path. To illustrate this further, suppose that a string was placed along the path in the X-Y plane. The length of that string represents the distance traveled by the vector motion.

The vector velocity is specified independently of the path to allow continuous motion. The path is specified as a collection of segments. For the purpose of specifying the path, define a special X-Y coordinate system whose origin is the starting point of the sequence. Each linear segment is specified by the X-Y coordinate of the final point expressed in units of resolution, and each circular arc is defined by the arc radius, the starting angle, and the angular width of the arc. The zero angle corresponds to the positive direction of the X-axis and the CCW direction of rotation is positive. Angles are expressed in degrees, and the resolution is 1/256th of a degree. For example, the path shown in Fig. A.1 is specified by the instructions:

VP	0, 10000
CR	10000, 180, -90
VP	20000, 20000

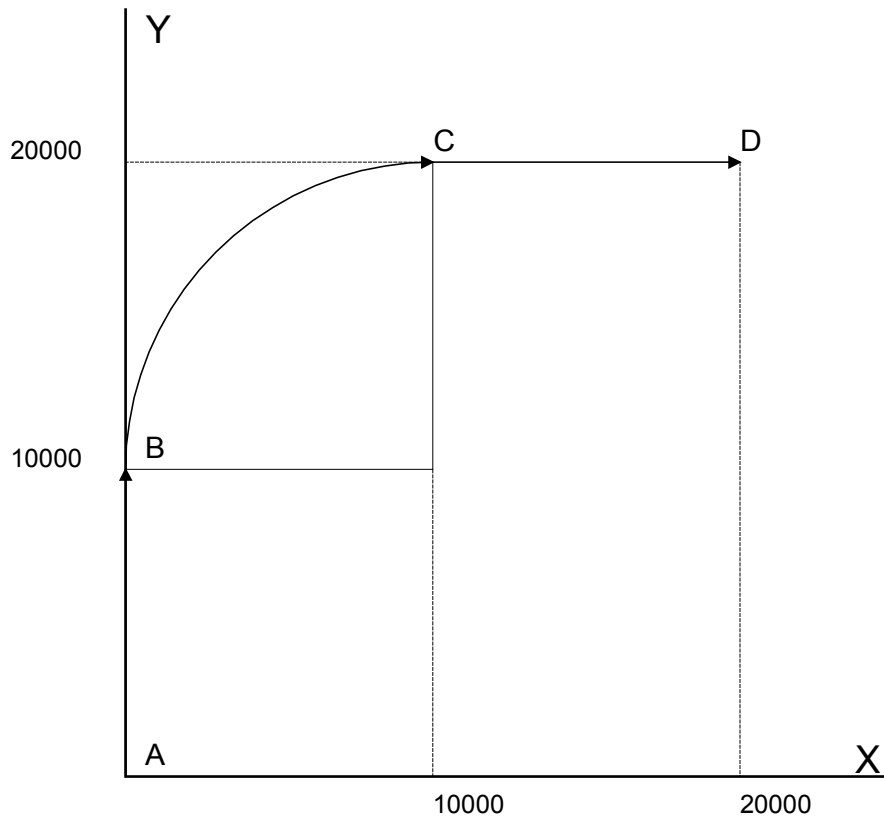

Figure A.1 - X-Y Motion Path

The first line describes the straight line vector segment between points A and B. The next segment is a circular arc, which starts at an angle of 180° and traverses -90°. Finally, the third line describes the linear segment between points C and D. Note that the total length of the motion consists of the segments:

A-B	Linear	10000 units
B-C	Circular	$\frac{R \Delta \theta 2\pi}{360} = 15708$
C-D	Linear	10000
	Total	35708 counts

In general, the length of each linear segment is

$$L_k = \sqrt{Xk^2 + Yk^2}$$

Where Xk and Yk are the changes in X and Y positions along the linear segment. The length of the circular arc is

$$L_k = R_k|\Delta \theta_k|2\pi/360$$

The total travel distance is given by

$$D = \sum_{k=1}^n L_k$$

The velocity profile may be specified independently in terms of the vector velocity and acceleration.

For example, the velocity profile corresponding to the path of Fig. A.2 may be specified in terms of the vector speed and acceleration.

VS 100000
VA 2000000

The resulting vector velocity is shown in Fig. A.2.

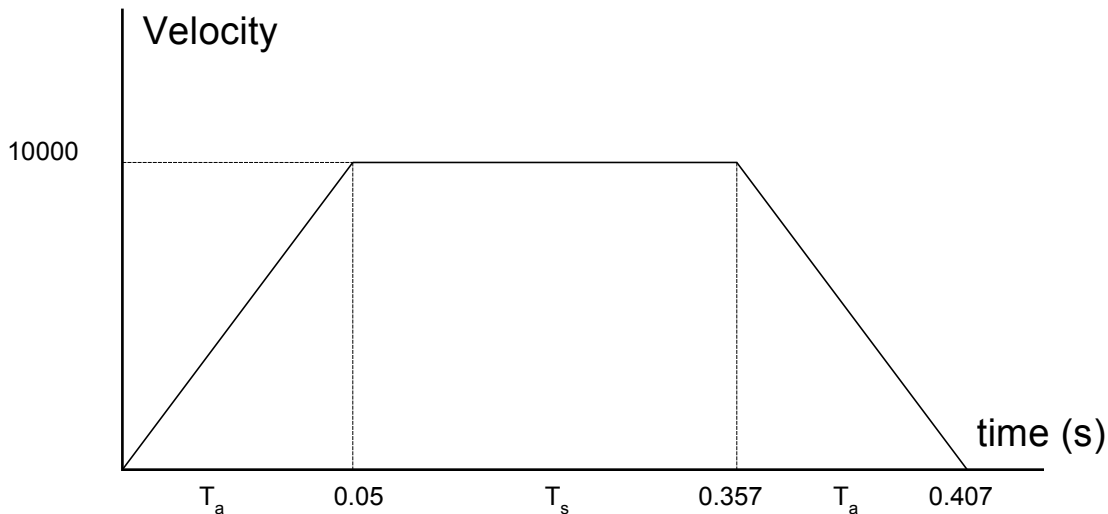

Figure A..2 - Vector Velocity Profile

The acceleration time, Ta, is given by

$$T_a = \frac{VS}{VA} = \frac{100000}{2000000} = 0.05s$$

The slew time, Ts, is given by

$$T_s = \frac{D}{VS} - T_a = \frac{35708}{100000} - 0.05 = 0.307s$$

The total motion time, T_t , is given by:

$$T_t = \frac{D}{VS} + T_a = 0.407s$$

The velocities along the X and Y axes are such that the direction of motion follows the specified path, yet the vector velocity fits the vector speed and acceleration requirements.

For example, the velocities along the X and Y axes for the path shown in Fig. A.1 are given in Fig. A.3.

Fig. A.3a shows the vector velocity. It also indicates the position point along the path starting at A and ending at D. Between the points A and B, the motion is along the Y axis. Therefore,

$$V_y = V_s$$

and

$$V_x = 0$$

Between the points B and C, the velocities vary gradually and finally, between the points C and D, the motion is in the X direction.

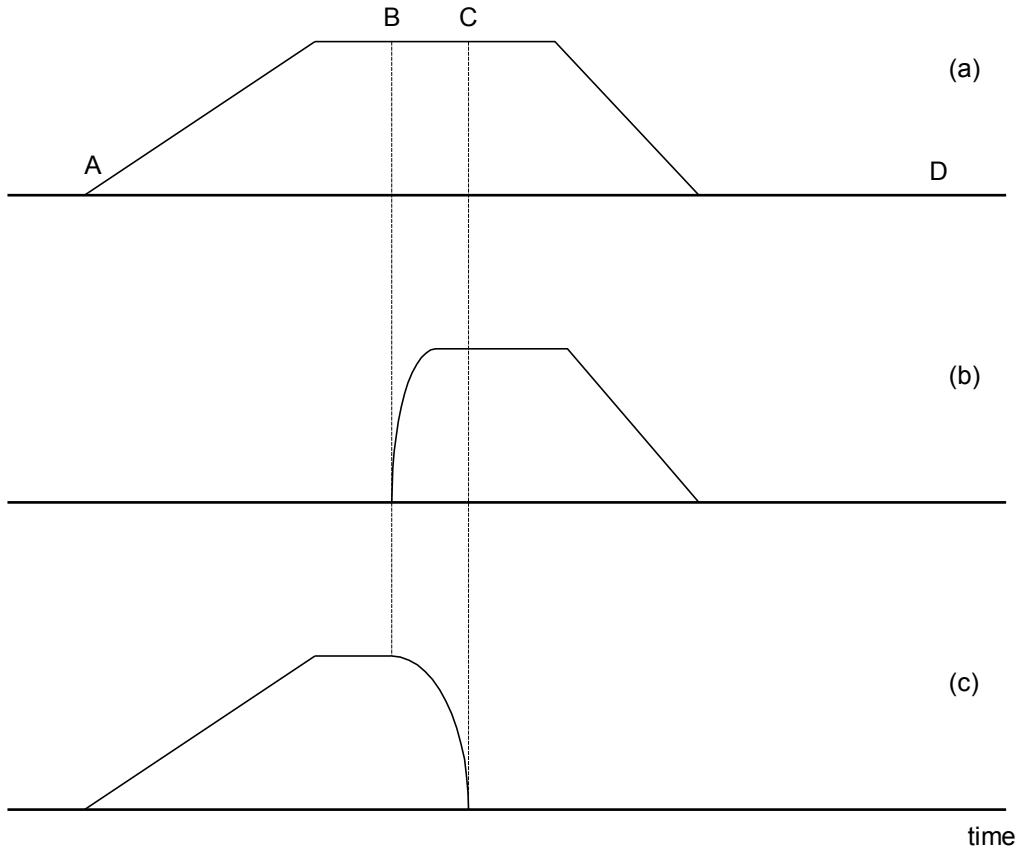

Figure A.3 - Vector and Axes Velocities

Example- Communicating with OPTO-22 SNAP-B3000-ENET

Controller is connected to OPTO-22 via handle F. The OPTO-22's IP address is 131.29.50.30. The Rack has the following configuration:

Digital Inputs	Module 1
Digital Outputs	Module 2
Analog Outputs (+/-10V)	Module 3
Analog Inputs (+/-10V)	Module 4

Instruction	Interpretation
#CONFIG	Label
IHF=131,29,50,30<502>2	Establish connection
WT10	Wait 10 milliseconds
JP #CFGERR,_IHF2=0	Jump to subroutine
JS #CFGDOUT	Configure digital outputs
JS #CFGAOUT	Configure analog outputs
JS #CFGAIN	Configure analog inputs
MBF = 6,6,1025,1	Save configuration to OPTO-22
EN	End
#CFGDOUT	Label
MODULE=2	Set variable
CFGVALUE=\$180	Set variable
NUMOFIO=4	Set variable
JP #CFGJOIN	Jump to subroutine
#CFGAOUT	Label
MODULE=3	Set variable
CFGVALUE=\$A7	Set variable
NUMOFIO=2	Set variable
JP #CFGJOIN	Jump to subroutine
#CFGAIN	Label
MODULE=5	Set variable
CFGVALUE=12	Set variable
NUMOFIO=2	Set variable
JP#CFGJOIN	Jump to subroutine
#CFGJOIN	Label
DM A[8]	Dimension array
I=0	Set variable
#CFGLOOP	Loop subroutine
A[I]=0	Set array element
I=I+1	Increment
A[I]=CFGVALUE	Set array element
I=I+1	Increment

JP #CFGLOOP, I<(2*NUMOFIO)	Conditional statement
MBF=6,16,632+(MODULE*8), NUMOFIO*2, A[]	Configure I/O using Modbus function code 16 where the starting register is 632+(MODULE*8), number of registers is NUMOFIO*2 and A[] contains the data.
EN	end
#CFERR	Label
MG"UNABLE TO ESTABLISH CONNECTION"	Message
EN	End

Using the equation:

$$I/O \text{ number} = (\text{Handlenum} * 1000) + ((\text{Module}-1) * 4) + (\text{Bitnum}-1)$$

MG @IN[6001] display level of input at handle 6, module 1, bit 2

SB 6006 set bit of output at handle 6, module 2, bit 3

or to one

OB 6006,1

AO 608, 3.6 set analog output at handle 6, module 53, bit 1 to 3.6 volts

MG @AN[6017] display voltage value of analog input at handle6, module 5, bit 2

DMC-40x0/DMC-2200 Comparison

BENEFIT	DMC-40x0	DMC-2200
Higher servo bandwidth	Up to 32kHz update rate	Up to 8kHz update rate
Faster Processing power	~10X faster than DMC-20x0	
Increased Program Storage	2000lines x 80 Characters	1000 lines x 80 characters
Increased Array Storage	16000 array elements in 30 arrays	8000 array elements in 30 arrays
Increased Variable Storage	510 Variables	254 labels
Faster servo operation – good for very high resolution sensors	22 MHz encoder speed for servos	12 MHz
Faster stepper operation	6 MHz stepper rate	3 MHz
Improved EMI	Connections broken out through D-Sub connectors and high power amps run away from control lines.	100-pin high density connector and cable.
Contour Buffer	511 elements	1 element
New commands/features	^L^K, PW, %, OV, OT, OA, ALTX, TR1,1, HV, LD, M axis, _EY, ZA, OE2, TM scaling, _NO, LC1000, MT1.5, #POSERR, #LIMSWI, #MCTIME, and #ININT run without a thread	
Removed Commands	VT, WC	

List of Other Publications

"Step by Step Design of Motion Control Systems"

by Dr. Jacob Tal

"Motion Control Applications"

by Dr. Jacob Tal

"Motion Control by Microprocessors"

by Dr. Jacob Tal

Training Seminars

Galil, a leader in motion control with over 500,000 controllers working worldwide, has a proud reputation for anticipating and setting the trends in motion control. Galil understands your need to keep abreast with these trends in order to remain resourceful and competitive. Through a series of seminars and workshops held over the past 20 years, Galil has actively shared their market insights in a no-nonsense way for a world of engineers on the move. In fact, over 10,000 engineers have attended Galil seminars. The tradition continues with three different seminars, each designed for your particular skill set—from beginner to the most advanced.

MOTION CONTROL MADE EASY

WHO SHOULD ATTEND

Those who need a basic introduction or refresher on how to successfully implement servo motion control systems.

TIME: 4 hours (8:30 am-12:30 pm)

ADVANCED MOTION CONTROL

WHO SHOULD ATTEND

Those who consider themselves a "servo specialist" and require an in-depth knowledge of motion control systems to ensure outstanding controller performance. Also, prior completion of "Motion Control Made Easy" or equivalent is required. Analysis and design tools as well as several design examples will be provided.

TIME: 8 hours (8:00 am-5:00 pm)

PRODUCT WORKSHOP

WHO SHOULD ATTEND

Current users of Galil motion controllers. Conducted at Galil's headquarters in Rocklin, CA, students will gain detailed understanding about connecting systems elements, system tuning and motion programming. This is a "hands-on" seminar and students can test their application on actual hardware and review it with Galil specialists.

Attendees must have a current application and recently purchased a Galil controller to attend this course.

TIME: Two days (8:30-4:30pm)

Contacting Us

Galil Motion Control

270 Technology Way

Rocklin, CA 95765

Phone: 916-626-0101

Fax: 916-626-0102

E-Mail Address: support@galilmc.com

URL: <http://galilmc.com/>

FTP: <http://galilmc.com/ftp/>

WARRANTY

All controllers manufactured by Galil Motion Control are warranted against defects in materials and workmanship for a period of 18 months after shipment. Motors, and Power supplies are warranted for 1 year. Extended warranties are available.

In the event of any defects in materials or workmanship, Galil Motion Control will, at its sole option, repair or replace the defective product covered by this warranty without charge. To obtain warranty service, the defective product must be returned within 30 days of the expiration of the applicable warranty period to Galil Motion Control, properly packaged and with transportation and insurance prepaid. We will reship at our expense only to destinations in the United States and for products within warranty.

Call Galil to receive a Return Materials Authorization (RMA) number prior to returning product to Galil.

Any defect in materials or workmanship determined by Galil Motion Control to be attributable to customer alteration, modification, negligence or misuse is not covered by this warranty.

EXCEPT AS SET FORTH ABOVE, GALIL MOTION CONTROL WILL MAKE NO WARRANTIES EITHER EXPRESSED OR IMPLIED, WITH RESPECT TO SUCH PRODUCTS, AND SHALL NOT BE LIABLE OR RESPONSIBLE FOR ANY INCIDENTAL OR CONSEQUENTIAL DAMAGES.

COPYRIGHT (3-97)

The software code contained in this Galil product is protected by copyright and must not be reproduced or disassembled in any form without prior written consent of Galil Motion Control, Inc.

Integrated Components

Overview

When ordered, the following components will reside inside the box of the DMC-40x0 motion controller. The amplifiers and stepper drivers provide power to the motors in the system, and the interconnect modules and communication boards provide the connections for the signals and communications.

A1 – AMP-430x0 (-D3040,-D3020) 2- and 4-axis 500W Servo Drives

The AMP-43040 (four-axis) and AMP-43020 (two-axis) are multi-axis brush/brushless amplifiers that are capable of handling 500 watts of continuous power per axis. The AMP-43040/43020 Brushless drive modules are connected to a DMC-40x0. The standard amplifier accepts DC supply voltages from 18-80 VDC.

A2 – AMP-43140 (-D3140) 4-axis 20W Linear Servo Drives

The AMP-43140 contains four linear drives for operating small brush-type servo motors. The AMP-43140 requires a ± 12 –30 DC Volt input. Output power is 20 W per amplifier or 60 W total. The gain of each transconductance linear amplifier is 0.1 A/V at 1 A maximum current. The typical current loop bandwidth is 4 kHz.

A3 – SDM-44040 (-D4040) 4-axis Stepper Drives

The SDM-44040 is a stepper driver module capable of driving up to four bipolar two-phase stepper motors. The current is selectable with options of 0.5, 0.75, 1.0, and 1.4 Amps/Phase. The step resolution is selectable with options of full, half, 1/4 and 1/16.

A4 – SDM-44140 (-D4140) 4-axis Microstep Drives

The SDM-44140 microstepper module drives four bipolar two-phase stepper motors with 1/64 microstep resolution (the SDM-44140 drives two). The current is selectable with options of 0.5, 1.0, 2.0, & 3.0 Amps per axis.

A5 – CMB-41012 (-C012) Communications Board

The CMB-41012 provides the connections for the Ethernet and serial communication. It also breaks out the Extended I/O into a convenient D-sub connector for interface to external devices.

A6 – ICM-42000 (-I000) Interconnect Module

The ICM-42000 breaks out the internal CPU connector into convenient D-sub connectors for interface to external amplifiers and I/O devices.

A7 – ICM-42100 (-I100) Sinusoidal Encoder Interpolation Module

The ICM-42100 accepts sinusoidal encoder signals instead of digital encoder signals as accepted by the ICM-42000 and the ICM-42200.

A8 – ICM-42200 (-I200) Interconnect Module

The ICM-42200 provides a pin-out that is optimized for easy connection to external drives.

A1 – AMP-430x0 (-D3040,-D3020)

Description

The AMP-43040 resides inside the DMC-40x0 enclosure and contains four transconductance, PWM amplifiers for driving brushless or brush-type servo motors. Each amplifier drives motors operating at up to 7 Amps continuous, 10 Amps peak, 20–80 VDC. The gain settings of the amplifier are user-programmable at 0.4 Amp/Volt, 0.7 Amp/Volt and 1 Amp/Volt. The switching frequency is 60 kHz. The drive for each axis is software configurable to operate in either a chopper or inverter mode. The chopper mode is intended for operating low inductance motors. The amplifier offers protection for over-voltage, under-voltage, over-current, short-circuit and over-temperature. Two AMP-43040s are required for 5- thru 8-axis controllers. A shunt regulator option is available. A two-axis version, the AMP-43020 is also available. If higher voltages are required, please contact Galil.



Figure A1-1 – DMC-4040-C012-I000-D3040 (DMC-4040 with AMP-43040)

Electrical Specifications

The amplifier is a brush/brushless trans-conductance PWM amplifier. The amplifier operates in torque mode, and will output a motor current proportional to the command signal input.

Supply Voltage:	18-80 VDC
Continuous Current:	7 Amps
Peak Current	10 Amps
Nominal Amplifier Gain	0.7 Amps/Volt
Switching Frequency	60 kHz (up to 140 kHz available-contact Galil)
Minimum Load Inductance:	0.5 mH (Inverter mode) 0.2 mH (Chopper Mode)
Brushless Motor Commutation angle	120° (60° option available)

Mating Connectors

	On Board Connector	Terminal Pins
POWER	6-pin MATE-N-LOK MOLEX# 39-31-0060	MOLEX#44476-3112
A,B,C,D: 4-pin Motor Power Connectors	4-pin MATE-N-LOK MOLEX# 39-31-0040	MOLEX#44476-3112

For mating connectors see <http://www.molex.com/>

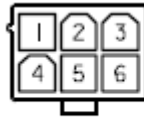

Power Connector

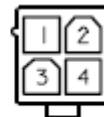

Motor Connector

Power Connector	
Pin Number	Connection
1,2,3	DC Power Supply Ground
4,5,6	+VS (DC Power)
Motor Connector	
1	Phase C (N/C for Bushed Motors)
2	Phase B
3	No Connect
4	Phase A

Operation

Brushless Motor Setup

Note: If you purchased a Galil motor with the amplifier, it is ready for use. No additional setup is necessary.

To begin the setup of the brushless motor and amplifier, it is first necessary to have communications with the motion controller. Refer to the user manual supplied with your controller for questions regarding controller communications. It is also necessary to have the motor hardware connected and the amplifier powered to begin the setup phase. After the encoders and motor leads are connected, the controller and amplifier need to be configured correctly in software. Take all appropriate safety precautions. For example, set a small error limit ($ER^*=1000$), a low torque limit ($TL^*=3$), and set off on Error to 1 for all axes ($OE^*=1$). Review the command reference and controller user manual for further details.

There are 3 settings for the amplifier gain: 0.4 A/V, 0.7 A/V, and 1.0 A/V corresponding to AG (amplifier gain) 0, 1 and 2. If the gain is set to 0.7 A/V, a torque limit of 3 ($TLn=3$) will allow the amplifier to output no more than 2.1 amps of current on the specified axis. The controller has been programmed to test whether the Hall commutation order is correct. To test the commutation for the X axis, issue the BS command ($BSX=n,m$). The controller will attempt to move the motor through one revolution. If the motor is unable to move, the controller will return “unknown Hall transition”, check wiring, and execute BS again’. It may be necessary to issue more voltage to create motion. The default for the BS command is $BSn=0.25,1000$ which will send 0.25 volts to the amplifier for 1 second. $BSX=0.5,300$ will issue 0.5 volts from the controller for 300 milliseconds. If the controller is able to move the motor and the Hall transitions are not correct, the controller will alert the operator and recommend which motor phases to change. For example, the controller might return “Wire A to Terminal B, Wire B to Terminal A.” If the controller finds that the commutation order is correct, but the motor would run away due to positive feedback, the controller will prompt the user to “Wire Phase B to C and C to B. Exchange Hall Sensors A and B...”. After making any necessary changes to the motor phase wiring, confirm correct operation by reissuing the BS command. Once the axis is wired correctly, the controller is ready to perform closed-loop motion.

Brushless Amplifier Software Setup

Select the amplifier gain that is appropriate for the motor. The amplifier gain command (AG) can be set to 0, 1, or 2 corresponding to 0.4, 0.7, and 1.0 A/V. In addition to the gain, peak and continuous torque limits can be set through TK and TL respectively. The TK and TL values are entered in volts on an axis by axis basis. The peak limit will set the maximum voltage that will be output from the controller to the amplifier. The continuous current will set what the maximum average current is over a one second interval. The following figure captured with WSDK is indicative of the operation of the continuous and peak operation. In this figure, the continuous limit was configured for 2 volts, and the peak limit was configured for 10 volts.

Chopper Mode

The AMP-43040 can be put into what is called a “Chopper” mode. The chopper mode is in contrast to the normal inverter mode in which the amplifier sends PWM power to the motor of +/-VS. In chopper mode, the amplifier sends a 0 to +VS PWM to the motor when moving in the forward direction, and a 0 to -VS PWM to the motor when moving in the negative direction.

This mode is useful when using low inductance motors because it reduces the losses due to switching voltages across the motor windings. It is recommended to use chopper mode when using motors with 200-500 μ H inductance.

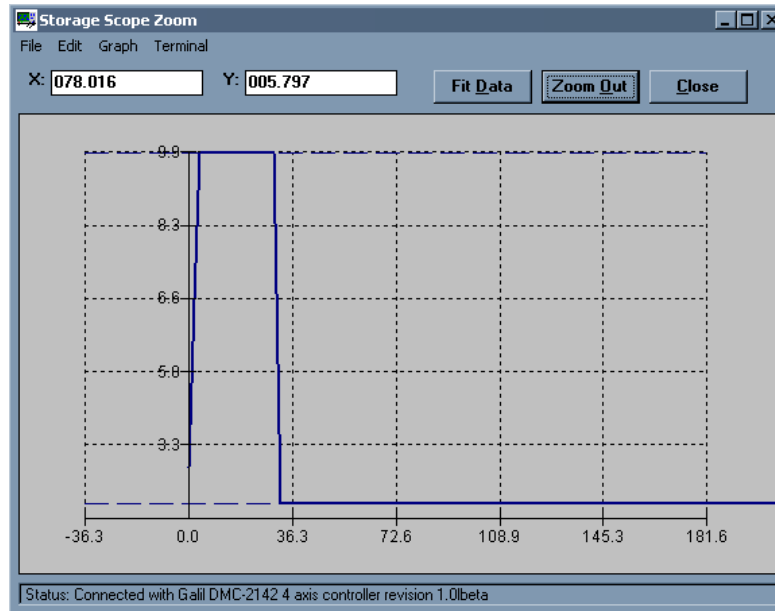

Figure A1-2 Peak Current Operation

With the AMP-43040 and 43020, the user is also given the ability to choose between normal and high current bandwidth (AU). In addition, the user can calculate what the bandwidth of the current loop is for their specific combination (AW). To select normal current loop gain for the X axis and high current loop gain for the Y axis, issue AU 0,1. The command AW is used to calculate the bandwidth of the amplifier using the basic amplifier parameters. To calculate the bandwidth for the X axis, issue AWX=v,l,n where v represents the DC voltage input to the card, l represents the inductance of the motor in millihenries, and n represents 0 or 1 for the AU setting.

Note: For most applications, unless the motor has more than 5 mH of inductance with a 24V supply, or 10 mH of inductance with a 48 volts supply, the normal current loop bandwidth option should be chosen. AW will return the current loop bandwidth in Hertz.

Brush Amplifier Operation

The AMP-43040 and AMP-43020 also allow for brush operation. To configure an axis for brush-type operation, connect the 2 motor leads to Phase A and Phase B connections for the axis. Connect the encoders, homes, and limits as required. Set the controller into brush-axis operation by issuing BR n,n,n,n. By setting n=1, the controller will operate in brushed mode on that axis. For example, BR0,1,0,0 sets the Y-axis as brush-type, all others as brushless. If an axis is set to brush-type, the amplifier has no need for the Hall inputs. These inputs can subsequently be used as general-use inputs, queried with the QH command. The gain settings for the amplifier are identical for the brush and brushless operation. The gain settings can be set to 0.4, 0.7, or 1.0 A/V, represented by gain values of 0, 1, and 2 (e.g., AG 0,0,2,1). The current loop gain AU can also be set to either 0 for normal, or 1 for high current loop gain.

Using External Amplifiers

Use connectors on top of controller to access necessary signals to run external amplifiers. In order to use the full torque limit, make sure the AG setting for the axes using external amplifiers are set to 0 or 1. For more information on connecting external amplifiers, see Connecting to External Amplifiers in Chapter 2.

Error Monitoring and Protection

The amplifier is protected against over-voltage, under-voltage, over-temperature, and over-current for brush and brushless operation. The controller will also monitor for illegal Hall states (000 or 111 with 120° phasing). The controller will monitor the error conditions and respond as programmed in the application. The errors are monitored

via the TA command. TA n may be used to monitor the errors with n = 0, 1, 2, or 3. The command will return an eight bit number representing specific conditions. TA0 will return errors with regard to under voltage, over voltage, over current, and over temperature. TA1 will return hall errors on the appropriate axes, TA2 will monitor if the amplifier current exceeds the continuous setting, and TA3 will return if the ELO input has been triggered.

The user also has the option to include the special label #AMPERR in their program to handle soft or hard errors. As long as a program is executing in thread zero, and the #AMPERR label is included, when an error is detected, the program will jump to the label and execute the user defined routine. Note that the TA command is a monitoring function only, and does not generate an error condition. The over voltage condition will not permanently shut down the amplifier or trigger the #AMPERR routine. The amplifier will be momentarily disabled; when the condition goes away, the amplifier will continue normal operation assuming it did not cause the position error to exceed the error limit.

Hall Error Protection

During normal operation, the controller should not have any Hall errors. Hall errors can be caused by a faulty Hall-effect sensor or a noisy environment. If at any time the Halls are in an invalid state, the appropriate bit of TA1 will be set. The state of the Hall inputs can also be monitored through the QH command. Hall errors will cause the amplifier to be disabled if OE 1 is set, and will cause the controller to enter the #AMPERR subroutine if it is included in a running program.

Under-Voltage Protection

If the supply to the amplifier drops below 12 VDC, the amplifier will be disabled. The amplifier will return to normal operation once the supply is raised above the 12V threshold; bit 3 of the error status (TA0) will tell the user whether the supply is in the acceptable range.

Note: If there is an #AMPERR routine and the controller is powered before the amplifier, then the #AMPERR routine will automatically be triggered.

Over-Voltage Protection

If the voltage supply to the amplifier rises above 92 VDC, then the amplifier will automatically disable. The amplifier will re-enable when the supply drops below 90 V. This error is monitored with bit 1 of the TA0 command.

Over-Current Protection

The amplifier also has circuitry to protect against over-current. If the total current from a set of 2 axes (ie A and B or C and D) exceeds 20 A, the amplifier will be disabled. The amplifier will not be re-enabled until there is no longer an over-current draw and then either SH command has been sent or the controller is reset. Since the AMP-43040 is a trans-conductance amplifier, the amplifier will never go into this mode during normal operation. The amplifier will be shut down regardless of the setting of OE, or the presence of the #AMPERR routine. Bit 0 of TA0 will be set.

Note: If this fault occurs, it is indicative of a problem at the system level. An over-current fault is usually due to a short across the motor leads or a short from a motor lead to ground.

Over-Temperature Protection

The controller is also equipped with over-temperature protection.

Rev A and Rev B amplifiers:

If the average heat sink temperature rises above 100°C, then the amplifier will be disabled. Bit 2 of TA0 will be set when the over-temperature occurs on the A-D axis amplifier, and Bit 6 of TA0 will be set when the over-temperature occurs on the E-H axis amplifier. The over-temperature condition will trigger the #AMPERR routine if included in the program on the controller.

The amplifier will re-enable when the temperature drops below 100 °C.

Rev C and newer amplifiers:

If the average heat sink temperature rises above 80°C, then the amplifier will be disabled. Bit 2 of TA0 will be set when the over-temperature occurs on the A-D axis amplifier, and Bit 6 of TA0 will be set when the over-temperature occurs on the E-H axis amplifier. The over-temperature condition will trigger the #AMPERR routine if included in the program on the controller.

The amplifier will not be re-enabled until the temperature drops below 80°C and then either an SH command is sent to the controller, or the controller is reset (RS command or power cycle).

Rev C Amplifiers began shipping in December 2008.

ELO Input

If the ELO input on the controller is triggered, then the amplifier will be shut down at a hardware level, the motors will be essentially in a Motor Off (MO) state. TA3 will return a 3 and the #AMPERR routine will run when the ELO input is triggered. To recover from an ELO, an MO then SH must be issued, or the controller must be reset.

It is recommended that OE1 be used for all axes when the ELO is used in an application.

A2 – AMP-43140 (-D3140)

Description

The AMP-43140 resides inside the DMC-40x0 enclosure and contains four linear drives for operating small, brush-type servo motors. The AMP-43140 requires a ± 12 -30 VDC input. Output power is 20 W per amplifier or 60 W total. The gain of each transconductance linear amplifier is 0.1 A/V at 1 A maximum current. The typical current loop bandwidth is 4 kHz.

The AMP-43140 can be ordered to have a 100mA maximum current output where the gain of the amplifier is 10mA/V. Order as '-D3140(100mA)'.

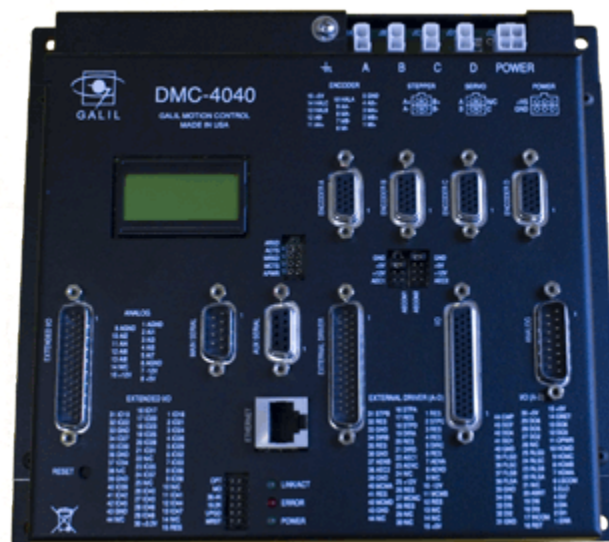

Figure A2-1 – DMC-4040-C012-I000-D3140 (DMC-4040 with AMP-43140)

Electrical Specifications

The amplifier is a brush type trans-conductance linear amplifier. The amplifier operates in torque mode, and will output a motor current proportional to the command signal input.

DC Supply Voltage:	+/-12-30 VDC (bipolar)
Max Current (per axis)	1.0 Amps (100mA option)
Amplifier gain:	0.1 A/V (10mA/V option)
Power output (per channel):	20 W
Total max. power output:	60 W

Mating Connectors

	On Board Connector	Terminal Pins
POWER	4-pin MATE-N-LOK MOLEX# 39-01-2045	MOLEX#44476-3112
A,B,C,D: 4-pin Motor Power Connectors	2-pin MATE-N-LOK MOLEX# 39-01-2025	MOLEX#44476-3112

For mating connectors see <http://www.molex.com/>

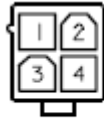

Power Connector



Motor Connector

Power Connector	
Pin Number	Connection
1,2	Power Supply Ground
3	-VS (-DC Power)
4	+VS (DC Power)
Motor Connector	
1	Motor Lead A-
2	Motor Lead A+

Operation

Using External Amplifiers

Use connectors on top of controller to access necessary signals to run external amplifiers. For more information on connecting external amplifiers, see Connecting to External Amplifiers in Chapter 2.

ELO Input

If the ELO input on the controller is triggered, then the amplifier will be shut down at a hardware level, the motors will be essentially in a Motor Off (MO) state. TA3 will return a 3 and the #AMPERR routine will run when the ELO input is triggered. To recover from an ELO, an MO then SH must be issued, or the controller must be reset.

It is recommended that OE1 be used for all axes when the ELO is used in an application.

-SSR Option

The AMP-43140 linear amplifier require a bipolar power supply. It is possible that the plus and minus (V+ and V-) rise to nominal voltage at different rates during power up and any difference between voltage levels will be seen as an offset in the motor. This offset may cause a slight jump during power up prior to the controller establishing closed-loop control. When ordered with the -SSR option a solid state relay is added to the amplifier. This relay disconnects the amplifier power from the motor power leads when the controller is placed in the motor-off state. If the MO jumper is installed, or the MO command is burned into memory, the addition of the -SSR option will eliminate any jump.

A3 – SDM-44040 (-D4040)

Description

The SDM-44040 resides inside the DMC-40x0 enclosure and contains four drives for operating two-phase bipolar step motors. The SDM-44040 requires a single 12-30 VDC input. The unit is user-configurable for 1.4 A, 1.0 A, 0.75 A, or 0.5 A per phase and for full-step, half-step, 1/4 step or 1/16 step.



Figure A3-1 – DMC-4040-C012-I000-D4040 (DMC-4040 with SDM-44040)

Electrical Specifications

DC Supply Voltage:	12-30 VDC
Max Current (per axis)	1.4 Amps/Phase Amps (Selectable with AG command)
Maximum Step Frequency:	6 MHz
Motor Type:	Bipolar 2 Phase

Mating Connectors

	On Board Connector	Terminal Pins
POWER	6-pin MATE-N-LOK MOLEX# 39-31-0060	MOLEX#44476-3112
A,B,C,D: 4-pin Motor Power Connectors	4-pin MATE-N-LOK MOLEX# 39-31-0040	MOLEX#44476-3112

For mating connectors see <http://www.molex.com/>

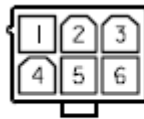

Power Connector



Motor Connector

Power Connector	
Pin Number	Connection
1,2,3	DC Power Supply Ground
4,5,6	+VS (DC Power)
Motor Connector	
1	B-
2	A-
3	B+
4	A+

Operation

The AG command sets the current on each axis, the LC command configures each axis's behavior when holding position and the YA command sets the step driver resolution. These commands are detailed below, see also the command reference for more information:

Current Level Setup (AG Command)

AG configures how much current the SDM-206x0 delivers to each motor. Four options are available: 0.5A, 0.75A, 1.0A, and 1.4 Amps

Drive Current Selection per Axis: AG n,n,n,n,n,n,n

n = 0	0.5 A
n = 1	0.75 A (default)
n = 2	1.0 A
n = 3	1.4 A

Low Current Setting (LC Command)

LC configures each motor's behavior when holding position (when RP is constant) and multiple configurations:

LC command set to 0 "Full Current Mode" - causes motor to use 100% of peak current (AG) while at a "resting" state (profiler is not commanding motion). This is the default setting.

LC command set to 1 "Low Current Mode" - causes motor to use 25% of peak current while at a "resting" state. This is the recommended configuration to minimize heat generation and power consumption.

LC command set to an integer between 2 and 32767 specifying the number of samples to wait between the end of the move and when the amp enable line toggles

Percentage of full (AG) current used while holding position with LC n,n,n,n,n,n,n

n = 0	100%
n = 1	25%

The LC command must be entered after the motor type has been selected for stepper motor operation (i.e. MT-2,-2,-2,-2). LC is axis-specific, thus LC1 will cause only the X-axis to operate in "Low Current" mode.

Step Drive Resolution Setting (YA command)

When using the SDM-44040, the step drive resolution can be set with the YA command

Step Drive Resolution per Axis: YA n,n,n,n,n,n,n

n = 1	Full
n = 2	Half
n = 4	1/4
n = 16	1/16

ELO Input

If the ELO input on the controller is triggered, then the amplifier will be shut down at a hardware level, the motors will be essentially in a Motor Off (MO) state. TA3 will return a 3 and the #AMPERR routine will run when the ELO input is triggered. To recover from an ELO, an MO then SH must be issued, or the controller must be reset.

It is recommended that OE1 be used for all axes when the ELO is used in an application.

A4 – SDM-44140 (-D4140)

Description

The SDM-44140 resides inside the DMC-40x0 enclosure and contains four microstepping drives for operating two-phase bipolar stepper motors. The drives produce 64 microsteps per full step or 256 steps per full cycle which results in 12,800 steps/rev for a standard 200-step motor. The maximum step rate generated by the controller is 6,000,000 microsteps/second. The SDM-44140 drives motors operating at up to 3 Amps at 12 to 60 VDC (available voltage at motor is 10% less). There are four softwareselectable current settings: 0.5 A, 1 A, 2 A and 3 A. Plus, a selectable lowcurrent mode reduces the current by 75% when the motor is not in motion. No external heatsink is required.



Figure A1-1 – DMC-4040-C012-I000-D4140 (DMC-4040 with SDM-44140)

Electrical Specifications

DC Supply Voltage:	12-60 VDC
Max Current (per axis)	3.0 Amps (Selectable with AG command)
Max Step Frequency:	6 MHz
Motor Type:	Bipolar 2 Phase
Switching Frequency:	60 kHz
Minimum Load Inductance:	0.5 mH

Mating Connectors

	On Board Connector	Terminal Pins
POWER	6-pin MATE-N-LOK MOLEX# 39-01-2065	MOLEX#44476-3112
A,B,C,D: 4-pin Motor Power Connectors	4-pin MATE-N-LOK MOLEX# 39-01-2045	MOLEX#44476-3112

For mating connectors see <http://www.molex.com/>

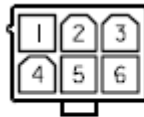

Power Connector



Motor Connector

Power Connector	
Pin Number	Connection
1,2,3	DC Power Supply Ground
4,5,6	+VS (DC Power)
Motor Connector	
1	B-
2	A-
3	B+
4	A+

Operation

The AG command sets the current on each axis and the LC command configures each axis's behavior when holding position. These commands are detailed below:

Current Level Setup (AG Command)

AG configures how much current the SDM-44140 delivers to each motor. Four options are available: 0.5A, 1.0A, 2.0A, and 3.0Amps (**Note:** when using the 3.0A setting, mounting the unit to a metal or heat dissipating surface is recommended).

Drive Current Selection per Axis: AG n,n,n,n,n,n,n,n

n = 0	0.5 A
n = 1	1 A (default)
n = 2	2 A
n = 3	3.0 A

Low Current Setting (LC Command)

LC configures each motor's behavior when holding position (when RP is constant) and multiple configurations:

LC command set to 0 "Full Current Mode" - causes motor to use 100% of peak current (AG) while at a "resting" state (profiler is not commanding motion). This is the default setting.

LC command set to 1 "Low Current Mode" - causes motor to use 25% of peak current while at a "resting" state. This is the recommended configuration to minimize heat generation and power consumption.

LC command set to an integer between 2 and 32767 specifying the number of samples to wait between the end of the move and when the amp enable line toggles

Percentage of full (AG) current used while holding position with LC n,n,n,n,n,n,n

n = 0	100%
n = 1	25%

The LC command must be entered after the motor type has been selected for stepper motor operation (i.e. MT-2,-2,-2,-2). LC is axis-specific, thus LC1 will cause only the X-axis to operate in "Low Current" mode.

ELO Input

If the ELO input on the controller is triggered, then the amplifier will be shut down at a hardware level, the motors will be essentially in a Motor Off (MO) state. TA3 will return a 3 and the #AMPERR routine will run when the ELO input is triggered. To recover from an ELO, an MO then SH must be issued, or the controller must be reset.

It is recommended that OE1 be used for all axes when the ELO is used in an application.

A5 – CMB-41012 (-C012)

Description

The CMB-41012 provides the connections for the Ethernet and Serial communication as well as the D-Sub connector for the Extended I/O. The CMB-41012 also contains the 8x2 character LCD. See Chapter 3 for Electrical Specifications of Extended I/O.

Connectors for CMB-41012 Interconnect Board

CMB-41012 Extended I/O 44 pin HD D-Sub Connector (Male)

Pin#	Label	Description	Pin#	Label	Description	Pin#	Label	Description
1	IO18	Configurable I/O bit 18	16	IO17	Configurable I/O bit 17	31	IO19	Configurable I/O bit 19
2	IO21	Configurable I/O bit 21	17	IO20	Configurable I/O bit 20	32	IO22	Configurable I/O bit 22
3	IO24	Configurable I/O bit 24	18	IO23	Configurable I/O bit 23	33	GND	Digital Ground
4	IO26	Configurable I/O bit 26	19	IO25	Configurable I/O bit 25	34	IO27	Configurable I/O bit 27
5	IO29	Configurable I/O bit 29	20	IO28	Configurable I/O bit 28	35	IO30	Configurable I/O bit 30
6	IO32	Configurable I/O bit 32	21	IO31	Configurable I/O bit 31	36	GND	Digital Ground
7	IO33	Configurable I/O bit 33	22	N/C	No Connect	37	IO34	Configurable I/O bit 34
8	IO36	Configurable I/O bit 36	23	IO35	Configurable I/O bit 35	38	N/C	No Connect
9	IO38	Configurable I/O bit 38	24	IO37	Configurable I/O bit 37	39	GND	Digital Ground
10	N/C	No Connect	25	N/C	No Connect	40	IO39	Configurable I/O bit 39
11	IO41	Configurable I/O bit 41	26	IO40	Configurable I/O bit 40	41	IO42	Configurable I/O bit 42
12	IO44	Configurable I/O bit 44	27	IO43	Configurable I/O bit 43	42	IO45	Configurable I/O bit 45
13	IO47	Configurable I/O bit 47	28	IO46	Configurable I/O bit 46	43	GND	Digital Ground
14	N/C	No Connect	29	IO48	Configurable I/O bit 48	44	N/C	No Connect
15	RES	Reserved ¹	30	+3.3V	+3.3V ²			

Notes:

- 1 5V when (5V) option is ordered on CMB. Ex *DMC-4040-C012(5V)-I200*
- 2 Reserved when (5V) option is ordered on CMB

RS-232-Main Port (Male)

Standard connector and cable, 9Pin

Pin	Signal
1	NC
2	TXD
3	RXD
4	NC
5	GND
6	NC
7	CTS
8	RTS
9	NC

RS-232-Auxiliary Port (Female)

Standard connector and cable, 9Pin

Pin #	Signal
1	NC
2	TXD
3	RXD
4	NC
5	GND
6	NC
7	RTS
8	CTS
9	NC (5V with APWR Jumper)

RS-422-Main Port (Non-Standard Option)

Standard connector and cable when DMC-40x0 is ordered with RS-422 Option.

Pin #	Signal
1	RTS-
2	TXD-
3	RXD-
4	CTS-
5	GND
6	RTS+
7	TXD+
8	RXD+
9	CTS+

RS-422-Auxiliary Port (Non-Standard Option)

Standard connector and cable when DMC-40x0 is ordered with RS-422 Option.

Pin #	Signal
1	CTS-
2	RXD-
3	TXD-
4	RTS-
5	GND
6	CTS+
7	RXD+
8	TXD+
9	RTS+

Ethernet

100 BASE-T/10 BASE-T - Kycon GS-NS-88-3.5

Pin #	Signal
1	TXP
2	TXN
3	RXP
4	NC
5	NC
6	RXN
7	NC
8	NC

10 BASE-2- AMP 227161-7

10 BASE-F- HP HFBR-1414 (TX, Transmitter)

HP HFBR-2416 (RX, Receiver)

Jumper Description for CMB-41012

Jumper	Label	Function (If jumpered)
Communications	OPT	Reserved
	MO	When controller is powered on or reset, Amplifier Enable lines will be in a Motor Off state. A SH will be required to re-enable the motors.
	38.4K	Baud Rate setting – see table below
	19.2K	Baud Rate setting – see table below
	UPGD	Used to upgrade controller firmware when resident firmware is corrupt.
	MRST	Master Reset enable. Returns controller to factory default settings and erases EEPROM. Requires power-on or RESET to be activated.

Baud Rate Jumper Settings

19.2	38.4	BAUD RATE
ON	ON	9600
ON	OFF	19200
OFF	ON	38400
OFF	OFF	115200

A6 – ICM-42000 (-I000)

Description

The ICM-42000 resides inside the DMC-40x0 enclosure and breaks out the internal CPU board connector into convenient D-sub connectors for interface to external amplifiers and I/O devices. The ICM-42000 provides a 15-pin HD D-sub connector for the encoders on each axis, a 15-pin D-sub for analog inputs, a 44-pin HD D-sub for I/O, and a 44-pin D-sub for the motor command signals. Eight 500 mA highside drive outputs are available (total current not to exceed 3 A). The ICM-42000 is user-configurable for a broad range of amplifier enable options including: High amp enable, Low amp enable, 5 V logic, 12 V logic, external voltage supplies up to 24 V and sinking or sourcing. Two ICMs are required for 5- thru 8-axis controllers.

For more information regarding the Amplifier Enable Operation, see Chapter 3 and Configuring the Amplifier Enable Circuit in the Appendix.

For electrical specifications on the I/O, see Chapter 3.

Connectors for ICM-42000 Interconnect Board

ICM-42000 I/O (A-D) 44 pin HD D-Sub Connector (Female)

Pin#	Label	Description	Pin#	Label	Description	Pin#	Label	Description
1	ERR	Error Output	16	RST	Reset Input	31	GND	Digital Ground
2	DI1	Digital Input 1 / A latch	17	INCOM	Input Common	32	DI2	Digital Input 2 / B latch
3	DI4	Digital Input 4 / D latch	18	DI3	Digital Input 3 / C latch	33	DI5	Digital Input 5
4	DI7	Digital Input 7	19	DI6	Digital Input 6	34	DI8	Digital Input 8
5	ELO	Electronic Lock Out	20	ABRT	Abort Input	35	GND	Digital Ground
6	LSCOM	Limit Switch Common	21	N/C	No Connect	36	FLSA	Forward Limit Switch A
7	HOMA	Home Switch A	22	RLSA	Reverse Limit Switch A	37	FLSB	Forward Limit Switch B
8	HOMB	Home Switch B	23	RLSB	Reverse Limit Switch B	38	FLSC	Forward Limit Switch C
9	HOMC	Home Switch C	24	RLSC	Reverse Limit Switch C	39	FLSD	Forward Limit Switch D
10	HOMD	Home Switch D	25	RLSD	Reverse Limit Switch D	40	GND	Digital Ground
11	OPWR	Output Power	26	N/C	No Connect	41	DO1	Digital Output 1
12	DO3	Digital Output 3	27	DO2	Digital Output 2	42	DO4	Digital Output 4
13	DO6	Digital Output 6	28	DO5	Digital Output 5	43	DO7	Digital Output 7
14	ORET	Output Return	29	DO8	Digital Output 8	44	CMP	Output Compare
15	+5V	+5V	30	+5V	+5V			

ICM-42000 I/O (E-H) 44 pin HD D-Sub Connector (Female)

4080

For DMC-4050 thru DMC-4080 controllers only.

Pin#	Label	Description	Pin#	Label	Description	Pin#	Label	Description
1	ERR	Error Output	16	RST	Reset Input	31	GND	Digital Ground
2	DI9	Digital Input 9 / E latch	17	INCOM	Input Common	32	DI10	Digital Input 10 / F latch
3	DI12	Digital Input 12/H latch	18	DI11	Digital Input 11 / G latch	33	DI13	Digital Input 13
4	DI15	Digital Input 15	19	DI14	Digital Input 14	34	DI16	Digital Input 16
5	ELO	Electronic Lock Out	20	ABRT	Abort Input	35	GND	Digital Ground
6	LSCOM	Limit Switch Common	21	N/C	No Connect	36	FLSE	Forward Limit Switch E
7	HOME	Home Switch E	22	RLSE	Reverse Limit Switch E	37	FLSF	Forward Limit Switch F
8	HOMF	Home Switch F	23	RLSF	Reverse Limit Switch F	38	FLSG	Forward Limit Switch G
9	HOMG	Home Switch G	24	RLSG	Reverse Limit Switch G	39	FLSH	Forward Limit Switch H
10	HOMH	Home Switch H	25	RLSH	Reverse Limit Switch H	40	GND	Digital Ground
11	OPWR	Output Power	26	N/C	No Connect	41	DO9	Digital Output 9
12	DO11	Digital Output 11	27	DO10	Digital Output 10	42	DO12	Digital Output 12
13	DO14	Digital Output 14	28	DO13	Digital Output 13	43	DO15	Digital Output 15
14	ORET	Output Return	29	DO16	Digital Output 16	44	CMP	Output Compare
15	+5V	+5V	30	+5V	+5V			

ICM-42000 External Driver (A-D) 44 pin HD D-Sub Connector (Male)

Pin#	Label	Description	Pin#	Label	Description	Pin#	Label	Description
1	RES	Reserved / Step A _N ²	16	STPA	PWM / Step A	31	STPB	PWM / Step B
2	STPC	PWM / Step C	17	RES	Reserved / Step B _N ²	32	RES	Reserved / Step C _N ²
3	RES	Reserved / Step D _N ²	18	STPD	PWM / Step D	33	GND	Digital Ground
4	RES	Reserved / Dir A _N ²	19	DIRA	Sign / Direction A	34	DIRB	Sign / Direction B
5	DIRC	Sign / Direction C	20	RES	Reserved / Dir B _N ²	35	RES	Reserved / Dir C _N ²
6	RES	Reserved / Dir D _N ²	21	DIRD	Sign / Direction D	36	GND	Digital Ground
7	AENA	Amplifier Enable A	22	AEC1	Amp Enable Common 1	37	AENB	Amplifier Enable B
8	AEND	Amplifier Enable D	23	AENC	Amplifier Enable C	38	AEC2	Amp Enable Common 2
9	N/C	No Connect	24	N/C	No Connect	39	GND	Digital Ground
10	-12V	-12V	25	+12V	+12V	40	MCMA	Motor Command A
11	MCMB	Motor Command B	26	RES	Reserved / MCMDA _N ¹	41	RES	Reserved / MCMDB _N ¹
12	RES	Reserved / MCMDC _N ¹	27	MCMC	Motor Command C	42	MCMD	Motor Command D
13	N/C	No Connect	28	RES	Reserved / MCMDD _N ¹	43	GND	Digital Ground
14	N/C	No Connect	29	N/C	No Connect	44	N/C	No Connect
15	+5V	+5V	30	N/C	No Connect			

Notes:

- 1 Negative differential motor command outputs when (DIFF) option is ordered on ICM. Ex *DMC-4040-C012-1000(DIFF)*. These pins may be used for other functions when (DIFF) option is not ordered.
- 2 Negative differential step and direction outputs when (STEP) option is ordered on ICM. EX *DMC-4040-C012-1000(STEP)*. These pins may be used for other functions when (STEP) option is not ordered.

ICM-42000 External Driver (E-H) 44 pin HD D-Sub Connector (Male)

4080

For DMC-4050 thru DMC-4080 controllers only.

Pin#	Label	Description	Pin#	Label	Description	Pin#	Label	Description
1	RES	Reserved / Step E_N ²	16	STPE	PWM / Step E	31	STPF	PWM / Step F
2	STPG	PWM / Step G	17	RES	Reserved / Step F_N ²	32	RES	Reserved / Step G_N ²
3	RES	Reserved / Step H_N ²	18	STPH	PWM / Step H	33	GND	Digital Ground
4	RES	Reserved / Dir E_N ²	19	DIRE	Sign / Direction E	34	DIRF	Sign / Direction F
5	DIRF	Sign / Direction F	20	RES	Reserved Dir F_N ²	35	RES	Reserved / Dir G_N ²
6	RES	Reserved / Dir H_N ²	21	DIRH	Sign / Direction H	36	GND	Digital Ground
7	AENE	Amplifier Enable E	22	AEC1	Amp Enable Common 1	37	AENF	Amplifier Enable F
8	AENH	Amplifier Enable H	23	AENG	Amplifier Enable G	38	AEC2	Amp Enable Common 2
9	N/C	No Connect	24	N/C	No Connect	39	GND	Digital Ground
10	-12V	-12V	25	+12V	+12V	40	MCME	Motor Command E
11	MCMF	Motor Command F	26	RES	Reserved / MCMDE_N ¹	41	RES	Reserved / MCMDF_N ¹
12	RES	Reserved / MCMDG_N ¹	27	MCMG	Motor Command G	42	MCMH	Motor Command H
13	N/C	No Connect	28	RES	Reserved / MCMDH_N ¹	43	GND	Digital Ground
14	N/C	No Connect	29	N/C	No Connect	44	N/C	No Connect
15	+5V	+5V	30	N/C	No Connect			

Notes:

- 1 Negative differential motor command outputs when (DIFF) option is ordered on ICM. Ex *DMC-4080-C012-1000-1000(DIFF)*. These pins may be used for other functions when (DIFF) option is not ordered.
- 2 Negative differential step and direction outputs when (STEP) option is ordered on ICM. EX *DMC-4080-C012-1000-1000(STEP)*. These pins may be used for other functions when (STEP) option is not ordered.

ICM-42000 Encoder 15 pin HD D-Sub Connector (Female)

Pin #	Label	Description
1	MI+	I+ Index Pulse Input
2	MB+	B+ Main Encoder Input
3	MA+	A+ Main Encoder Input
4	AB+	B+ Aux Encoder Input
5	GND	Digital Ground
6	MI-	I- Index Pulse Input
7	MB-	B- Main Encoder Input
8	MA-	A- Main Encoder Input
9	AA-	A- Aux Encoder Input
10	HALA	A Channel Hall Sensor
11	AA+	A+ Aux Encoder Input
12	AB-	B- Aux Encoder Input
13	HALB	B Channel Hall Sensor
14	HALC	C Channel Hall Sensor
15	+5V	+5V

ICM-42000 Analog 15 pin D-sub Connector (Male)

Pin #	Label	Description
1	AGND	Analog Ground
2	A11	Analog Input 1
3	A13	Analog Input 3
4	A15	Analog Input 5
5	A17	Analog Input 7
6	AGND	Analog Ground
7	-12V	-12V
8	+5V	+5V
9	AGND	Analog Ground
10	A12	Analog Input 2
11	A14	Analog Input 4
12	A16	Analog Input 6
13	A18	Analog Input 8
14	N/C	No Connect
15	+12V	+12V

Jumper Description for ICM-42000

Jumper	Label	Function (If jumpered)
Amplifier Enable	GND	Connect AECOM1 or AECOM2 to Digital Ground
	+5V	Connect AECOM1 or AECOM2 to Controller +5V
	+12V	Connect AECOM1 or AECOM2 to Controller +12V
	AEC1	Connect AECOM1 to AEC1 pin on External Driver D-Sub
	AEC2	Connect AECOM2 to AEC2 pin on External Driver D-Sub

Note: See ICM-42000 and ICM-42100 Amplifier Enable Circuit in Chapter 3 and Configuring the Amplifier Enable Circuit in the Appendix for more information.

A7 – ICM-42100 (-I100)

Description

The ICM-42100 option resides inside the DMC-40x0 enclosure and accepts sinusoidal encoder signals instead of digital encoder signals as accepted by the ICM-42000. The ICM-42100 provides interpolation of up to four 1-volt differential sinusoidal encoders resulting in a higher position resolution. The AFn command selects sinusoidal interpolation where n specifies 2^n interpolation counts per encoder cycle (n=5 to 12). For example, if the encoder cycle is 40 microns, AF10 results in $2^{10}=1024$ counts per cycle, or a resolution of 39 nanometers per count. With the ICM-42100, the sinusoidal encoder inputs replace the main digital encoder inputs. The ICM-42100 provides a 15-pin D-sub connector for the encoders on each axis, a 15-pin D-sub for analog inputs, a 44-pin D-sub for I/O, and a 44-pin D-sub for the motor command signals. Two ICMs are required for 5- thru 8-axis controllers.

Note: Hardware Rev B of the the ICM-42100 supports the use of standard differential quadrature encoders for axes that will not be using the sinusoidal encoders. A standard ICM-42100 does not support the use of single ended quadrature encoders. Contact Galil if a single ended quadrature encoder is required when using the ICM-42100, or if you require encoder inputs with a Rev A ICM-42100

The ID command will indicate the hardware Rev of the ICM-42100 where Rev B will return Rev 1 and Rev A will return Rev 0. A typical response from ID with a ICM-42100 Rev B is shown below.

```
DMC4000
Connector J3= Communications Board CMB-41012 5.0 volt i/o rev 0
Connector J1= 42100 Sine rev 1
Connector P1= Servo Amplifier Board AMP-43040 500 watt rev 1
Connector P2= Servo Amplifier Board AMP-43040 500 watt rev 1
```

Connectors for ICM-42100 Interconnect Board

ICM-42100 I/O (A-D) 44 pin HD D-Sub Connector (Female)

Pin#	Label	Description	Pin#	Label	Description	Pin#	Label	Description
1	ERR	Error Output	16	RST	Reset Input	31	GND	Digital Ground
2	DI1	Digital Input 1 / A latch	17	INCOM	Input Common	32	DI2	Digital Input 2 / B latch
3	DI4	Digital Input 4 / D latch	18	DI3	Digital Input 3 / C latch	33	DI5	Digital Input 5
4	DI7	Digital Input 7	19	DI6	Digital Input 6	34	DI8	Digital Input 8
5	ELO	Electronic Lock Out	20	ABRT	Abort Input	35	GND	Digital Ground
6	LSCOM	Limit Switch Common	21	N/C	No Connect	36	FLSA	Forward Limit Switch A
7	HOMA	Home Switch A	22	RLSA	Reverse Limit Switch A	37	FLSB	Forward Limit Switch B
8	HOMB	Home Switch B	23	RLSB	Reverse Limit Switch B	38	FLSC	Forward Limit Switch C
9	HOMC	Home Switch C	24	RLSC	Reverse Limit Switch C	39	FLSD	Forward Limit Switch D
10	HOMD	Home Switch D	25	RLSD	Reverse Limit Switch D	40	GND	Digital Ground
11	OPWR	Output Power	26	N/C	No Connect	41	DO1	Digital Output 1
12	DO3	Digital Output 3	27	DO2	Digital Output 2	42	DO4	Digital Output 4
13	DO6	Digital Output 6	28	DO5	Digital Output 5	43	DO7	Digital Output 7
14	ORET	Output Return	29	DO8	Digital Output 8	44	CMP	Output Compare
15	+5V	+5V	30	+5V	+5V			

ICM-42100 I/O (E-H) 44 pin HD D-Sub Connector (Female)

4080

For DMC-4050 thru DMC-4080 controllers only.

Pin#	Label	Description	Pin#	Label	Description	Pin#	Label	Description
1	ERR	Error Output	16	RST	Reset Input	31	GND	Digital Ground
2	DI9	Digital Input 9 / E latch	17	INCOM	Input Common	32	DI10	Digital Input 10 / F latch
3	DI12	Digital Input 12 / H latch	18	DI11	Digital Input 11 / G latch	33	DI13	Digital Input 13
4	DI15	Digital Input 15	19	DI14	Digital Input 14	34	DI16	Digital Input 16
5	ELO	Electronic Lock Out	20	ABRT	Abort Input	35	GND	Digital Ground
6	LSCOM	Limit Switch Common	21	N/C	No Connect	36	FLSE	Forward Limit Switch E
7	HOME	Home Switch E	22	RLSE	Reverse Limit Switch E	37	FLSF	Forward Limit Switch F
8	HOMF	Home Switch F	23	RLSF	Reverse Limit Switch F	38	FLSG	Forward Limit Switch G
9	HOMG	Home Switch G	24	RLSG	Reverse Limit Switch G	39	FLSH	Forward Limit Switch H
10	HOMH	Home Switch H	25	RLSH	Reverse Limit Switch H	40	GND	Digital Ground
11	OPWR	Output Power	26	N/C	No Connect	41	DO9	Digital Output 9
12	DO11	Digital Output 11	27	DO10	Digital Output 10	42	DO12	Digital Output 12
13	DO14	Digital Output 14	28	DO13	Digital Output 13	43	DO15	Digital Output 15
14	ORET	Output Return	29	DO16	Digital Output 16	44	CMP	Output Compare
15	+5V	+5V	30	+5V	+5V			

ICM-42100 External Driver (A-D) 44 pin HD D-Sub Connector (Male)

Pin#	Label	Description	Pin#	Label	Description	Pin#	Label	Description
1	RES	Reserved / Step A_N ²	16	STPA	PWM / Step A	31	STPB	PWM / Step B
2	STPC	PWM / Step C	17	RES	Reserved / Step B_N ²	32	RES	Reserved / Step C_N ²
3	RES	Reserved / Step D_N ²	18	STPD	PWM / Step D	33	GND	Digital Ground
4	RES	Reserved / Dir A_N ²	19	DIRA	Sign / Direction A	34	DIRB	Sign / Direction B
5	DIRC	Sign / Direction C	20	RES	Reserved / Dir B_N ²	35	RES	Reserved / Dir C_N ²
6	RES	Reserved / Dir D_N ²	21	DIRD	Sign / Direction D	36	GND	Digital Ground
7	AENA	Amplifier Enable A	22	AEC1	Amp Enable Common 1	37	AENB	Amplifier Enable B
8	AEND	Amplifier Enable D	23	AENC	Amplifier Enable C	38	AEC2	Amp Enable Common 2
9	N/C	No Connect	24	N/C	No Connect	39	GND	Digital Ground
10	-12V	-12V	25	+12V	+12V	40	MCMA	Motor Command A
11	MCMB	Motor Command B	26	RES	Reserved / MCMDA_N ¹	41	RES	Reserved / MCMDB_N ¹
12	RES	Reserved / MCMDC_N ¹	27	MCMC	Motor Command C	42	MCMD	Motor Command D
13	N/C	No Connect	28	RES	Reserved / MCMDD_N ¹	43	GND	Digital Ground
14	N/C	No Connect	29	N/C	No Connect	44	N/C	No Connect
15	+5V	+5V	30	N/C	No Connect			

Notes:

- 1 Negative differential motor command outputs when (DIFF) option is ordered on ICM. Ex *DMC-4040-C012-I100(DIFF)*.
These pins may be used for other functions when (DIFF) option is not ordered.
- 2 Negative differential step and direction outputs when (STEP) option is ordered on ICM. EX *DMC-4040-C012-I100(STEP)*.
These pins may be used for other functions when (STEP) option is not ordered.

ICM-42100 External Driver (E-H) 44 pin HD D-Sub Connector (Male)

4080

For DMC-4050 thru DMC-4080 controllers only.

Pin#	Label	Description	Pin#	Label	Description	Pin#	Label	Description
1	RES	Reserved / Step E_N ²	16	STPE	PWM / Step E	31	STPF	PWM / Step F
2	STPG	PWM / Step G	17	RES	Reserved / Step F_N ²	32	RES	Reserved / Step G_N ²
3	RES	Reserved / Step H_N ²	18	STPH	PWM / Step H	33	GND	Digital Ground
4	RES	Reserved / Dir E_N ²	19	DIRE	Sign / Direction E	34	DIRF	Sign / Direction F
5	DIRF	Sign / Direction F	20	RES	Reserved / Dir F_N ²	35	RES	Reserved / Dir G_N ²
6	RES	Reserved / Dir H_N ²	21	DIRH	Sign / Direction H	36	GND	Digital Ground
7	AENE	Amplifier Enable E	22	AEC1	Amp Enable Common 1	37	AENF	Amplifier Enable F
8	AENH	Amplifier Enable H	23	AENG	Amplifier Enable G	38	AEC2	Amp Enable Common 2
9	N/C	No Connect	24	N/C	No Connect	39	GND	Digital Ground
10	-12V	-12V	25	+12V	+12V	40	MCME	Motor Command E
11	MCMF	Motor Command F	26	RES	Reserved / MCMDE_N ¹	41	RES	Reserved / MCMDF_N ¹
12	RES	Reserved / MCMDG_N ¹	27	MCMG	Motor Command G	42	MCMH	Motor Command H
13	N/C	No Connect	28	RES	Reserved / MCMDH_N ¹	43	GND	Digital Ground
14	N/C	No Connect	29	N/C	No Connect	44	N/C	No Connect
15	+5V	+5V	30	N/C	No Connect			

Notes:

- 1 Negative differential motor command outputs when (DIFF) option is ordered on ICM. Ex *DMC-4080-C012-I100-I100(DIFF)*. These pins may be used for other functions when (DIFF) option is not ordered.
- 2 Negative differential step and direction outputs when (STEP) option is ordered on ICM. EX *DMC-4080-C012--I100-I100(STEP)*. These pins may be used for other functions when (STEP) option is not ordered.

ICM-42100 Encoder 15 pin HD D-Sub Connector (Female)

Pin #	Label	Description
1	MI+	Index Pulse Input - V_{0+} (Sin/Cos) or I+ (Digital)
2	MB+	Main Encoder Input - V_{2+} (Sin/Cos) or B+ (Digital)
3	MA+	Main Encoder Input - V_{1+} (Sin/Cos) or A+ (Digital)
4	AB+	Aux Encoder Input- B+ (Digital)
5	GND	Digital Ground
6	MI-	Index Pulse Input- V_{0-} (Sin/Cos) or I- (Digital)
7	MB-	Main Encoder Input- V_{2-} (Sin/Cos) or B- (Digital)
8	MA-	Main Encoder Input- V_{1-} (Sin/Cos) or A- (Digital)
9	AA-	Aux Encoder Input- A- (Digital)
10	HALA	A Channel Hall Sensor
11	AA+	Aux Encoder Input- A+ (Digital)
12	AB-	Aux Encoder Input- B- (Digital)
13	HALB	B Channel Hall Sensor
14	HALC	C Channel Hall Sensor
15	+5V	+5V

ICM-42100 Analog 15 pin D-sub Connector (Male)

Pin #	Label	Description
1	AGND	Analog Ground
2	A11	Analog Input 1
3	A13	Analog Input 3
4	A15	Analog Input 5
5	A17	Analog Input 7
6	AGND	Analog Ground
7	-12V	-12V
8	+5V	+5V
9	AGND	Analog Ground
10	A12	Analog Input 2
11	A14	Analog Input 4
12	A16	Analog Input 6
13	A18	Analog Input 8
14	N/C	No Connect
15	+12V	+12V

Theory of Operation

Traditional quadrature rotary encoders work by having two sets of lines inscribed radially around the circumference of an optical disk. A light is passed through each of these two sets of lines. On the other side of the gratings, photo sensors detect the presence (or absence) of these lines. These two sets of lines are offset from each other such that one leads the other by one quarter of a complete cycle as shown in Figure 3 below. These signals are commonly referred to as the Channels A and B. The direction of rotation of the encoder can be inferred by which of the A and B signals leads the other. Each rising or falling edge indicates one quadrature count. Thus for a complete cycle of the square wave there are a total of four encoder counts.

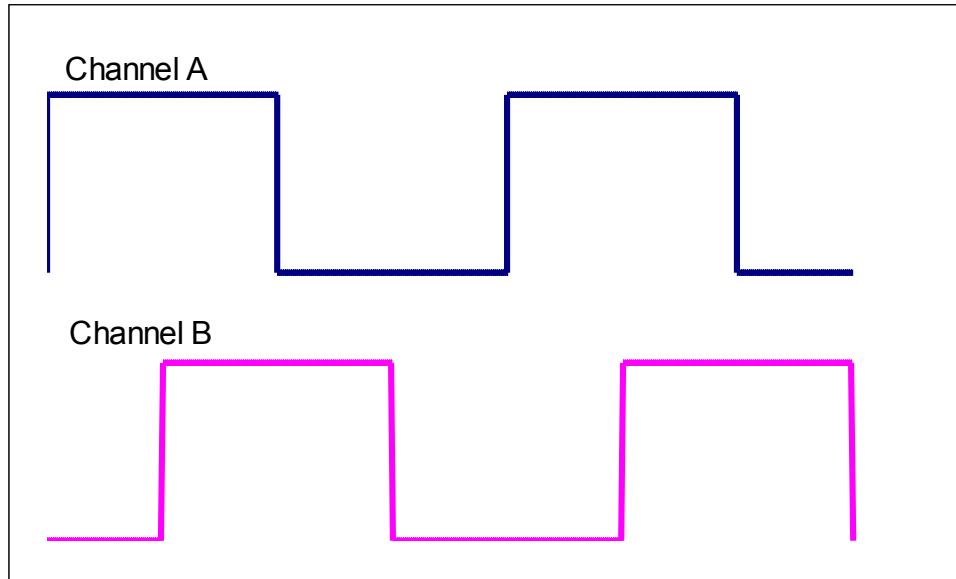

Figure A7-22: Quadrature Encoder Signals

A sinusoidal encoder is similar to a quadrature encoder in that it produces two signals that are read from two sets of lines inscribed on an optical disk. The difference is that the two signals are output as analog sinusoidal waves as shown in Figure A7-23: Sinusoidal Encoder Signals.

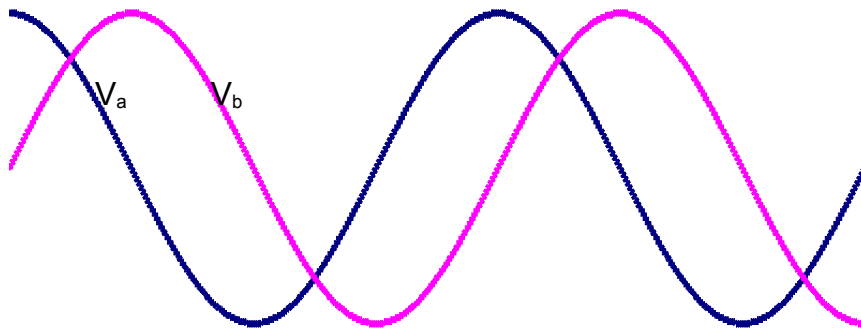

Figure A7-23: Sinusoidal Encoder Signals

When the DMC-40x0 is ordered with the ICM-42100, the position is tracked on two levels. First, the number of coarse cycles is counted much like is done with a quadrature encoder. On the fine level the precise position inside the cycle is determined from the two sinusoidal signals using bit-wise interpolation. This interpolation can be set by

the user in the range of 2^5 through 2^{12} points per sinusoidal cycle via AF command. See the AF command in the command reference for more information.

The unique position within one cycle can be read using the following equation:

$$\text{Fine} = \frac{2^n}{360} \tan^{-1} \left(\frac{V_b}{V_a} \right)$$

The overall position can be determined using:

$$\text{Position} = \text{Coarse_cycles} \cdot 2^n + \text{Fine}$$

Where:

n is the number of bits of resolution that were used in the conversion.

Coarse_cycles is the whole number of cycles counted.

Fine is the interpolated position within one cycle.

Vb and Va are the two signals as indicated in Figure A7-23: Sinusoidal Encoder Signals.

For example, if the encoder cycle is 40 microns, AF10 results in $2^{10}=1024$ counts per cycle, or a resolution of 39 nanometers per count.

A8 – ICM-42200 (-I200)

Description

The ICM-42200 interconnect option resides inside the DMC-40x0 enclosure and provides a pin-out that is optimized for easy connection to external drives. The ICM-42200 uses 26-pin HD D-sub connectors for each axis that includes encoder, limit, home, and motor command signals. Other connectors include a 44-pin HD D-sub for digital I/O, and a 15-pin LD D-sub for analog I/O. The ICM-42200 is configurable on each individual axis for high or low amplifier enable; 5 V, 12 V or isolated input power (up to 24 V); sinking or sourcing. The DMC-40x0 cover does not have to be removed to install these options. Two ICMs are required for 5- through 8-axis controllers.

Connectors for ICM-42200 Interconnect Board

ICM-42200 I/O (A-D) 44 pin HD D-Sub Connector (Female)

Pin#	Label	Description	Pin#	Label	Description	Pin#	Label	Description
1	ERR	Error Output	16	RST	Reset Input	31	GND	Digital Ground
2	DI1	Digital Input 1/ A latch	17	INCOM	Input Common	32	DI2	Digital Input 2 / B latch
3	DI4	Digital Input 4 / D latch	18	DI3	Digital Input 3 / C latch	33	DI5	Digital Input 5
4	DI7	Digital Input 7	19	DI6	Digital Input 6	34	DI8	Digital Input 8
5	ELO	Electronic Lock Out	20	ABRT	Abort Input	35	GND	Digital Ground
6	LSCOM	Limit Switch Common	21	N/C	No Connect	36	FLSA	Forward Limit Switch A
7	HOMA	Home Switch A	22	RLSA	Reverse Limit Switch A	37	FLSB	Forward Limit Switch B
8	HOMB	Home Switch B	23	RLSB	Reverse Limit Switch B	38	FLSC	Forward Limit Switch C
9	HOMC	Home Switch C	24	RLSC	Reverse Limit Switch C	39	FLSD	Forward Limit Switch D
10	HOMD	Home Switch D	25	RLSD	Reverse Limit Switch D	40	GND	Digital Ground
11	OPWR	Output Power	26	N/C	No Connect	41	DO1	Digital Output 1
12	DO3	Digital Output 3	27	DO2	Digital Output 2	42	DO4	Digital Output 4
13	DO6	Digital Output 6	28	DO5	Digital Output 5	43	DO7	Digital Output 7
14	ORET	Output Return	29	DO8	Digital Output 8	44	CMP	Output Compare
15	+5V	+5V	30	+5V	+5V			

ICM-42200 DMC-40x0 I/O (E-H) 44 pin HD D-Sub Connector (Female)

4080

For DMC-4050 thru DMC-4080 controllers only.

Pin#	Label	Description	Pin#	Label	Description	Pin#	Label	Description
1	ERR	Error Output	16	RST	Reset Input	31	GND	Digital Ground
2	DI9	Digital Input 9 / E latch	17	INCOM	Input Common	32	DI10	Digital Input 10 / F latch
3	DI12	Digital Input 12/H latch	18	DI11	Digital Input 11 / G latch	33	DI13	Digital Input 13
4	DI15	Digital Input 15	19	DI14	Digital Input 14	34	DI16	Digital Input 16
5	ELO	Electronic Lock Out	20	ABRT	Abort Input	35	GND	Digital Ground
6	LSCOM	Limit Switch Common	21	N/C	No Connect	36	FLSE	Forward Limit Switch E
7	HOME	Home Switch E	22	RLSE	Reverse Limit Switch E	37	FLSF	Forward Limit Switch F
8	HOMF	Home Switch F	23	RLSF	Reverse Limit Switch F	38	FLSG	Forward Limit Switch G
9	HOMG	Home Switch G	24	RLSG	Reverse Limit Switch G	39	FLSH	Forward Limit Switch H
10	HOMH	Home Switch H	25	RLSH	Reverse Limit Switch H	40	GND	Digital Ground
11	OPWR	Output Power	26	N/C	No Connect	41	DO9	Digital Output 9
12	DO11	Digital Output 11	27	DO10	Digital Output 10	42	DO12	Digital Output 12
13	DO14	Digital Output 14	28	DO13	Digital Output 13	43	DO15	Digital Output 15
14	ORET	Output Return	29	DO16	Digital Output 16	44	CMP	Output Compare
15	+5V	+5V	30	+5V	+5V			

ICM-42200 Encoder 26 pin HD D-Sub Connector (Female)

Pin #	Label	Description	Pin #	Label	Description
1	RES	Reserved / Hall 2 ¹	14	FLS	Forward Limit Switch Input
2	AEN	Amplifier Enable	15	AB+	B+ Aux Encoder Input
3	DIR	Direction	16	MI-	I- Index Pulse Input
4	HOM	Home	17	MB+	B+ Main Encoder Input
5	LSCOM	Limit Switch Common	18	GND	Digital Ground
6	AA-	A- Aux Encoder Input	19	MCMD	Motor Command
7	MI+	I+ Index Pulse Input	20	ENBL+	Amp Enable Power
8	MA-	A- Main Encoder Input	21	RES	Reserved / Hall 0 / Step_N ³
9	+5V	+5V	22	RLS	Reverse Limit Switch Input
10	GND	Digital Ground	23	AB-	B- Aux Encoder Input
11	ENBL-	Amp Enable Return	24	AA+	A+ Aux Encoder Input
12	RES	Reserved / Hall 1/ Dir_N ²	25	MB-	B- Main Encoder Input
13	STP	PWM/Step	26	MA+	A+ Main Encoder Input

Notes:

- Negative differential motor command output when (DIFF) option is ordered on ICM. Ex *DMC-4040-C012-I200(DIFF)*.
Hall Input 2 when ordered with internal amplifier AMP-43040. Ex *DMC-4040-C012-I200-D3040*
Connected to GND in standard configuration.
- Hall Input 1 when ordered with internal amplifier AMP-43040. Ex *DMC-4040-C012-I200-D3040*
Negative differential direction output when (STEP) option is ordered on ICM. Ex *DMC-4040-C012-I200(STEP)*
Connected to GND in standard configuration.
- Hall Input 0 when ordered with internal amplifier AMP-43040. Ex *DMC-4040-C012-I200-D3040*
Negative differential step output when (STEP) option is ordered on ICM. Ex *DMC-4040-C012-I200(STEP)*
Connected to GND in standard configuration.

ICM-42200 Analog 15 pin D-sub Connector (Male)

Pin #	Label	Description
1	AGND	Analog Ground
2	AI1	Analog Input 1
3	AI3	Analog Input 3
4	AI5	Analog Input 5
5	AI7	Analog Input 7
6	AGND	Analog Ground
7	-12V	-12V
8	+5V	+5V
9	AGND	Analog Ground
10	AI2	Analog Input 2
11	AI4	Analog Input 4
12	AI6	Analog Input 6
13	AI8	Analog Input 8
14	N/C	No Connect
15	+12V	+12V

Jumper Description for ICM-42200

Jumper	Label	Function (If jumpered)
Q and P	1	Sink/Source Selection
	2	Sink/Source Selection
	3	Sink/Source Selection
	4	HAEN/LAEN Selection
	5	5V/12V/External Power Selection
	6	5V/12V/External Power Selection

Note: See ICM-42200 Amplifier Enable Circuit in Chapter 3 for detailed information.

Index

Abort.....	86, 92, 179, 181, 210
Absolute Position.....	26, 78, 136, 141
Absolute Value.....	100, 141, 153, 180
Acceleration.....	2, 24, 138, 160, 166, 228
Address.....	157
Amplifier Enable.....	179
Amplifier Gain.....	3, 189, 193, 195
Analog Input.....	1, 4, 32, 39, 81, 154, 156, 176, 199, 230
Arithmetic Functions.....	140, 152
Arm Latch.....	128
Array.....	1, 4, 14, 77, 90, 111, 134, 140, 152, 156, 201
Automatic Subroutine.....	143
TCPERR.....	147
Auxiliary Encoder.....	98
Backlash.....	77, 120, 176
Baud Rate.....	16, 49
Begin Motion.....	20, 23, 137, 144, 155, 159
Binary.....	1, 53, 70, 73, 171
Bit-Wise.....	152
Burn 22, 48	
Burn	
EEPROM.....	1
Bypassing Optoisolation.....	37
Circle.....	173
Circular Interpolation.....	91, 96, 158, 173
Clear Bit.....	167, 210
Clear Sequence.....	86, 88, 92, 94
Clock.....	156
CMDERR.....	132, 143, 145
Code 144, 158, 172, 175	
Command Summary.....	78, 80, 88, 94, 158
Commanded Position.....	79, 95, 145, 158, 185
Conditional jump.....	34, 135, 138
Contour Mode.....	76, 110
Coordinated Motion.....	76, 91
Cosine.....	77, 152, 157
DAC 188, 191, 195	
Damping.....	188
Data Capture.....	157
Data Record.....	55, 60, 61
Debugging.....	134

Deceleration.....	160
Digital Filter.....	192, 195
Digital Input.....	34, 153
Digital Output.....	153
Dual Encoder.....	121, 158
Dual Loop.....	77, 114, 115, 120, 176
Ecaml.....	100, 103
Echo 49, 62	
Edit Mode.....	28, 144
Editor.....	28
EEPROM.....	4, 14, 171, 257
Electronic Cam.....	76, 99
Ellipse Scale.....	94
Encoder.....	
Auxiliary Encoder.....	1, 5, 19, 24, 37, 168, 200, 211
Differential.....	6, 19, 21, 37, 168, 199, 200
Dual Encoder.....	75
Error Code.....	53, 74, 156
Error Handling.....	ii
Error Limit.....	144, 179
Error Limit.....	
Off-On-Error.....	18, 41
Example.....	
Communication Interrupt.....	146, 161
Design Example.....	25
Ethernet Communication Error.....	147
Input Interrupt.....	169
Opto 22.....	230
Output Bit.....	167
Output Port.....	167
Printing a Variable.....	164
Set Bit and Clear Bit.....	167
Sinusoidal Commutation.....	17, 21
Start Motion on Switch.....	168
Turn on output after move.....	167
Using Inputs.....	168
Feedrate.....	88, 92, 94, 138, 173
FIFO.....	62, 134
Filter Parameter.....	
Gain.....	25
Proportional.....	24, 25
Find Edge.....	33
Formatting.....	163, 165, 166
Frequency.....	24, 124, 194, 199
Function.....	86, 111, 121, 138, 140, 144, 174, 176
Function.....	
Arithmetic.....	130, 166
Gain 3, 5, 20, 24, 25, 28, 155	
Gear Ratio.....	95
Gearing.....	1, 76, 95
Halt 87, 138	
Hardware.....	32
I/O 167	
Hardware Handshake.....	49, 62
Home Input.....	33, 156
Home Inputs.....	124

Homing.....	33
I/O	
Amplifier Enable.....	19
Digital Input.....	1, 168
Home Input.....	199
Limit Switch.....	211
Index Pulse.....	19, 33
ININT.....	132, 143
Input Interrupt.....	132, 144, 168, 169
Input of Data.....	159
Installation.....	183
Integrator.....	24, 25, 188
Internal Variable.....	140, 154, 155
Interrogation.....	24, 26, 27, 74, 75, 89, 95, 164, 165
Interrupt.....	138, 143
Invert.....	20, 120
Jog 1, 80, 95, 104, 128, 137, 144, 155, 161, 176, 181	
Joystick.....	81, 155, 175
Jumper.....	13, 14, 184, 257, 262, 272
Keyword.....	140, 152, 154, 156
Label.....	24, 81, 91, 102, 113, 122, 128, 136, 155, 160, 174, 176, 181
Limit Switch.....	143, 156, 180
LIMSWI.....	32, 132, 143, 180
Linear Interpolation.....	76, 86, 96, 110
Logical Operator.....	140, 160
Masking.....	
Bit-Wise.....	162
Mathematical Expression.....	152, 154
MCTIME.....	132, 136, 143, 145
Memory.....	1, 2, 21, 22, 28, 70, 112, 130, 134, 140, 144, 156, 157, 171
Message.....	49, 52, 62, 91, 134, 144, 153, 159, 162, 163, 181
Modbus.....	52, 53, 54, 55, 231
Modelling.....	185, 188, 193
Motion Smoothing.....	124
Motor Command.....	22, 193
Multitasking.....	133
Off-On-Error.....	33, 179, 181
Output.....	
Amplifier Enable.....	6, 18, 41
Digital Output.....	1, 167
Error Output.....	39
Motor Command.....	2, 17, 20, 21, 22, 210
Step and Direction.....	2
PID 188, 197	
Play Back.....	77, 159
POSERR.....	132, 143, 180
Position Capture.....	127
Position Error.....	121, 132, 143, 155, 158, 177, 179, 187
Position Limit.....	181
Program Flow.....	131, 135, 168
Interrupt.....	1, 146, 147, 161, 168
Programmable.....	154, 176, 180
Programming.....	70, 76
Proportional Gain.....	24, 188
Protection.....	
Error Limit.....	18, 20, 25, 39, 41

PWM.....	5, 210
Quadrature.....	4, 6, 120, 166, 172, 180, 191, 199
Quit	
Abort.....	1, 199, 211
Record.....	77, 111, 156, 159
Register.....	15, 16, 155
Reset.....	2, 14, 19, 22, 23, 32, 39, 52, 62, 139, 179, 181, 211, 257
S-Curve.....	87, 123
SDK 130	
Serial Port.....	16, 17, 146, 147, 161, 163, 208, 209
Set Bit.....	167, 210
Sine 77, 102, 153	
Single-Ended.....	6, 19, 21, 199
Slew 24, 25, 78, 98, 136, 138, 172	
Smoothing.....	1, 24, 77, 87, 88, 92, 94, 122
Special Label.....	132, 182
Specification.....	87, 92
Stability.....	121, 176, 183, 188, 194
Stack.....	142, 145, 147
Status.....	158
Step Motor.....	2, 3, 5, 13, 24, 124
Step Motor.....	
KS, Smoothing.....	24
Stepper Position Maintenance.....	117
Stop Code.....	75, 158
Stop Motion.....	86, 92, 145, 182
Subroutine.....	32, 91, 130, 132, 139, 161, 168, 180
Synchronization.....	1, 6, 48, 99
Syntax.....	70, 71
Tangent.....	77, 91, 93
Teach.....	113
Teach	
Latch.....	5, 75
Tell Error Code.....	74, 75
Tell Position.....	26, 62, 75, 165
Tell Torque.....	21, 75
Terminal.....	14, 15, 16, 17, 20, 28, 32, 70, 155
Theory.....	185
Theory	
Damping.....	24
Digital Filter.....	70
PID.....	2, 21, 24, 25
TIME.....	156
Time Interval.....	110, 113, 158
Timeout.....	16, 132, 136, 143, 145
Torque Limit.....	20, 27
Trigger.....	130, 135, 137, 187, 210
Trippoint.....	29, 78, 87, 93, 136, 142, 143
Troubleshoot.....	183
TTL 4, 32, 37, 39, 41, 179, 199, 210	
Tuning.....	1, 12, 21, 25
Tuning	
WSDK.....	16
Upload.....	28
User Unit.....	166
Variable.....	14, 29, 75, 130, 162, 163, 164, 166

Variable.....	
Internal Variable.....	30
Vector Acceleration.....	30, 88, 94, 174
Vector Deceleration.....	30, 88, 94
Vector Mode.....	
Circular Interpolation.....	30
Linear Interpolation.....	30
Vector Speed.....	30, 86, 94, 138, 174
Wire Cutter.....	172
Zero Stack.....	145, 169